

# COUNTY OF SACRAMENTO DEPARTMENT OF PUBLIC WORKS

## Improvement Standards

Adopted by the Board of Supervisors, October 3, 1966



**A. L. KIEFER** Director  
Department of Public Works

C O U N T Y   O F   S A C R A M E N T O

D E P A R T M E N T   O F   P U B L I C   W O R K S

I M P R O V E M E N T   S T A N D A R D S

RESOLUTION NO. 66-1048

WHEREAS, the Board of Supervisors deems it necessary and advisable in the public interest to revise existing improvement standards governing the design of roads, streets, sanitary sewers, storm drainage, concrete structures, water supply, street lighting, and other facilities within the County of Sacramento, to provide for proper development;

NOW, THEREFORE, BE IT RESOLVED AND ORDERED that the attached Improvement Standards and Standard Drawings for said improvements are hereby adopted as the Sacramento County, Department of Public Works Improvement Standards; and

BE IT FURTHER RESOLVED AND ORDERED that the Improvement Standards adopted pursuant to Resolution 23022, as amended, are hereby repealed; and

BE IT FURTHER RESOLVED AND ORDERED that the Improvement Standards adopted herein, together with the Standard Specifications and Standard Drawings adopted pursuant to Resolution 65-627, shall govern the design and construction of improvements in Sacramento County; and

BE IT FURTHER RESOLVED AND ORDERED that this resolution shall be in full force and effect on and after November 1, 1966.

PASSED AND ADOPTED by the Board of Supervisors of the County of Sacramento, State of California, this 3rd day of October, 1966, by the following vote, to-wit:

AYES: Supervisors , Barbaria, Kloss, Phelan, Wood, Gualco

NOES: Supervisors , None

ABSENT: Supervisors , None

(SEAL)

ATTEST:

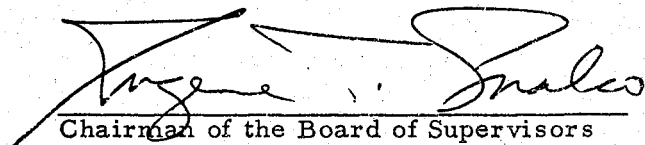
  
Chairman of the Board of Supervisors

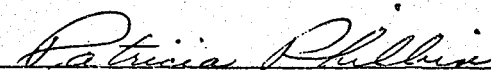
  
Asst. Clerk of the Board of Supervisors

# I N D E X

	<u>Section</u>	<u>Page</u>
GENERAL		
Alley - Defined	9.01	9
As Built Plans	8.00	9
Barricades, Permanent	15.02	18
Barrier Curb	9.14	12
Class "A" Street	9.10	10
Class "B" Street	9.11	11
Class "C" Street	9.12	11
Consulting Engineer - Defined	2.01-1	1
Contractor - Defined	2.01-2	1
County - Defined	2.01-3	2
Cross Gutters	11.03	13
Cross Slope	11.02	13
Gul-de-sacs	11.05	13
Curve Radius, Minimum	11.04	13
Definitions	2.00	1
Department of Public Works - Defined	2.01-4	2
Director - Defined	2.01-5	2
Driveways	11.06	14
Engineer - Defined	2.01-6	2
Frontage Improvements	9.13	11
Grades	10.02	12
Improvement Plans, Additional Copies	3.05	4
Approval	3.03	3
Details	5.00	5
General Requirements	3.01	2
Title Sheet	5.02-1	5
Title Blocks	5.02-2	6
Right of Way	5.02-3	6
Topography	5.02-4	6
Profiles	5.02-5	6
Stationing	5.02-6	7
Bench Marks	5.02-7	7
California Coordinate System	5.02-8	7
Typical Sections	5.02-9	7
Cross Sections	5.02-10	7

	<u>Section</u>	<u>Page</u>
Inspection	6.00	8
Inspection, Final	7.00	8
Laboratory - Defined	2.01-7	2
Partial Street	11.08	14
Partial Street - Defined	9.09	10
Pedestrian Walk	11.07	14
Purpose	1.00	1
Right of Way	14.00	17
Standard Sheets	4.00	5
Standard Specifications - Defined	2.01-8	2
Standard Specifications, Part of Contract	3.02	3
State - Defined	2.01-10	2
State Specifications - Defined	2.01-9	2
State Standard Drawings - Defined	2.01-11	2
Street Names	15.01	17
Street Name Signs	15.01	17
Structure Section	11.09	15
Survey Monuments	12.00	15
Testing of Materials	13.00	17
Type "F" Street - Defined	9.08	10
Type "I" Street - Defined	9.07	10
Utilities, Shown on Improvement Plans	3.04 & 3.08	4
Work Order, Contractor	5.02-12	7
Zoning Classifications - Defined	2.01-12	2
42 Foot Street - Defined	9.02	9
54 Foot Street - Defined	9.03	9
60 Foot Street - Defined	9.04	9
80 Foot Street - Defined	9.05	10
100 Foot Street - Defined	9.06	10
110 Foot Street - Defined	9.06	10

#### DRAINAGE

Alignment	17.02	19
Asbestos Cement Pipe	20.05	23
Capacity	17.01	19
Closed Conduits	20.03	23
Collector - Defined	16.01-2	19
Conductor Pipe	21.11	30
Corrugated Metal Pipe	20.04	23
Cross Culverts	23.01	32

	<u>Section</u>	<u>Page</u>
Design Criteria	20.00	22
Design Runoff	19.00	21
Drainage Pump	21.09	29
Drainage Wells	21.08	28
Easements	18.00	20
Fencing	24.00	33
Headwalls	21.07	28
Inlets	21.03	26
Junction Boxes	21.04	27
Lateral - Defined	16.01-1	19
Location	17.03	19
Manholes	21.02	25
"N" Values	20.02-3	22
Open Channels	22.02	31
Open Conduits	20.07	24
Outfalls	22.03	32
Temporary Drainage	21.10	30
Trunk - Defined	16.01-3	19
Wye Connections	21.05	27

#### STREET LIGHTING

Backfill	37.00	40
Ballasts	30.00	36
Bonding	41.00	42
Cable	33.00	37
Clean-up	38.00	41
Concrete	35.00	38
Conductors	33.00	37
Conduit	36.00	38
Control Equipment	32.00	37
Design Standard	25.01	34
Excavation	37.00	40
Grounding	41.00	42
Lamps	29.00	36
Lighting Standard	27.00	35
Luminaires	28.00	36
Materials	26.00	34
Paint	34.00	38
Pavement Replacement	38.00	41

	<u>Section</u>	<u>Page</u>
Power Service	42.00	43
Public Convenience	38.00	41
Pullboxes	31.00	36
Standard Bases	39.00	41
Standards	39.00	41
Wiring	40.00	41

### SANITARY SEWERS

Alignment	47.00	45
Boring	54.00	51
Cover Sheet	57.05	53
Creek Crossing, Above	53.03	51
Below	53.02	50
Detail Sheet	57.08	57
Drop Connections	50.00	48
Flow Design	45.00	44
Flow, Determination	44.00	44
Flushing Branches	51.00	48
Force Mains	56.00	51
General Notes	57.09	57
Jacking	54.00	51
Layout Sheet	57.06	54
Location	47.00	45
Manholes	49.00	47
Pipe Size, Minimum	46.01	45
Plan Sheet	57.07	54
Preliminary Plans	57.02	52
Pump Stations	56.00	51
Service Sewers	52.00	48
Service Sewers, Depth	52.05	49
Size	52.02	49
Taps	52.03	49
Trench Loading	48.00	46
Velocity, Minimum Pipe	46.02	45

	<u>Section</u>	<u>Page</u>
DOMESTIC WATER		
Blow-off	60.03	62
Design Criteria	58.03	58
Fire Flow	59.04	59
Flow Rates	59.03	59
Hydrants	60.03	62
Location	60.01	61
Pressure	59.02	59
Pumping Plant Design	59.05	60
Purpose	58.02	58
Service Lines	60.04	63
Service Taps	60.04-3	64
Size	59.06	60
Valves	60.03	62
Wall Design	59.05	60

Identification List - Electrical Drawings 65-71



## 1.00 PURPOSE:

1.01 It is the purpose of these Improvement Standards to provide minimum standards to be applied to improvements and private works to be dedicated to the public and accepted by the County for maintenance or operation. This is necessary in order to provide for coordinated development of required facilities to be used by and for the protection of the public. These Standards shall apply to and regulate the design and preparation of plans for construction of streets, highways, alleys, drainage, sewerage, street lighting, water supply facilities and related public improvements.

1.02 It is recognized that it is not humanly possible to anticipate all situations that may arise or to prescribe standards applicable to every situation. Therefore, any items or situation not included in this Manual shall be designed in accordance with accepted engineering practice, the Sacramento County Standard Specifications, and as specified by the Director of Public Works.

## 2.00 DEFINITIONS:

2.01 In this Manual, the intent and meaning of the terms that are used shall be as defined in County Standard Specifications, and as herein specifically noted.

2.01-1 Consulting Engineer - Any person or persons, firms, partnership or corporation legally authorized to practice civil engineering in the State of California who prepares or submits improvement plans and specifications to the Department of Public Works of Sacramento County for approval.

2.01-2 Contractor - Shall mean any person or persons, firm, partnership, corporation, or combination thereof, licensed to perform the type of work involved, who has entered into a contract with any person, corporation, company, special district, of the County of Sacramento as party or parties of the second part, or his or their legal representatives, for the construction of any improvement or portions of any improvement within the County of Sacramento.

2.01-3 County - Shall mean County of Sacramento.

2.01-4 Department of Public Works - Shall mean the Department of Public Works of Sacramento County.

2.01-5 Director - Shall mean the Director of Public Works of Sacramento County acting either directly or through the Chiefs of the appropriate Division of the Department of Public Works or their authorized representatives.

2.01-6 Engineer - Meaning shall be identical to the definition of Director as herein defined.

2.01-7 Laboratory - Shall mean any testing agency or testing firm which has been approved by the Department of Public Works.

2.01-8 Standard Specifications - Shall mean the Sacramento County Standard Specifications adopted June 14, 1965, by the Board of Supervisors and amendments thereto.

2.01-9 State Specifications - Shall mean the Standard Specifications of the State of California, Department of Public Works, Division of Highways, dated July 1964.

2.01-10 State - As used in the State Specifications, shall mean Sacramento County.

2.01-11 State Standard Drawings - Shall mean the Standard Drawings and plans of the State of California, Department of Public Works, Division of Highways.

2.01-12 Zoning Classifications - Zones R-E-1 through M-2 refer to those established by and as listed in Sacramento County Basic Zoning Ordinance No. 534 and amendments thereto.

### 3.00 GENERAL REQUIREMENTS:

3.01 Complete plans and specifications for all proposed streets, drainage facilities, sewerage, street lighting, water distribution systems, industrial development and subdivision, including any necessary dedications and easements shall be submitted to the Department of Public Works for approval

and this approval must be substantiated by the signature of the Director prior to the beginning of construction of any such improvements. The County Construction Engineer or Inspector shall order the Contractor to cease work on any project if said Contractor does not have properly approved plans in his possession. Possession of County approved plans shall constitute the only necessary permit for a Contractor duly licensed by the State of California, to perform work of the type involved, in the County right of way. The Contractor shall be bonded as required under Ordinance No. 421.

3.02 The Standard Specifications shall be made a part of contract documents by note of reference which shall appear in the Special Provisions and in the General Notes of the plans. The note of reference shall be as follows: The Sacramento County Standard Specifications adopted June 14, 1965, are part of the contract documents of this project and all materials and construction shall be in strict conformance with said Standard Specifications.

3.03 Plans, complete and in accordance with these Improvement Standards and the Standard Specifications, shall be submitted in triplicate, including the required specifications, computations, test data, and other material requested by the Director, to the Department of Public Works for approval. Should there be required alterations or revisions to the plans as submitted, the Director will return one copy with the required corrections marked or indicated thereon. If the plans submitted are not prepared in accordance with these Improvement Standards and the Standard Specifications or not in keeping with the standards of the profession, the Director may return them unmarked and unapproved. No plans will be approved or construction authorized until such time as the Director signifies his approval by his signature on the set of plans and not unless such changes, corrections or additions are resubmitted to the Director for approval as previously prescribed for the original plans. At such time as the Consulting Engineer preparing the plans has made the necessary revisions, the plan check and inspection fee, as provided under the provisions of Ordinance No. 775, July 1962, and amendments thereto, and any fee required under the provisions of Drainage Ordinance No. 1, and amendments thereto, have been paid, the Director will sign the tracings in the space provided. The Consulting Engineer shall deliver the necessary sets of prints from the approved tracings to the Director.

Should changes become necessary during construction, the Consulting Engineer must obtain the consent of the Director and resubmit the plan sheets that are applicable. Necessary changes shall be clearly shown and dated on the plans. Minor changes, which do not affect the basic design or contract may be made upon the authorization of the County Construction Engineer but said changes must be shown on "as built" plans when the contract is completed. Excepted from approval are any features of the plans that are contrary to, or conflict with, or do not conform to any California State Law, Sacramento County Ordinance or Resolution or generally accepted good engineering practice, in keeping with the standards of the profession; even though such errors, omissions or conflict may have been overlooked in the Department of Public Works review of the plans.

3.04 As required in Section 5.02-4, all utilities are to be shown on the plans. In addition, the Consulting Engineer must submit to the utility companies involved, prints of the approved plans. This is necessary for the utilities to properly plan their relocation projects and needed additional facilities. The Consulting Engineer shall notify the Director, by letter, when and which utility companies have been so notified.

3.05 Additional copies of improvement plans may be requested by the Director at his discretion, and these shall be furnished the County without cost.

3.06 Where the improvement plans submitted cover only a portion of ultimate development, the plans submitted must be accompanied by the approved tentative plan or a study plan if there is no approved tentative plan showing topographic features of the ultimate development at an adequate scale to clearly show the proposed improvements.

3.07 A print of the recorded subdivision shall be included with each set of subdivision improvement plans submitted. This may be incorporated in the title sheet as described in Section 5.02-1.

3.08 A print of the subdivision map showing the location of all proposed underground utilities and water lines, if the water service is supplied by a private company, must be submitted for the issuance of a separate encroachment permit.

#### 4.00 STANDARD SHEETS AND SCALES:

4.01 All improvement plans shall be prepared on plan and profile sheets 22" x 36", F.A.S. sheets, Plate "A" plan and profile paper, or special consulting engineer's sheets which have been accepted by the County. Scale: Horizontal 1" = 40' or 50'; Vertical 1" = 2', 4', or 5'.

Plans which are primarily for sanitary sewer projects shall preferably be prepared on special plan and profile sheets. Sheets shall be 22" x 36" and shall comply with the requirements of Section 57.00.

4.02 Storm drainage, sanitary sewer, street lighting, and water plans may be shown on the street plans or separately as indicated above. Where wells are included as a part of the water system, the layout of the well site shall be drawn to a scale no smaller than 1" = 5'.

#### 5.00 PLAN DETAILS:

5.01 All plans, approved by the County, will be micro-filmed. Therefore, certain drafting standards have become necessary to produce legible film and subsequent prints. All line work must be clear, sharp and heavy. Letters and numerals must be 1/8 inch minimum height, well formed and sharp. Numerals showing profile elevations shall not be bisected by station grid lines.

5.02 The following details are to be shown on plans submitted for approval. This does not in any way exempt the Consulting Engineer preparing plans from the responsibility of preparing neat, accurate and comprehensive plans in keeping with the standards of the profession.

5.02-1 Title Sheet - On subdivision or improvement plans exceeding three sheets in the set, a title sheet shall be prepared showing the entire subdivision or project complete with County maintenance or sanitation district, subdivision or assessment district, city limits, street names, section lines, grant lines and corners, and the location within the County. The title sheet shall also include an index of the sheets; the Consulting Engineer's name, license number and signature; the date and scale of the drawing; and the blocks for the necessary approval of the Director and other officials.

If the plans are exclusively for sanitary sewers, the title sheet shall conform with Section 57.05 of these Standards and the above.

5.02-2 Title Blocks - Each sheet within the set of drawings shall have an approved title block showing the sheet title, number, date, scale, and the Consulting Engineer's name and license number; the County maintenance or sanitation district, and the name of the subdivision or assessment district.

5.02-3 Right of Way - Right of way lines, the boundaries of lots fronting on the street, drainage easements, utility easements, planting easements, section lines and corners, land grant lines, and temporary construction easements both existing and proposed shall be shown on the plans. All right of way and easement lines shall be properly dimensioned.

5.02-4 Topography - All pertinent topographic features shall be shown such as street lines, curbs, sidewalks, shoulders, location and size of storm and sanitary sewer lines, high water and frequent inundation levels, water and gas lines, existing structures, houses, trees, and other foliage, drainage ditches, utility poles, fire hydrants, and all other features of the area which may affect the design requirements for the area. Any tree which falls within the existing or proposed right of way must be shown on the cross section when requested by the Director. Permission to remove any tree in the right of way must be obtained from the Director.

5.02-5 Profiles - The plans shall show the existing profile of all roadway centerline, edges of pavement, curb and gutter flow lines, drainage ditches, storm and sanitary sewers. All profiles of proposed improvements shall state centerline elevations at fifty foot intervals and rate of grades, vertical curves and other vertical alignment data. Any warped surface shall set elevations at twenty-five feet intervals. All profiles must be coordinated with County stationing. The Consulting Engineer shall contact the County for such stationing.

5.02-6 Stationing and Orientation - The stationing on plan and profile shall read from left to right. Plans shall be so arranged that the north arrow points toward the top or upper 180°, insofar as practical.

5.02-7 Bench Marks - The bench marks and datum shall be clearly pointed out on the plans both as to location, description and elevations. The datum shall be 1929 North American Datum (U.S.G.S. or U.S.C. & G.S.). Consulting Engineers shall contact the County for location and elevation of the nearest official bench mark.

5.02-8 The Director shall require that the proposed improvements be tied into the California Coordinate System if monumented coordinate points are available within a reasonable distance of said improvement as determined by the Director.

5.02-9 Typical Sections - A typical section for each type of street within the improvement, setting out the structural features shall be a part of the plans.

5.02-10 Cross Sections - Cross sections shall be included in the plans, where determined necessary by the Director. When, in limited areas, unusual topographic features or special conditions occur that would affect the work individual cross sections may be shown on the pertinent plan sheet.

5.02-11 Special Notes - Special notes shall be clearly indicated, and it shall be conspicuously noted on the plans that all construction work and installations shall conform to the County of Sacramento Standard Specifications and that all work is subject to the approval of the Director. See Section 3.02.

5.02-12 When the County has agreed to cooperate in any portion of work shown on Consulting Engineer's plans, these plans shall be clearly noted: "Contractor shall submit a proposal to and obtain a work order from the County prior to construction." The County will not pay for any work done without said work order.

## 6.00 INSPECTION DURING CONSTRUCTION:

6.01 Any improvement, other than "rough grading", constructed to County Specifications and which it is intended that the County will assume maintenance responsibility, must be inspected during construction by the Director. Each phase of construction must be inspected and approved prior to proceeding to subsequent phases.

6.02 Any improvements constructed without inspection as provided above or constructed contrary to the orders or instructions of the Director will be deemed as not complying with Sacramento County Specifications and will not be accepted by Sacramento County for maintenance purposes. The Consulting Engineer shall notify the County Construction Office when the Contractor first calls for grades or staking.

2 6.03 For purposes of the inspection requirement above, embankments over two feet in height constructed in dedicated street right of ways are not considered "rough grading". Said "rough grading" does not supersede any provision of Ordinance No. 480 or Drainage Ordinance No. 1, regarding either the diversion or blockage of natural drainage.

## 7.00 FINAL INSPECTION:

7.01 Upon completion of any improvements which are constructed under and in conformance with County Standard Specifications and prior to requesting a final inspection, the area shall be thoroughly cleaned of all rubbish, excess material and equipments, and all portions of the work shall be left in a neat and orderly condition satisfactory to the Director.

7.02 Within 10 days after receiving the request for final inspection, the Director shall inspect the work. The Contractor, Consulting Engineer, and Developer, will be notified in writing as to any particular defects or deficiencies to be remedied. The Contractor shall proceed to correct any such defects or deficiencies at the earliest possible date. At such time as the work has been completed, a second inspection shall be made by the Director to determine if the previously mentioned defects have been repaired, altered, and completed in accordance with County Standard Specifications.



At such time as the Director approves the work and accepts the work for Sacramento County, the Contractor, Consulting Engineer and Developer will be notified in writing as to the date of final approval and acceptance.

On assessment districts and projects where Sacramento County participates on the costs thereof, quantities will be measured in the presence of the Director, Consulting Engineer, and Contractor and witnessed accordingly.

#### 8.00 AS BUILT PLANS:

8.01 One complete set of reproducible plans, as prescribed by the Director, shall be submitted to the Department of Public Works at such time as all corrections or additions requested by the Department of Public Works are complete and approved, and prior to issuance of plans for bidding purposes. These plans are to be retained and utilized by the Department of Public Works for preparing the "as built" plans. Attention is directed to Sections 3.03 and 3.04 of these Standards limiting the alteration of approved plans.

8.02 The Consulting Engineer shall keep an accurate record of all approved deviations from the plans. These are to be utilized with the Inspector's plans for preparing a complete and accurate set of "as built" plans for the permanent records of the County.

#### 9.00 STREET TYPES AND CLASSES:

9.01 Alley - A street depressed in the center, with a right of way and surface width of 20 feet.

9.02 42 Foot Street - Type M.R. - A minor residential street with a right of way width of 42 feet and a back to back curb width of 32 feet.

9.03 54 Foot Street - Type P.R. - A primary residential street with a right of way width of 54 feet, and back to back curb width of 42 feet.

9.04 60 Foot Street - Type M.C. - A minor commercial or minor residential collector street with a right of way width of 60 feet and a back to back curb width of 48 feet.

9.05 80 Foot Street - Type M.A. - A major arterial street with a right of way of 80 feet and a back to back of curb width of 66 feet.

9.06 100 Foot Street - Type M.H. - A major highway with right of way width of 100 feet, a back to back of outside curb width of 88 feet.

110 Foot Street - Type M.H. - A major highway with right of way width of 110 feet, a back to back of outside curb width of 88 or 98 feet. Type M.H. street geometrics may vary as determined necessary by the Director.

9.07 Type "I" Street - Proposed street improvement in an industrial development or industrial subdivision having an asphalt concrete surface on an aggregate base with a modified "V" gutter and no sidewalks. Width is variable and subject to approval by the Director.

9.08 Type "F" Street - A street which serves as a frontage road having curbs, curb and gutters, and sidewalk.

9.09 Partial Street - A street for which the full right of way can not be dedicated or the complete street can not be constructed.

9.10 Class "A" Streets - Proposed street improvement for all single family residential development having a net average size of 14,500 square feet per lot or less, or an average lot street frontage of 100 feet or less shall be Class "A". The net square footage of said residential developments shall be considered to be that portion of the total square feet excluding the areas required for street right of way, fenced easements and parkways. Lots or parcels in excess of 16,000 square feet shall not be considered in averaging the lot areas. Lots having a street frontage in excess of 150 feet shall not be considered in averaging street frontages. Class "A" streets shall have an asphalt concrete surface and an aggregate base with concrete curb and gutter, sidewalks and side slopes not exceeding a maximum of 1:1 or a reinforced concrete retaining wall beginning at the right of way line. Class "A" street improvements are required for all developments which are zoned R-1-B to C-2 inclusive, regardless of the individual lot frontage or area and for all developments requiring improvements under Ordinance No. 761 and amendments thereto.

9.11 Class "B" Streets - Proposed street improvements for all single family residential developments having a net average lot area of more than 14,500 square feet, and an average lot street frontage of more than 100 feet may be Class "B" and shall have the same components as Class "A" except that sidewalks may be omitted. In no case shall more than 20 percent of the lot street frontages be less than 100 feet. The net square footage of said residential development shall be considered to be that portion of the total square footage excluding the areas required for street rights of way, fenced easements, and parkways. Lots or parcels having 2,500 square feet in excess of one-half acres shall not be considered in averaging the lot area.

9.12 Class "C" Streets - Proposed street improvements for agricultural area developments requiring public road frontage, and all single family residential developments having a net average lot area of more than one-half acre, and an average lot street frontage of more than 125 feet may be Class "C" and shall have the same components as Class "A", except that curb, gutters and sidewalks may be omitted. The net square footage of said residential developments shall be considered to be that portion of the total square footage excluding the areas required for street rights of way, fenced easements and parkways. In no case shall more than 20 percent of the lot street frontages be less than 125 feet. No lot shall have a net area of less than 20,000 square feet.

9.13 Type 1 curb and gutter may be installed for all developments zoned single family residential on all streets excepting 100 foot and 110 foot streets, and for all developments zoned R-1-B through R-3 on 42 foot, 54 foot and 60 foot streets. Type 2 curb and gutter shall be installed for school and commercial developments on all streets, and for all developments on 80 foot and 100 foot streets excepting single family residential on 80 foot streets. All school developments shall have 8 foot sidewalks along all frontage except fenced play areas where no access is provided, as determined by the Director. All fences along schools shall be set back a minimum of 8' from back of curb regardless of sidewalk width. The area between the sidewalk and fence shall not exceed 10 percent cross slope. Type 6 curb and gutter may be installed on the internal streets of all developments, zoned M-1 and M-2, The Director may require the replacement of Type 1 curb and gutter with Type 2 curb and gutter, if property is rezoned to a classification which would normally require said curb and gutter type.

9.14 Barrier curb shall be required for all commercial and multiple family developments, all other locations where parking will be allowed adjacent to the sidewalk, and as may be required by the Director. Barrier curb shall be Type 3, 4, or 5 and placed as shown on Standard Drawing A-7.

## 10.00 PROFILES:

10.01 The following standards for the design of profiles for proposed improvement shall govern the preparation of plans for such improvements.

### 10.02 Minimum Grades and Cross Slopes:

- a. Minimum grade on new streets shall be 0.25 percent.
- b. Minimum grade of gutter section constructed on existing street shall be 0.20 percent.
- c. Minimum cross slope on new streets shall be 2.0 percent.
- d. Minimum cross slope on widening shall be 1.5 percent.
- e. When two streets intersect, neither street shall have a grade greater than 3.0 percent for a minimum distance of 40 feet measured from the curb line of the intersecting street, except in unusually rough terrain, as determined by the Director.
- f. The minimum vertical curve length allowable at the intersection of two grades shall be 50 feet, however, vertical curves may be omitted where the algebraic difference in grades does not exceed 2.0 percent.
- g. The minimum stopping sight distance over any segment of the roadway on 42 foot, 54 foot or 60 foot streets shall be 200 feet unless specific approval for a lesser distance is received from the Director.
- h. Minimum stopping sight distance to be provided on 80 foot and 100 foot streets shall be determined by the Director.

## 11.00 GEOMETRIC AND STRUCTURAL SECTIONS:

11.01 The following standards for the design of geometric and structural sections for proposed improvements shall govern the preparation of plans for such improvements.

11.02 The limits of elevation differences between the existing centerlines and the proposed flow line of gutters are as follows:

42 foot streets	0.37 foot to 0.56 foot
54 foot streets	0.44 foot to 0.71 foot
60 foot streets	0.50 foot to 0.80 foot
80 foot streets	0.62 foot to 1.07 feet
100 foot streets	0.78 foot to 1.40 feet

11.02-1 The above minimum and maximum street crowns are to be used on existing or irregular streets. Street section shall conform as closely as possible to standard typical section of 2 percent cross slope.

11.03 No cross gutters will be allowed on 60 foot, 80 foot and 100 foot streets. Cross gutters will be permitted on 42 foot and 54 foot streets with the specific approval of the Director when the intersection cannot be drained to an underground system.

11.04 The curve data for all centerline curves shall be computed and shown on the plans. Minimum radius curve for 42 foot and 54 foot streets shall be 125 feet. Minimum radius curve for 60 foot streets shall be 250 feet. Minimum radius curve for 80 foot and 100 foot streets shall be 1000 feet. Special consideration will be given to unusually difficult alignment problems. Right angle intersection shall be designed to conform with Standard Drawing A-14.

11.05 The radius for property line in cul-de-sacs shall be 45 feet unless otherwise specified by the Director. A curve of 55 foot radius shall connect the tangent and the 45 foot radius curve. See Standard Drawing A-10.

11.05-1 Industrial cul-de-sac streets shall have a minimum property line radius of 60 feet and shall be constructed on a 60 foot street or larger.

11.06 Driveways entering Class "B" or "C" streets shall meet the property line at such a grade and elevation as to permit conversion to a Class "A" street without regrading the driveway beyond the property line. Maximum driveway slope shall be 10 percent.

11.06-1 Concrete driveways will not be permitted within the right of way lines when entering Class "C" streets.

11.06-2 No driveway will be allowed within 10 feet of a side property line on a commercial development, except as specified by the Director.

11.06-3 The minimum width for driveway section shall be 12 feet for residential and 20 feet for commercial. The maximum width shall be 24 feet for residential and 35 feet, with a minimum of 20 feet between the driveways, for commercial developments, as shown on Standard Drawing A-6. Large developments may use driveways as shown on Standard Drawing A-7, as specified by the Director.

11.06-4 For allowable driveway spacing, see Standard Drawing A-8.

11.07 Pedestrian walks and lanes within a development shall be constructed with a minimum of 4 inches of Portland cement concrete, Class "B", for the full width of the easement. Easement shall be not less than 10 feet in width. Pedestrian walks, if situated between lots, must be fenced with chain link fencing from the street right of way to the back lot line. These fences shall be 6 feet high from the setback line to the back lot line and 30" high from the setback line to the street right of way. Two firmly planted 3 inch capped pipes, 3 feet high, shall be placed equally spaced in the pedestrian walk at the street right of way line.

11.08 Partial streets may be permitted by the Director along the boundary of a subdivision or property of the developer where the full right of way can not be dedicated or where the complete street can not be constructed. The minimum right of way width shall be 40 feet or one-half of the proposed right of way, whichever is greater. Such streets shall be constructed to a complete structural section for a minimum of 24 feet or one-half of the proposed roadway, whichever is greater.

11.09 Minimum allowable thickness of roadbed section shall be as follows:

11.09-1 2" asphalt concrete and 4" aggregate base on 42 foot and 54 foot streets.

11.09-2 3" asphalt concrete and 6" aggregate base on 60 foot streets.

11.09-3 3" asphalt concrete, 6" aggregate base and 6" aggregate subbase on 80 foot and 100 foot streets.

11.09-4 Structural section for Type "I" streets will be determined on an individual basis.

11.09-5 Consulting Engineers shall use paving sections established by the Director for streets other than 42 foot and 54 foot where such sections have been established.

11.10 In those areas considered by the Director as being critical soil condition areas, it will be required that the pavement be designed on the basis of the resistance factor "R" as determined in accordance with Division of Highways, State of California, California Bearing Ratio, or other approved method.

11.11 The thickness of the various structural components will be determined by the tables, charts, formulas and procedures contained in the State Design Manual, or as directed by the Director.

11.12 Traffic index will be furnished by the Director.

11.13 Asphalt headers - When paving partial streets at the end of initial construction of the ultimate development, a 2" x 6" redwood header will be required to protect all edges of the asphalt concrete pavement. The grading of the redwood timber shall be as specified in Section 57-2.02 of the State Specifications. An additional one foot width of pavement may be substituted for the header board with approval of the Director.

## 12.00 SURVEY MONUMENTS:

12.01 The Consulting Engineer shall place survey monuments at the following locations within the improvement.

12.01-1 At the intersection of all street centerlines.

12.01-2 At the beginning and end of curves on the street centerline.

12.01-3 At all subdivision boundary corners designated by the Director; at the intersection of subdivision boundaries and street centerlines and such other locations so as to enable any lot or portion of the improvement to be retraced or located.

12.02 The above prescribed monuments shall be as follows:

12.02-1 Subdivision boundary monuments except those in street pavement shall be not less than 1-1/4 inch galvanized iron pipe 30 inches in length, capped and tagged.

12.02-2 Subdivision boundary monuments in street pavement shall be not less than 3/4 inch galvanized iron pipe 18 inches in length. Top of pipe shall be driven flush with surface pavement.

12.02-3 Centerline and street intersection monuments shall be 3/4 inch galvanized iron pipe or No. 4 reinforcing bar, not less than 12 inches in length. Top of the pipe or bar shall be driven flush with pavement surface.

12.02-4 All such monuments shall be referenced to permanent objects located nearby and all ties shall be furnished the Director for general public use. Final approval of the subdivisions will not be made until such ties have been furnished to the Director.

12.03 Permanent survey monuments shall be placed by the Consulting Engineer at all section and quarter corners within the improvement. The section corner monuments shall be Class "B" concrete, poured in place, with minimum dimensions of 4" x 4" x 24". A metal survey plate will be furnished and marked by the Department of Public Works to be installed by the Consulting Engineer. Plates shall be placed before the concrete has acquired its initial set and shall be firmly embedded in the concrete.



12.04 The Consulting Engineer shall place a note on all construction plans stating that the Contractor is responsible for the protection of all existing monuments and other survey markers.

13.00 TESTING OF MATERIALS:

13.01 Testing of materials to be utilized in work performed under Standard Specifications shall be performed in accordance with the methods of the Laboratory of the California Division of Highways. Signed copies of the test results as required shall be submitted to the Director. Test results shall show clearly the name of the individual and the firm performing the tests, as well as the name of the project, the date of sampling, and the date of testing.

13.02 The tests indicated in the Standard Specifications will be required. In large developments or those developments presenting special problems, a more comprehensive and extensive testing program may be required. Such conditions will be evaluated and an appropriate testing program prescribed on an individual basis. Two copies of any Federal Housing Administration required soils tests shall be submitted with proposed plans.

14.00 RIGHT OF WAY:

14.01 Minimum right of way widths shall be as set out in these Standards for the type of street under consideration or as determined by the Director. In no instance, without specific approval of the Director, shall a street have a right of way width which is less than the street of which it is a continuation. Right of way requirements for widening at intersections shall be as shown in the Standard Drawing No. A-13, A-14, or as approved by the Director.

15.00 SIGNING AND BARRICADES:

15.01 Street Names - All roads and streets within an improvement shall be named by the owner or subdivider. No duplication of names already in use or previously proposed will be permitted. Street name signs shall be furnished and erected by the Contractor. Street signs shall conform to requirements of the Standard Specifications. Location of signs and street names shall appear on plans submitted for approval.

15.02 Permanent Barricades - Where improvement only cover a portion of the ultimate improvement and where an improved street is proposed to be extended in the future, the improvements shall include a permanent type barricade at the end of such a street to extend completely across the right of way to serve as a warning to the public. The barricade shall be constructed, erected, painted, and signed in accordance with the Standard Specifications, Standard Drawing No. D-2. When necessary, barricades may be lengthened by making the 2" x 12" plank continuous, splicing at the posts.

## 16.00 STORM DRAIN DESIGN STANDARDS:

16.01 Classification - Modifications to the following classifications may be required by special conditions. Any such modifications or questions concerning classification will be resolved on an individual basis, between the Consulting Engineer and the Director. Either party may initiate action to reclassify a drainage conduit in lieu of the area drained classification.

16.01-1 Lateral - Drainage conduits receiving drainage from areas of less than thirty acres.

16.01-2 Collector - Drainage conduits receiving drainage from areas of thirty acres or more, but less than one hundred acres.

16.01-3 Trunk - Drainage conduits receiving drainage from areas of one hundred acres or more.

## 17.00 ALIGNMENT AND CAPACITY:

17.01 Capacity - Special provisions must be made within the drainage system to insure that the inlet flow line elevations and the capacity of the drainage system is such that it may be extended to serve and to properly handle the entire drainage basin at the time of ultimate development. This is to include the entire upstream portion and the portion of the basin outside the development regardless of existing conditions.

17.02 Alignment - The diversion of natural drainage will be allowed only within the limits of the proposed improvement. All natural drainage must leave the improved area at its original horizontal and vertical alignment unless a special agreement, approved by the Director has been executed with the adjoining property owners.

17.03 The location of storm drainage lines in new streets shall be 6 feet north or west of the centerline or under the curb and gutter. When pipes are placed under curb and gutter, the minimum clearance shall be 3 inches between bottom of gutter section and top of pipe, and backfill material shall be sand or pea gravel.

17.04 When storm drainage lines are to be placed in existing streets, factors, such as curbs, gutters, sidewalks, traffic conditions, pavement conditions, future street improvement plans, and existing utilities shall be considered. Approval of the Director will be required in every case. Other general requirements for alignment are as follows:

17.04-1 Lines are to be parallel with the centerline of streets as nearly as possible.

17.04-2 Avoid meandering, and unnecessary angular changes.

17.04-3 Angular changes shall not exceed 90 degrees.

17.04-4 Provide junctions between combining lines in such a manner as will minimize losses and utilize available velocity head, to locate the centerlines of the influent and effluent lines to lie approximately in the same plane and to be as nearly as possible parallel to the resultant vector of the respective flowing components.

17.04-5 Open ditches, paved channels, and swale flows shall be maintained as nearly as possible in their existing alignment. When an open ditch is to be graded parallel to an existing roadway the ditch shall be constructed outside the proposed roadway of the ultimate street development.

17.04-6 The vertical alignment shall be so designed to preclude any ponding within the drainage system.

## 18.00 EASEMENTS:

18.01 Drainage conduits and channels when not located in a public street, road or alley, or within an existing public drainage easement, must be located in a recorded or dedicated public easement over private property. Necessary dedication for construction on private property must be completed before the improvement plans will be approved for construction. Where a minor improvement of a drainage channel falls on adjacent property, such as daylighting a ditch profile, a right of entry must be obtained from the adjacent property owners for such construction, and a copy of the right of

entry from the adjacent owners shall be submitted to the Director prior to approval of the improvement plans. In general, drainage easement will have simply-described boundaries (described in brief) and simple form and referenced to a well defined point or line.

18.02 Easements for closed conduits shall meet the following requirements.

18.02-1 Minimum width of ten feet with the centerline of the pipe at quarter point; pipe may reverse sides at angle points.

18.02-2 Provide access and working space rights.

18.02-3 On pipe of 24" diameter and greater or trenches exceeding 5 feet in depth, the easement will have additional width to provide ample working space as required by the Director.

18.03 Easements for open conduits shall have sufficient width to contain the open channel with side slopes, and a fifteen foot service road. If the bottom width of the channel is 5 feet or greater, access for maintenance may be provided along the bottom of the channel. Suitable ramps must be provided for access to the bottom, and 4 inch thickness of concrete shall be placed on the bottom.

19.00 DESIGN RUNOFFS:

19.01 The runoffs to be used in storm drainage design for drainage areas 160 acres and smaller shall be computed from the drainage zones as shown on Standard Drawing C-1 and the accompanying graphs on Standard Drawings C-2 and C-3. For commercial areas, the runoff shall be increased fifty percent or a minimum of 0.5 C.F.S. per acre whichever creates the larger quantity.

19.02 The runoffs to be used in storm drainage design for drainage areas over 160 acres shall be computed from Plates 4, 5, 6, 7a, 7b, 7c of the County of Sacramento Master Drainage Plan, Part I, County Wide Hydrology, October 1961. Unless otherwise approved by the Director, the medium density runoff for urban watersheds and improved channels shall be used.

19.03 Ultimate Development - In computing runoff in a partial development, adequate provisions must be made for the drainage of the overall improvement including possible commercial areas.

19.04 Hydraulic Gradients - Hydraulic grade line shall be a minimum of 0.50 feet below the elevation of inlet grates and manhole covers of all structures of the upstream system. Hydraulic grade line at the intake must enter the conduit at the property line.

20.00 HYDRAULIC DESIGN CRITERIA:

20.01 In order to provide a uniform drainage system in the County of Sacramento, the following criteria will be followed in all hydraulic computations unless specific approval otherwise is received in writing from the Director.

20.02 Flow computations - All flow computations shall be in accordance with the following.

20.02-1 Manning's Formula shall be used to compute capacities of all open and closed conduits other than cross culverts. (Refer to Bureau of Public Road charts for solutions of Manning's Formula.)

20.02-2 King's Formula shall be used to compute the capacity of all cross culverts. (Refer to King's Handbook of Hydraulics, 4th Edition, page 3-23 and California Division of Highways nomographs for the solution of King's Formula.)

20.02-3 The 'N' values to be used in Manning's Formula shall conform to the following:

Precast Pipe	0.015
Concrete cast-in-place (Fuller Form)	0.015
Concrete cast-in-place (No Joint)	0.0165
Vitrified Clay Pipe	0.013
Asbestos Cement	0.013
Corrugated Metal Pipe (C.M.P.) Plain Unlined	0.021
Corrugated Metal Pipe (C.M.P.) Paved Invert	0.019
Corrugated Metal Pipe (C.M.P.) 100% Paved	0.015
Open Channel Fully Lined	0.015
Earth Channel	0.030

20.03 Closed Conduits - Shall be of either cast-in-place or precast reinforced concrete pipe, non-reinforced concrete pipe, asbestos cement pipe, vitrified clay pipe or corrugated metal pipe.

20.03-1 Minimum pipe diameter allowable on any storm drain shall be 8 inches.

20.03-2 Any conduit, other than short runs not to exceed 80 feet, draining single gutter inlets into manholes or other junction inlet and roadside drain culverts shall be a minimum of 10 inches.

20.03-3 Driveway culverts shall be approved by the County for size, grade, alignment and type. Contractor shall contact County for stakes. Driveway culverts for R-1 through R-3 property shall not exceed length necessary for 24 feet maximum driveway width, and for C-1 through M-2 shall not exceed length necessary for 35 feet maximum driveway width. Driveway culverts will not be allowed unless the County has agreed to defer the normal Class "A" or Class "B" street improvements, except for temporary construction access.

20.03-4 Minimum velocity in closed conduits shall be 2 f.p.s. at design flow.

20.04 Corrugated metal pipe may be either steel or aluminum, except that aluminum shall not be used in any roadway area without permission of the Director.

20.04-1 The use of corrugated aluminum pipe will be considered as alternate to concrete pipe or corrugated steel pipe, only under the following conditions:

- a. Within "off street" easements.
- b. The depth of cover over the pipe is less than 20 feet.
- c. Between concrete structures such as manholes, inlets, and junction boxes.
- d. Aluminum pipe shall be separated from other metals a minimum of one inch by the use of concrete or other insulating material acceptable to the Director.

20.05 Asbestos cement pipe shall conform to the A.S.T.M. Designation C428 with plastic sleeve couplings designed to maintain pipe alignment and insure tight, flexible joints. All applicable methods of construction shall conform to Section D3 of the Standard Specifications.

20.06 Cover requirements are shown on Chart C-5, C-5A, and C-5B, "Cover Requirements" of the Standard Drawings. At locations where the general minimum cover requirements cannot feasibly be obtained, the conduit will be either encased in concrete or provided with a concrete cover or another method of pipe protection as specified by the Director for each individual circumstance.

20.07 Open Conduits - Shall consist of concrete lined channels, paved bottom channels, or natural earth channels.

20.07-1 Minimum velocity

- a. Unlined channels 2 f.p.s.
- b. Lined channels 2 f.p.s.
- c. Paved invert channels 2 f.p.s.

20.07-2 Maximum velocity

- a. Earth channels 6 f.p.s.
- b. Lined channels 10 f.p.s.
- c. Paved invert channels 8 f.p.s.

20.07-3 For all channels with earth sides, freeboard of at least one foot shall be provided at design capacity for a 10 year storm. For lined channels freeboard of at least 0.5 foot of lining shall be provided at design capacity for a 10 year storm.

20.08 Design Computations - The design computation for drainage shall include the following information:

- a. Drainage area in acres.
- b. C.F.S. to each structure.
- c. C.F.S. in each pipe.
- d. Flow line elevation of each pipe and structure.
- e. Top of structure elevation.
- f. Hydraulic elevation at each structure.
- g. Hydraulic gradient.
- h. Pipe, size, class, length and gradient. Items f and g not required when design is based on hydraulic grade line inside conduit.



## 21.00 DRAINAGE STRUCTURES:

21.01 The design and construction of drainage structures and special drainage items shall conform to the requirements contained in these Standards and the Standard Specifications. Special care must be taken to insure that all drainage structures and pipe are designed at such a capacity that the drainage system may be extended to serve the entire drainage basin at ultimate development.

### 21.02 Manholes

21.02-1 Standard precast concrete, saddle type concrete or prefabricated steel manholes will be used whenever feasible. Steel manholes will be subject to the approval of the Director. When cases arise where special manholes or junction boxes are required, the design must be approved by the Director. In no case will junction boxes or manholes be allowed which are smaller than twenty-four inches inside diameter.

21.02-2 Manholes shall be located at junction points, changes in gradient, and changes in conduit size. On curved pipes with radii of 200 feet to 400 feet, manholes shall be placed at the B.C. and E.C. of the curve and on 300 feet maximum intervals along the curve. On curves with radii exceeding 400 feet, manholes shall be placed at the B.C. and E.C. of the curve and on 400 feet maximum intervals along curve for pipes 24 inches and less in diameter and 500 feet maximum intervals along the curve for pipes greater than 24 inches in diameter. Manholes located on curves with radii less than 200 feet will be handled on an individual basis.

21.02-3 Spacing of manholes or inlets of such size as to be enterable for maintenance shall not exceed 400 feet for drains 24 inches and smaller in diameter and 600 feet for pipes greater than 24 inches in diameter, except under special approved conditions. The spacing of manholes shall be nearly equal wherever possible.

21.02-4 All manholes shall have standard manhole covers, as shown in detail C-28. Manholes will not be allowed in gutter line except as approved by the Director.

21.02-5 For pipes 24 inches or less in diameter, channelization in the manhole may be required as shown on Standard Drawing C-14 and Standard Drawing 910-S-2. Sumps will not be generally required on manholes, however, they may be required at the discretion of the Director.

21.02-6 When any pipe would enter a manhole above the base of the taper, a reinforced concrete lid as shown on Standard Drawing C-17 will be required.

### 21.03 Inlets

21.03-1 Gutter inlets shall be in accordance with those types shown in the Standard Drawings or other approved special inlets.

21.03-2 Inlets shall be spaced so that gutter flow does not exceed 500 feet and so as to intercept all flow draining to the inlet.

21.03-3 Inlets at major low points shall be Type 1, 2, 3, or other approved special inlet types and the outfall line shall be designed to accommodate a 10 year design storm, taking into account, bypass from previous inlets.

21.03-4 The restrictive uses of the smaller type inlets as noted on the Standard Drawings shall be adhered to unless special approval is received.

21.03-5 Type 1, 2, or 3 inlets may be used as junction inlets but only if the flow line is 4 feet or less below the grate elevation. Type 5 may be used as junction box for small pipes in a longitudinal direction only.

21.03-6 When the elbow on a gutter drain will not fit the elevation of the 8 inch pipe connection to the manhole, a Type 5 drop inlet must be substituted for the gutter drain.

21.03-7 Type 6 inlet shall be used in unimproved medians.

## 21.04 Junction Boxes

21.04-1 Junction boxes will be constructed of Class "A" reinforced Portland cement concrete or fabricated from reinforced concrete pipe sections where size limitations permit. Standard manhole ring and cover shall be used.

21.04-2 Minimum wall thickness for poured in place reinforced concrete junction boxes shall be 6 inches.

21.04-3 The inside dimension of junction boxes shall be such as to provide a minimum of 3 inches clearance on the outside diameter of the largest outfall pipe.

21.04-4 All junction boxes shall have the standard 24 inch manhole cover. Junction boxes in the gutter line shall use the standard grate Type 1 to serve as cover for access opening.

## 21.05 Wye Connections

21.05-1 Precast wye connections may be used only to connect one gutter drain into a collector or trunk drain with a diameter of 24 inches or greater, and in accordance with the following conditions and limitations.

21.05-2 If more than 2 inlets occur at one location, wye connections will not be permitted.

21.05-3 All wyes shall make an angle of no greater than 45 degrees with direction of flow in the intersected line.

21.05-4 Yard drain lines may be connected to any County maintained drainage pipe with wyes subject to Section 21.05-1. The Contractor must obtain an Encroachment Permit unless said connection is shown on County approved plans.

21.05-5 45 degree cut curves may be utilized for yard drains and inlets in order to facilitate the wye connection.

21.05-6 Limitation as to manhole spacing must be adhered to.

21.06 Reinforced Concrete Box Culverts, C.M.P. and Structural Plate Arch Culverts.

21.06-1 When specified by the Director, R.C. box culverts, C.M.P., or structural plate arch culverts shall be installed.

21.06-2 All materials, design, and construction shall conform to the requirements of the State Specifications, State Standard Drawings, County Standard Specifications and Standard Drawings.

21.07 Headwalls, Wingwalls, Endwalls, Trash Racks and Railings

21.07-1 All headwalls, wingwalls, and endwalls shall be of Class "A" reinforced Portland cement concrete.

21.07-2 All headwalls, wingwalls, and endwalls shall be considered individually and shall be, in general, designed in accordance with the Standards and Specifications of the California Division of Highways or the Sacramento County Department of Public Works.

21.07-3 Trash racks will be provided where, in the opinion of the Director, they are necessary to prevent clogging of culverts and storm drains and eliminate hazards. The trash racks shall be designed in conformance to the design shown in the Standard Drawings. Temporary trash racks will be allowed where pipe will be extended in the near future.

21.07-4 On culvert drains, pre-formed end sections may be utilized with the approval of the Director.

21.07-5 Metal beam guard rail may be required by the Director at culverts, headwalls and box culverts and on steep side slopes. When so required, the railing shall be installed in accordance with Section H37 or H38 of the County Standard Specifications.

21.08 Drainage Wells

21.08-1 The use of drainage wells will not be accepted, unless they will be eliminated by future development in a manner and time approved by the Director. Drainage wells shall conform to Standard Drawing C-22.

## 21.09 Drainage Pumps

21.09-1 The use of drainage pumps shall be avoided whenever possible, and used only with the specific approval of the Director.

21.09-2 If the use of drainage pumps is permitted, the drainage system shall be so designed as to provide for gravity outfall during the summer months and other periods of low water stages. If a low stage gravity outfall is impossible or impractical, an alternate pump of smaller capacity for low stage flow may be used provided specific approval is granted by the Director.

21.09-3 The outfall shall be equipped with flood gates of an approved design. The gravity flow outfall shall also be equipped with a positive method of preventing reverse flow during periods of high stage flow.

21.09-4 Pumping installations shall be designed to accommodate a design storm as specified by the Director. When a station contains gravity discharge, pumping capacity must be equal to the design inflow. When the station does not have a gravity discharge, pumping units must be designed to furnish 100% capacity with any one pump out. Any deviation from this criteria must receive the specific approval of the Director.

21.09-5 Pumping stations shall be so designed that gravity flow does not pass through the pump pit.

21.09-6 No motor overload condition shall exist at any sump or flow condition. This does not preclude high sump design if low sump condition does not create an overload.

21.09-7 Each pumping installation shall receive separate approval for each of the following items: electrical system, piping system, housing installation and other miscellaneous design features.

21.09-8 The electrical system for drainage pumps shall conform to Section E of the County Standard Specifications.

21.09-9 Adequate access shall be provided for cleaning the pump sump.

21.09-10 Trash racks shall be provided upstream from the pumping plant. Provisions shall be made for easy cleaning of the trash racks.

21.09-11 Hatch covers, where used, shall be of raised pattern aluminum floor plate, or other approved lightweight cover. Dissimilar metals shall be insulated from each other when necessary.

21.09-12 Ladder rungs, where used, shall be of a non-slip variety.

## 21.10 Temporary Drainage Diversions

21.10-1 Temporary drainage diversions, such as dams and pipe plugs, shall be located and constructed in such a fashion as to permit their removal during adverse weather.

21.10-2 Locations and removal procedures for temporary drainage installations shall be approved by the Director, and these installations shall be removed when necessary to prevent damage to adjoining property.

## 21.11 Conductor Pipe

21.11-1 Pipe used as a conductor pipe under a highway, or railroad, shall be either welded steel pipe, or corrugated metal pipe. The Director may specify which type shall be used in any instance. The protective lining and coating, if any, shall be as shown on the plans or specified in the Special Provisions.

21.11-2 Welded steel pipe shall conform to the Standard Specifications, Section S1-03.

21.11-3 Corrugated metal pipe shall conform to the Standard Specifications. Band couplers shall be of the same metal as the pipe.

21.11-4 When the conductor pipe is to be installed by boring and jacking, the material shall be No. 10 gauge or thicker. The sections of pipe shall be especially prepared for making field joints by riveting or bolting. If the joints are bolted, the bolts shall

be 3/8 inch diameter and galvanized. Rivets shall be of the same material as the base metal used for the corrugated sheets and shall be galvanized or sherardized.

## 22.00 CHANNELS, OUTFALLS, AND CROSS CULVERTS:

22.01 All channel realignments, improvements and cross culverts shall be shown on the improvement plans and shall conform to the requirements of these Standards and Specifications. No diversion to roadside ditches will be allowed.

### 22.02 Open channels

22.02-1 Drainage may be conducted through an improvement in open channels under the following criteria and if approved by the Director.

- a. The quantity of flow is such that it will exceed the capacity of a 54 inch pipe.
- b. The outfall point is such an elevation that minimum cover cannot be obtained over the pipe.

22.02-2 All channels shall be lined with concrete either airblown or poured in place, to an elevation of 0.5 feet above the 10 year design water line. The channel bottom shall be constructed using poured in place concrete. The side slope shall not exceed 1:1 on the lined portion and 1½:1 on the unlined portion above the top of the concrete lining. The channel flow line will be located along the toe of the channel bottom and the minimum bottom width will be 5 feet.

22.02-3 All underbrush and debris shall be removed from the channel cross section with the exception of certain trees which may be utilized to beautify the area. All such trees shall be shown on the plans and those to be left in place so designated. All abrupt changes in the alignment or profile of the natural channel which seriously restricts flow shall be improved and regraded.

22.02-4 For all channels, either realigned or natural, with an improvement, the following shall be shown on improvement plans in addition to information heretofore required.

- a. Typical sections and cross sections if requested.
- b. Profile of the existing channel and top of bank profile for a minimum of 1000 feet each side of the development in order to establish an average profile grade through the development. The County has established profiles for major drainage channels. The Consulting Engineer shall contact the County for such profile information.

### 22.03 Outfalls

22.03-1 All drainage outfalls shall be shown both in plan and profile on the improvement plans for a distance of 1000 feet or until a definite "daylight" condition is established.

22.03-2 When improvements have more than one unit the drainage outfall shall be shown as extending to the property boundary, and beyond if required, although it may not be constructed with the current unit development. All temporary outfalls shall be shown both in plan and profile on the improvement plans.

### 23.00 CROSS CULVERTS:

23.01 Cross culverts may be of reinforced concrete culvert pipe or corrugated metal pipe meeting the requirements of the Standard Specifications.

23.01-1 Cross culvert size shall be determined on the basis of runoff as specified in Section 19.00 of these Standards. A 10 year storm with no head on the inlets shall be used.

23.01-2 Cross culverts shall be checked on the basis of the runoff obtained as specified in Section 19.00 of these Standards plus 25 percent to determine that no serious damage will be incurred due to ponding as a result of the higher design storm which is equivalent to a 25 year storm.



23.01-3 Cross culvert profile will be determined by an examination of the overall profile of the channel for a minimum distance of 500 feet each side of the installation.

24.00 FENCING:

24.01 All open channels exceeding 3 feet in depth, unless otherwise specified by the Director, shall be enclosed by a 6 foot chain link fence. The fence and its installation shall conform to the requirements of the Standard Specifications.

24.02 Chain link fence for drainage channel enclosure shall be with or without extension arms and barbed wire as determined by the Director.

24.03 Drive gates and walk gates shall be provided complete with master keyed locks and keys at such locations as specified by the Director for the purpose of maintenance vehicles and personnel.

24.04 The fence shall be located 6 inches within the required easement lines and shall provide sufficient room for maintenance vehicles where a service road is specified.

24.05 A service road shall be provided within the easement of all open channels that cannot be maintained from within the channel. The road shall be 15 feet wide, graded for vehicle passage, and clear of trees, shrubbery and other obstructions for its full width.

## 25.00 STREET LIGHTING DESIGN STANDARDS:

25.01 Street lighting shall be designed in conformance with the current edition of the "American Standard Practice for Street and Highway Lighting" of the American Standards Association.

25.02 The electroliers shall be energized by an underground multiple electrical system unless otherwise approved in writing by the Director. Utility owned or leased lights will be accepted by prior approval of the Director. Utility owned or leased lights shall conform to the standards as described in Sections 25.01, 27.01 and 28.01 and shall be designed by the Department of Public Works.

## 26.00 MATERIALS:

26.01 Conduit to be installed underground, on the surface of poles, or in structures shall be rigid metal type, conforming to Article 346 of the National Electrical Code, hereinafter referred to as the Code.

26.02 Exterior and interior surfaces of all conduit and fittings shall be uniformly and adequately zinc coated by the hot-dipped galvanizing process. The interior as well as the exterior of a six-inch sample cut from the center of a standard length of conduit when tested in accordance with the applicable portions of A.S.T.M. Designation A239, shall show no fixed deposit of copper after four one-minute immersions in the standard copper sulphate solution.

26.03 The interior of the conduit shall have a continuous coating of lacquer or enamel. Each length shall bear the label of Underwriter's Laboratories, Inc. Installation shall conform to appropriate articles of the Code.

26.04 The size of conduit used shall be shown on the plans. Conduit smaller than one-inch electrical trade size shall not be used, except that grounding conductors at service points may be enclosed in 1/2 inch diameter conduit. Where a pullbox is installed adjacent to a lighting standard base, the conduit installed between the pullbox and the base shall be not less than 1-1/4 in diameter, unless otherwise approved by the Director.

## 27.00 LIGHTING STANDARDS:

27.01 All standards shall be steel, aluminum or concrete shafts having a continuous taper. Steel and aluminum shafts shall have only one vertical seam which shall be rolled smooth. Standards with bracket-arm shall be equipped to take a two-inch slip-fitter type luminaire. The standard shall be shown on the plans, or described in the Special Provisions.

27.02 The length of the mast-arm, the mounting height, and the protective coating shall be shown on the plans, or in the Special Provisions.

27.03 Street lighting standards shall sustain a vertical load of one and one-half times the weight of the luminaire to be used, but in no case less than 250 pounds, applied at the luminaire attachment point, without collapse or rupture of any portion of the structures.

27.04 Standards shall sustain a horizontal load equal to the weight of the luminaire to be used, but in no case less than 50 pounds, applied at the point of luminaire attachment and normal to the plane of the pole bracket member, with a horizontal deflection of not more than five percent of the horizontal length for the luminaire supporting arm. They shall also sustain a horizontal load of 500 pounds applied at the top of the shaft in any direction, without failure of any component part, and with a deflection of not more than five percent of the pole shaft length.

27.05 Standards designed to receive underground supply conductors shall have a covered hand hole with a minimum dimension of three inches and an opening area not less than 24 square inches. All edges shall be made smooth to afford safety from cuts to the workers hand or to the wire insulation. The hand hole framing shall incorporate sufficient reinforcement so no loss of pole shaft strength results. The hand hole shall be so positioned that it will be centered 90 degrees clockwise from the centerline of the bracket as viewed from above.

27.06 Steel street lighting standard shall have provisions for grounding which will permit compliance with the requirements of the National Electrical Safety Code.

28.00 LUMINAIRES:

28.01 The luminaires shall be either filament, mercury vapor, or fluorescent type as specified on the plans or in the Special Provisions. They shall consist of a slip-fitter aluminum hood for internal wiring, an aluminum reflector, and refractor or deflector and glove as necessary to produce light patterns as specified by the Illuminating Engineering Society. The optical assembly shall be of the Roller-Latch type, or approved similar type. All luminaires shall conform to the appropriate section of the standards of the National Electrical Manufacturers' Association, hereinafter referred to as N.E.M.A.

29.00 LAMPS:

29.01 Lamps are to be standard lamps to fit the luminaires specified, without adaptors. The type of lamp and the lamp power is to be shown on the plans. All lamps shall be of the group replacement type; mercury vapor lamps shall be of the color improvement type unless otherwise approved by the Director.

30.00 BALLASTS:

30.01 Ballasts for fluorescent lighting to have internal automatic reset thermal protectors.

30.02 Ballasts for mercury vapor lighting shall be individually fused in each leg that is above ground.

31.00 PULLBOXES:

31.01 Pullboxes and extensions shall be precast reinforced concrete boxes of the size specified by the Code. Reinforcement shall be 3/4 inch mesh No. 20 U.S. gage hardware cloth, or bar reinforcement. Box covers shall be provided with two 3/8 inch brass hold-down bolts with brass washers and nuts. Nuts shall be recessed below the surface of the cover.

31.02 Where pullboxes are to be placed in areas subject to traffic loads, a steel cover of suitable design to withstand such loads shall be used in lieu of the concrete cover.

31.03 Pullboxes shall be installed at the locations shown on the plans, and when runs are more than 200 feet at such additional points as ordered by the Director. The Contractor may install at his own expense, such additional pullboxes that may be desired to facilitate the work.

31.04 The bottom of all pullboxes shall be constructed as shown on the Standard Drawings.

31.05 Pullboxes shall be installed so that the covers are level with the curb, pavement or sidewalk grade, or level with the surrounding ground when no grade is established.

## 32.00 CONTROL AND SWITCHING EQUIPMENT:

32.01 All components within the service box shall be clearly marked with the manufacturer's name and part number with a metallic or permanently marked engraved stencil for future identification.

32.02 All control and switching equipment and fusing of the circuits shall meet the requirements of the National Electrical Code, the Electrical Safety Orders of the Industrial Accident Commission of the State of California, to the rules of the National Board of Fire Underwriters, and to the County of Sacramento, and Sacramento Municipal Utility District ordinances and rules. Wires from photo cell control wires entering from under ground conduits will terminate at a terminal block in the service can.

## 33.00 CONDUCTORS AND CABLE:

33.01 Multiple circuit lighting conductors shall be designed for 600 volts.

33.02 Conductors larger than #8AWG size shall be stranded.

33.03 Conductors shall all be insulated with TW moisture resistant insulation and so stated on the insulation as stamped by the manufacturer.

33.04 Conductors shall be minimum size #10AWG running up the standards.

33.05 Multi-conductor cables shall be used only when specified in the special provisions or approved by the Director. The insulation resistance shall not be less than as specified in the National Electrical Code.

34.00 PAINT:

34.01 Paint for the steel standards and the control installation shall be received on the job in the original sealed container with a certificate from the manufacturer guaranteeing compliance with the following specifications.

34.02 Primers shall conform to the following.

34.02-1 Red Lead Linseed Oil Primer; California State Specifications 52-G-60 and 52-G-61, or Federal Specification 52-G-51.

34.02-2 The final coat shall be W.P. Fuller and Company, Catalog No. 1531, Locker Green Myratic, or equal.

35.00 CONCRETE:

35.01 All concrete shall be Class "A" and in conformance with the Standard Specifications.

36.00 CONDUIT:

36.01 Conduit shall be laid to a depth of not less than 18 inches below the curb grade in sidewalk areas, and to a depth of not less than 24 inches below the finished grade in all other areas. Conduit under railroad tracks shall be not less than 24" below the bottom of the ties.

36.02 When conduit is placed in areas subject to further improvements, such as widening of the street and installation of curbs, gutters, and sidewalks, the conduit must be laid at an elevation established by the Director.

36.03 Conduit shall be placed under existing pavement by approved jacking or drilling methods unless otherwise approved by the Director. Upon approval of the Director, small test holes may be cut in the pavement to locate obstructions. Jacking or drilling pits shall be kept two feet clear of the edge of the pavement wherever possible. Excessive use of water such that pavement might be undermined, or subgrade softened, will not be permitted.

36.04 Conduit stubs from electrolier bases shall extend at least six inches from the face of the foundation, and at least 18 inches below the top of the foundation. Conduit stubs on structures shall be as shown on the plans.

36.05 Conduit terminating in the standards or pedestals shall extend approximately two inches above the foundation, and shall be sloped toward the hand hole opening. Conduit entering concrete pullboxes shall terminate two inches inside the wall of the box and not less than three inches above the bottom, and shall be sloped to facilitate pulling of the cable. Conduit entering through the bottom of a pullbox shall be located near the endwalls to leave the major portion of the box clear. At all outlets, conduit shall enter from the direction of the run.

36.06 Conduit entering controller cabinets shall be sealed with paraffin or other approved sealing compound to prevent the entrance of gases.

36.07 Where ground continuity is required in conduit, bushings shall be cast steel with ceramic insulator and in other locations may be plastic.

36.08 All conduit ends shall be threaded and capped with standard pipe caps until wiring is started. When caps are removed, the threaded ends shall be provided with approved conduit bushings.

36.09 Conduit stubs, caps, and exposed threads shall be painted with an approved rust-preventive paint.

36.10 The location of all conduits in structures, or terminating at curbs, shall be marked by a "Y" at least three inches high cut into the face of curb, gutter, or wall, directly above the conduit.

36.11 Conduit bends, except factory bends, shall be made without crimping or flattening, using the longest radius practicable, but in any case not less than six times the inside diameter of the conduit.

36.12 The ends of all conduits shall be well reamed to remove burrs and rough edges. Field cuts shall be made square and true so that the ends will butt or come together for the full circumference thereof. Slip joints or running threads will not be permitted for coupling conduit. When a standard coupling cannot be used, an approved threaded union coupling shall be used. The threads on all conduit shall be well painted

with a good quality of lead or rust preventive paint before couplings are made up. All couplings shall be screwed up until the ends of the conduits are brought together, so that a good electrical connection will be made throughout the entire length of the conduit run. Where coating on conduit has been injured in handling, or installing, such injured place shall be thoroughly painted with an approved rust preventive paint.

36.13 Where larger than minimum size conduit is used, it shall be for the entire length of the run from outlet to outlet. No reducing couplings will be permitted.

### 37.00 EXCAVATING AND BACKFILLING:

37.01 The excavation required for the installation of conduit, foundation, and other appliances shall be performed in such a manner as to cause the least possible injury to the streets, sidewalks, lawns, and other improvements. The trenches shall not be excavated wider than 6 inches unless written approval is obtained from the Director. Excavation shall not be performed until immediately before installation of conduit and other appliances. The material from the excavation shall be placed in a position where the least damage and obstruction to vehicular and pedestrian traffic and the least interference with the surface drainage will occur.

37.02 Improvements such as plastic street markings, sidewalks, curbs, gutters, Portland cement concrete and asphalt concrete pavement, bituminous surfacing, base material, and any other improvement removed, broken, or damaged by the Contractor shall be replaced or reconstructed to the satisfaction of the Director.

37.03 Unless otherwise approved by the Engineer, the outline of all areas to be removed in concrete sidewalks and in pavements shall be cut a minimum depth of 1½ inches with an abrasive type saw prior to removing the sidewalk and pavement material. Cut for remainder of the required depth may be made with a method satisfactory to the Director. Cuts shall be neat and true with no shatter outside the removal area. Whenever a part of a square or slab or existing concrete sidewalk or driveway is broken or damaged, the entire slab shall be removed and the concrete reconstructed as above specified.



37.04 When heavy machinery is used to dig trenches or boring pits, sufficient planking shall be used to insure the least possible damage to lawns, sidewalks, etc.

37.05 Backfilling shall meet the requirements of the Standard Specifications.

38.00 PAVEMENT REPLACEMENT, CLEAN-UP, PUBLIC CONVENIENCE:

38.01 All applicable requirements of the Standard Specifications shall apply.

39.00 STANDARDS AND STANDARD BASES:

39.01 Standards shall be mounted in a true and vertical position on bases constructed as shown on Standard Drawing L-2. The elevation of the base shall be specified by the Director to conform to the required mounting height of the luminaire without changing the pole height.

39.02 Concrete shall not be placed in the forms until the placing of the reinforcing steel has been approved by the Engineer.

39.03 The top four inches of concrete poured after the pole has been leveled must be formed and finished to a proper grade into a square slab 2' x 2' whether the optional 2' diameter round foundation is used or not.

40.00 WIRING:

40.01 Wiring shall conform to appropriate articles of the National Electrical Code, and the requirements of the Electrical Safety Orders of the Industrial Accident Commission of the State of California; to the rules of the National Board of Fire Underwriters; and to County of Sacramento and Sacramento Municipal Utility District ordinances and rules. Wiring within cabinets, junction boxes, etc. shall be neatly arranged and laced.

40.02 Powdered soapstone, talc, or other approved lubricant shall be used in placing conductors in conduit.

40.03 Conductors shall be jointed by a "Western Union" type splice or by the use of an approved connector. All splices shall be soldered by the pouring or dipping method. Acid flux or other types of flux harmful to the insulation may not be used. Connectors shall be used for splicing all conductors #8AWG or larger. When "Scotchlok" connectors, or equal, are properly used, no soldering shall be required.

40.04 Conductor insulation shall be well penciled, trimmed to conical shape, and roughened before applying splice insulation. Conductors shall be so spliced or joined as to be mechanically and electrically secure without solder and, unless an approved splicing device is used, shall then be soldered with a fusible metal or alloy or brazed or welded. All splices and joints and the free ends of conductor shall be covered with an insulation equivalent to that on the conductors as shown on Standard Specifications Sheet TS-3.

40.05 When conductors and cables have been pulled into the conduit, all ends of the conductors and cables shall be taped to exclude moisture, and shall be so kept until the splices are made or terminal appliances attached. Ends of spare conductors shall remain taped.

40.06 A small permanent band or bands, on which the circuit, designation number, and phase are stamped in the order named, shall be securely attached near the end of each conductor at each controller switch, standard, or pullbox, where the conductors are separated. Where circuit and phase are not clearly indicated by the conductor insulation, additional bands shall be used.

40.07 Direct burial cable may be used from pullbox to pullbox in lieu of metallic conduit, with the written approval of the Director. All cable shall conform to the requirements of the National Electrical Code and other related documents.

#### 41.00 BONDING AND GROUNDING:

41.01 Metallic cable sheaths, conduit, and metal poles shall be made mechanically and electrically secure to form a continuous system, and shall be effectively grounded. Bonding and grounding jumpers shall be copper wire of the same cross-sectional area as #6AWG for all systems.

41.02 Bonding of standards shall be by means of a bonding wire of not less than #6AWG size conductor attached to a brass or bronze anchor bolt of 3/4 inch diameter or larger, installed in the lower portion of the shaft.

41.03 Grounding of conduit and neutral at any service point shall be accomplished as required under the Code, except that grounding conductors shall be #6AWG.

41.04 A ground electrode shall be furnished and installed on each multiple service point. Ground electrodes of steel or iron shall be one-piece lengths of galvanized rod or pipe at least 3/4 inch in diameter. Electrodes should, as far as practicable, be imbedded below permanent moisture level. Except where rock bottom is encountered, rods shall be driven to a depth of at least 8 feet regardless of size or number of electrodes used. Where rock bottom is encountered at a depth of less than 4 feet, electrodes shall be buried in a horizontal trench. Each electrode shall be separated by at least 6 feet from any other electrode, including those used for signal circuits, radio, lightning rods, or any other purpose. The service equipment shall be bonded to the ground electrode by use of a grounding clamp and #6AWG copper wire, or equal, enclosed in a 1/2 inch diameter conduit or hardwood molding.

42.00 POWER SERVICE:

42.01 The location of service points will be determined by the Engineer with the concurrence and approval of the serving utility. The service shall have a minimum height of 20 feet above the ground.

42.02 Conduit for service lines shall not be less than 1½ inches in size.

42.03 Service fittings shall include a two wire or a three wire solid neutral, 120 or 120/240 volt, service circuit breaker or service switch, in a raintight housing together with a safety socket box or meter socket, or both, located as specified by the Director with the concurrence and approval of the serving utility.

42.04 Each service switch or service circuit breaker housing shall be provided with hasp and padlock. All padlocks must be Master #3 keyed to the County master key. Key number will be furnished by the Director upon request.

42.05 The Director will arrange with the serving utility to complete all service connections.

43.00 SANITARY SEWER SYSTEM DESIGN STANDARDS:

43.01 These design criteria shall govern the engineering design of sanitary sewer projects which will be maintained by Sacramento County.

44.00 AVERAGE FLOW DETERMINATION:

44.01 Zoning - Flow determination shall be based upon the most recent zoning. The minimum population density used shall be equivalent to that of single family zoning. The area shall be examined for trends toward population concentration and, if found, an estimate should be made of the probable extent of such concentration. This estimate shall be used as the basis for determining flow.

44.02 Single family and duplex units - Flow shall be based on four persons per residential unit, 100 gallons per person per day, and four lots per acre.

44.03 Commercial and multiple residential - Flows shall be determined from the curves on Standard Drawing No. 910-S-8.

44.04 Schools - The larger flow, as determined from one of the two following methods, shall be used.

44.04-1 The entire school area shall be assumed R-1 zoning with 16 people per acre and 100 gallons per person per day.

44.04-2 Flow shall be based on ultimate design student population plus administration, teaching and operating personnel. Per capita average flow shall be as follows:

Grammar School	40 gallons per day
Jr. & Sr. High School	50 gallons per day

44.05 Industrial - Every attempt should be made to base flows on specific, known industrial development. In the absence of specific knowledge of development, flow shall be determined from the curves on Standard Drawing No. 910-S-8.

45.00 DESIGN FLOW:

45.01 Average flow, as determined above, shall be multiplied by the peaking factor obtained from the curve on Standard Drawing No. 910-S-9 to obtain design flow.

46.00 PIPE SLOPE, VELOCITY AND SIZE:

46.01 Minimum size of laterals which serve single family or duplex development shall be 6 inches in diameter. Schools, commercial, industrial, and multiple residential shall be served by lines 8 inches in diameter, minimum. Single commercial buildings which contribute negligible sewage flow, when among single family or duplex development, may be served by a lateral 6 inches in diameter, minimum. The Director shall be consulted in every such case and his decision shall be final.

46.02 Minimum velocity shall be 2.0 f.p.s. when the pipe is half full or full. Use of lesser velocities shall have the specific approval of the Director. Manning's formula shall be used to determine the relation of slope, design flow, velocity, diameter, and "N" value. The "N" value shall be 0.013 for all pipe materials.

46.02-1 Following is a table of slope vs. diameter when the velocity is 2.0 f.p.s. where the pipe is half full or full.

Diameter, inches	Slope, foot per foot
6	0.005
8	0.0035
10	0.0025
12	0.0020
15	0.0015
18	0.0012

46.03 Pipe capacity, in all cases, shall be adequate to carry design flow from the entire tributary area, even though said area is not within the project boundaries.

47.00 LOCATION AND ALIGNMENT:

47.01 All sanitary sewers shall be placed within rights of way dedicated for public streets unless use of easements is specifically approved by the Director.

47.02 New subdivision - Sewers shall be located 6' south or east of street centerline.

47.03 Existing streets - When sanitary sewers are to be placed in existing streets, factors, such as curbs, gutters, sidewalks, traffic conditions, pavement conditions, future

street improvement plans, and existing utilities shall all be considered; Sacramento County Highways Division and Utilities Division approval shall be obtained in every instance.

47.04 Easements - The minimum width of easements shall be 10 feet. When sanitary sewers are to be installed under a private road, the easement shall be 10 feet in width or the width of the paving plus one foot each side, whichever is greater.

47.05 No sanitary sewer shall be placed nearer than 50 foot to any domestic well unless the well has been abandoned in full accord with Health Department requirements.

47.06 Horizontal alignment - Alignment shall be parallel to the street centerline wherever possible. Minimum radius for sanitary sewers 6 inches through 24 inches in diameter shall be 200 feet. A larger radius shall be used whenever practicable. A manhole shall be placed at any abrupt change in alignment. Changes in alignment of pipe 27 inches in diameter and larger shall be by use of manholes, mitered joints, fittings, or deflected joints as specified in the Sanitary Sewer Section of the Standard Specifications.

47.07 Vertical alignment - Maximum deflection for vertical curves shall be 1/4 inch per foot. A manhole shall be placed at any abrupt change in grade. Elevation shall be shown on the plans at 10 foot intervals throughout the length of the vertical curve.

#### 48.00 TRENCH LOADING:

48.01 Marston's formula shall be used to determine the load placed on the pipe by the backfill. The procedure is described in the ASCE Manual of Engineering Practice No. 37, the Clay Pipe Engineering Handbook, and in similar handbooks. In the absence of specific soils data, as determined by a registered engineer specializing in soil mechanics, a soil weight of 120 p.c.f. and a  $K_u$  factor of 0.130 shall be used.

48.02 A safety factor of 1.25 shall be used for reinforced concrete pipe and a safety factor of 1.5 shall be used for all other pipe. Only the three edge bearing strength of the pipe shall be used in the computations.

48.03 Bedding types and factors shall be as per Standard Drawing 910-S-1 of the Standard Specifications. Bedding type shall be as necessitated by height of cover over the pipe, trench width, pipe strength, and other factors used to determine safe pipe loading.

48.04 Type III and IV bedding (concrete) shall require specific approval of the Director before use. These bedding types are intended primarily for emergency field use and their use shall normally not be specified on the plans.

48.05 Cast iron pipe or epoxy lined asbestos-cement pipe, as approved by the Director shall be used whenever cover is greater than 25 feet or extra support strength is required for pipe in sizes 10 inch diameter and smaller. Cast iron pipe shall be used whenever cover is less than 3 feet.

48.06 A simplified table which relates cover, pipe diameter, trench width, bedding type, etc. according to Marston's formula is on Standard Drawing No. 910-S-10.

#### 49.00 MANHOLES:

49.01 Manholes shall be placed at the intersections of all sanitary sewer lines, unless waived as per Section 52.00 and at the ends of all permanent lines 100 feet or more in length.

49.02 Maximum spacing of manholes shall be 400 feet for all straight lines of 10 inches diameter or less. Manhole spacing on lines which curve continuously between manholes with a radius of 200 feet (minimum) shall be 200 feet. Manhole spacing on curved lines of length of curve and radius less severe shall be adjusted proportionately. Reverse curves will require a manhole at the point of tangency between the curves.

49.03 The average hydraulic grade line of any pipe which flows into a manhole shall be 0.10 foot (minimum) above the average hydraulic grade line of the exit pipe. When the major conduit, based on flow, passes through a manhole with less than 20 degrees deflection, the 0.10 foot differential between hydraulic grade lines will not be required for the major conduit, only. The average hydraulic grade lines shall be derived from design flows based upon 100% development of the tributary areas.

49.03-1 In the absence of calculations which establish the average hydraulic grade lines, the invert of any incoming pipe shall be located not lower than the spring line nor higher than the crown of the exit pipe. The crown of the exit pipe shall never be higher than the crowns of pipes entering the manhole. Exceptions shall be approved by the Director. Drop connections are not governed by the above elevation requirements.

49.04 Manhole construction shall conform with provisions of the Standard Drawing 910-S-2 of the Standard Specifications.

50.00 DROP CONNECTIONS:

50.01 A drop connection shall be required whenever a pipe does not enter a manhole in conformance with Section 49.03. Drop connections shall conform to Standard Drawing 910-S-4 of the Standard Specifications. The inside drop connection shall be used for all 6 inch and 8 inch diameter laterals and outside drop for larger diameter laterals, unless the Director authorizes otherwise.

50.02 Free drops from the incoming lateral to the bottom of the manhole will not be permitted and shall be eliminated by use of a drop connection, vertical curve, or increased slope of the incoming lateral.

51.00 FLUSHING BRANCHES:

51.01 A flushing branch may be used in lieu of a manhole at the end of any line less than 100 feet long. A flushing branch may also be used at the end of a line less than 200 feet long if the line extends to a subdivision boundary and if there are definite plans for extension of the line. If a line extends to a subdivision boundary and is planned for definite extension but does not have house sewers along it, it may be capped. Flushing branches shall conform to Standard Drawing 910-S-3 in the Standard Specifications.

52.00 SERVICE SEWERS:

52.01 Service sewers shall conform to Standard Drawing 910-S-5 of the Standard Specifications. The service sewer shall extend from the lateral sewer to the edge of public right of way or edge of easement. Service sewers shall extend one



foot beyond each edge of pavement of any private road and easements of adequate width to accommodate the services shall be obtained. A plan and profile of any service sewer shall be supplied the Director upon request.

52.02 Normal service sewer size is 4 inches. Schools and other developments expected to contribute high sewage flows shall be served by 6 inch or larger service sewers. In addition, service sewers shall be sized according to requirements of the Plumbing Code, the Utilities Division, and determinations by the Consulting Engineer. A 6 inch service sewer shall enter a 6 inch lateral by means of a manhole but may enter an 8 inch or larger lateral by means of a factory "Y". Eight inch diameter and larger services shall be connected to the lateral by use of a manhole.

52.03 The Utilities Division shall make all service sewer taps into existing laterals upon application for permit and payment of required fees. A note to this effect shall be placed on the plan sheet which requires such tapping.

52.04 Service sewers shall not connect to trunk sewers (12 inch diameter and larger) without the written approval of the Director.

52.05 Unless specifically requested otherwise by the property owner, service sewers shall be placed on the low side of any typical subdivision lot or similar parcel with 2 percent or greater slope across the front or shall be placed in the center of lots of lesser slope. Consideration shall be given to trees, improvements, etc. so as to minimize interference when service sewer is extended to serve house.

52.06 The Consulting Engineer shall verify the adequacy of the normal service sewer depth at the edge of easement or right of way, to serve the intended parcel. A depth of 4 feet from back of existing or proposed sidewalk to crown of pipe shall be considered normal service sewer depth. Whenever greater depth is required, the Consulting Engineer shall designate the invert elevation of the service sewer at the edge of the right of way or easement on the construction plans.

52.07 When sanitary sewers are part of new subdivision construction, a service sewer shall be constructed to each lot.

52.08 In developed areas a service sewer shall be provided each parcel which contains a source of sewage less than 200 feet from a lateral. A property owner's request for service shall be honored whenever practicable. Parcels which have two or more sources of sewage must have an independent service sewer provided each sewage source which can be separated from the rest of the parcel and sold. A service sewer shall be provided each subdivision lot or lot similar as to size and possible development. At an early stage of design, the Consulting Engineer shall send every property owner affected by the proposed work, a questionnaire requesting, in writing, the owner's preferred service sewer location. In absence of a response to this questionnaire, the Consulting Engineer shall provide a service sewer as required by this Section. In addition, when the service sewers are staked immediately prior to construction, each property owner shall be given notice that he should look at the staked location of his service sewer and if not satisfactory, immediately notify the Consulting Engineer. The date of notification by the property owner, method of notification, nature of change, and other pertinent information shall be recorded. Compilation of this information shall be the Consulting Engineer's responsibility and the information shall be furnished the Director upon request.

### 53.00 CREEK CROSSINGS:

53.01 In all cases, the proposed future creek bed elevation shall be used for design purposes. This future elevation shall be obtained from the Drainage Section, Sacramento County Highways Division. Crossing details of pipe, pier, anchorage, transition couplings, etc. shall be shown upon a detail sheet of the plans in large scales.

53.02 For line sizes 10 inches and smaller, cast iron pipe shall be used under the full creek width plus 10 feet each side unless the pipe is 8 feet or more below the creek flow line. For line sizes 12 inches and larger, pipe used shall be as directed by the Engineer. All soft or organic material shall be replaced with select imported backfill and, in

addition, the top two feet of backfill within the creek banks shall be gravel of 3/4" to 1½" size. Special care shall be used to provide a firm base for the pipe bedding. Full concrete encasement may be required.

53.03 If the pipe must cross above the creek bed, aluminum pipe or cement lined and coated welded steel pipe shall be used. The Director may specify which is to be used. Reinforced concrete cylindrical piers of adequate depth shall be used at each end of the span. The pipe shall be held by galvanized steel straps, with galvanized anchor bolts of adequate size, in cylindrical cradles formed in the pier tops. Cushion material shall be placed between the pipe, clamps, and support. The point of maximum deflection of the suspended pipe shall be higher than the invert of the pipe at its downstream support.

53.04 Calculations shall be submitted which clearly indicate the design of the pipe and supports regarding impact, horizontal and vertical forces, overturning, pier and anchorage reactions, etc.

#### 54.00 JACKING - BORING:

54.01 All pipe, except R.C.P. and 4 inch diameter service sewers as per the Standard Specifications, which is jacked and bored shall be placed in a welded steel conductor pipe of sufficient diameter to allow sand backfill to be placed and to allow adjustment of the sanitary sewer pipe to grade. R.C.P. shall be bored directly, placed in a conductor, or placed in tunnel liner. The method used shall be specifically approved by the Director.

#### 55.00 CROSSING CULVERT PIPE:

55.01 When concrete is placed between culvert pipe and sanitary sewer pipe, it shall be insulated from both pipes by building paper. The Consulting Engineer shall check all culvert crossing with the Drainage Section, Sacramento County Highways and Bridges Division, to determine if future changes in culvert size or location are anticipated.

#### 56.00 PUMP STATIONS - FORCE MAINS:

56.01 Every phase of pump station design, including force mains, shall be closely coordinated with and shall be under the direction of Sacramento County Utilities Division.

57.00 PREPARATION OF PLANS:

57.01 A preliminary design for each sanitary sewer project proposed to be constructed in Sacramento County shall be submitted to, and be approved by, the Director prior to submission of project construction plans.

57.02 The preliminary design shall be submitted in the form of a map and table. The map shall show the following:

- a. Area of project.
- b. Tributary areas outside project.
- c. Adjacent areas.
- d. Contours over complete map.
- e. Line layout and pipe size.
- f. Predicted average and peak flows at major junction points, including flow coming from outside the project area.
- g. Direction of flow.
- h. Zoning used to predict flows.
- i. Special areas such as hospitals, schools, large office buildings, etc.
- j. Boundaries of areas within the project which are tributary to points of major flow.
- k. Scale.

The table shall include the following in tabular form:

- a. Areas tributary to points of major flow.
- b. Zoning within each area.
- c. Predicted flow from each area.
- d. Peaking factors.
- e. Cumulative flow.
- f. Pipe size and slope.

57.03 A parcel or area which benefits and participates in a project, but is not included within the project boundaries shall have a note to this effect placed on the overall project map and on the plan and profile sheet if the parcel appears thereon. Parcels not so noted which make use of a project's facilities after the project's completion will be required to pay an "in-lieu fee" prior to such use.

57.04 The complete plans shall consist of the cover sheet, layout sheet, plan and profile sheets, detail sheets, reference to the Standard Specifications, Special Provisions, etc. The plans shall be assembled in the above order. Each sheet shall be numbered also indicating on each the total number of sheets. The cover sheet shall be No. 1.

57.05 Cover Sheet - The cover sheet shall contain the following items:

57.05-1 Names, titles, C.E. numbers, and signatures of the following:

- a. District Engineer (Director of Public Works) required for all assessment district proceedings, County projects, and District projects.
- b. Utilities Division (Division Chief).
- c. Highways and Bridges Division (Division Chief).
- d. Consulting Engineer (responsible registered engineer).

57.05-2 Signatures of the following shall appear on each sheet of the plans:

- a. Consulting Engineer (responsible registered engineer and C.E. number).
- b. Consulting Engineer (project engineer).
- c. Utilities Division (initials only).

57.05-3 General Notes - The following information is to be included in the general notes:

- a. Datum information.
- b. Depth of underground utilities unknown.
- c. No utility services shown; contractor responsible for determining exact location in field.
- d. Manhole flush with finish grade unless otherwise noted.
- e. Stationing along street centerline unless otherwise noted.
- f. Time of completion.
- g. Special sequence of construction.
- h. Reference to Standard Specifications.

- i. Drafting symbol legend.
- j. Trench bedding to be Type I and trench width at top of pipe unlimited unless otherwise shown.
- k. Clearances shown are from construction centerline to the nearest surface of object noted.

57.06 Layout sheet - The layout sheet shall contain the following information:

- a. Overall map of the project which shows all boundaries, sewer lines, manholes, flushing branches, and other important items of the work.
- b. Contours shall be shown with an interval of 5 feet for relatively flat land and 10 feet of hilly land.
- c. Adjacent sewer facilities, including lateral sewers, identification, etc. shall be shown.
- d. Scale shall be 1" = 100, 200 or 300 feet.
- e. The existing pavement type and condition shall be indicated on the layout sheet. Pavement replacement type and location shall also be indicated. Pavement replacement may be shown on the pertinent plan sheets as an alternate method.
- f. Pipe size shall be indicated.
- g. Flow quantity shall be shown at all significant locations.
- h. Direction of flow shall be shown on each reach of line.
- i. Unsewered areas within the project boundaries which cannot be served at a future date by extension of the project's gravity system shall be indicated.

57.07 Plan and Profile Sheets

57.07-1 The sewer lines to be constructed shall be indicated on the profile by parallel lines spaced the pipe diameter or by a single heavy line at the pipe invert for 10 inch diameter and smaller lines only. Manholes shall also be indicated by parallel lines spaced according to scale or by a single, heavy vertical line if the sewer profile is also shown as a single line. Slope shall be printed 1/8 inch above and preferably parallel to the pipe line. The length, size and type of pipe between each manhole shall be printed parallel to the horizontal grid lines and approximately halfway between the ground surface and pipe line. All pipe inverts at manholes and other structures shall be indicated on the profile. The invert

elevations shall be printed parallel to the horizontal grid lines and shall be underlined by a line which then runs at a 45 degree angle to the corresponding pipe invert.

57.07-2 The location of each service sewer proposed to be constructed shall be indicated on the plans by stationing or by reference to a permanent, well-defined structure. The invert elevation of the service sewer at the property line shall be indicated on the plans whenever the standard depth is inadequate to serve the property. Improvements or lots shown on a plan sheet but served to a line shown on another plan sheet shall have the service shown by a small triangle and letter "S"

57.07-3 Both permanent and working easements shall be shown to scale on the plans. Easement dimensions shall be given and each easement shall be tied to both the property line and the sewer line. Each permanent easement shown on the plans shall be identified by a box or table, on the same plan sheet, which gives the property owner's name and has spaces for the book and page number in which the easement is to be recorded. The Consulting Engineer shall provide the book and page number whenever possible.

57.07-4 The proposed sewer line shall be shown on each plan sheet as a solid line. Sufficient dimensions from street centerline shall be given. If the sewer is to be located in an easement, sufficient dimensions to locate the line in the field shall be shown on the plans.

57.07-5 Gas, water, storm sewers and all other main utility lines above or below ground shall be determined and shown upon the plans with accuracy as great as practicable. The location of any utility line which is parallel to and within 5 feet of the sewer line or which crosses the sewer line at an angle of 30 degrees or less shall be determined with an accuracy of  $\pm 1.0$  foot and the clearance shown upon the plans. Service lines such as water and gas normally shall not be shown.

57.07-6 Trees and other objects within 10 feet of construction centerline shall have their correct location shown on the plans and the clearance from construction centerline shown. The diameter of tree trunks and interfering heavy tree branches shall be noted. Removal of a tree or object, or other special handling shall be noted on the plans. The Consulting Engineer shall assume full responsibility for such notes as it is assumed that the Consulting Engineer has made all necessary arrangements with the owner of the object to be handled. Tree removal within public rights of way must be approved by the Director.

57.07-7 Culverts shall be shown on both plan and profile when crossed by the construction and shall be shown when parallel and within 20 feet of the construction line. The size and type of all such culverts shall be indicated and when the culvert crosses or is perpendicular or nearly so to the construction line, the invert of the culvert nearest the construction line shall be shown.

57.07-8 Driveways, curbs, sidewalks, pavement edges, buildings and all other items which could influence the work shall be shown. Only the front line and indication on the side lines of buildings need be shown.

57.07-9 Addresses of buildings shall be shown on the plan view, within the outline of the building.

57.07-10 Manhole identification on the plan may be oblique and slope designation shall be parallel to the pipe as shown on the profile. Manhole stationing shall appear at the lower edge of the grid directly under the manhole.

57.07-11 Each revision and its date shall be indicated on the pertinent sheet.

57.07-12 The project name and district name shall appear on each sheet of the plans.



57.07-13 Lettering shall be parallel to and read from the bottom or right edge of the sheet. Manhole identification on the plan may be oblique and slope design shall be parallel to the pipe as shown on the profile.

57.07-14 Indicate the limiting maximum trench width, as measured at the top of the pipe, on the plans between well defined points of application; the pipe material and class if more than one class is available; and the bedding-backfill type. Type I bedding, when used, and unlimited trench width, when allowed, need not be shown on the plans. If more than one combination of pipe class, maximum limiting trench width, or bedding type is available, a practical range of such combinations shall be shown on the plans.

57.08 Detail Sheet - Items of special nature, such as creek crossings, and shallow manholes, which are not detailed in the Standard Drawings shall be shown in large scale upon a separate sheet of plans labeled "Detail Sheet". This detail sheet shall be bound immediately after the plan and profile sheets.

57.09 Specifications - The current Standard Specifications shall be made part of the contract documents by a note of reference which shall appear in the Notice to Contractors and in the General Notes of the plans as required in Section 3.02. The technical part of the special provisions, including time of completion and special sequence of construction, shall occur in the General Notes of the plans, or, where specific, on the plan sheet to which they apply. The special provisions may also be printed on plan-size sheets and be bound at the rear of the plans. The wage scale, time of completion, and incidental expenses shall be included in the Notice to Contractors. The Notice to Contractors, Designation of Subcontractors, State of Experience, and Proposal, shall be fastened together and made available to the bidders along with the plans.

## DOMESTIC WATER SYSTEM DESIGN STANDARDS

### 58.00 INTRODUCTION:

58.01 These design criteria shall govern the engineering design of domestic water systems which will be maintained by the Sacramento County Utilities Division.

58.02 The intent of these criteria is to provide a water system that will dependably and safely convey the required amount of high quality water throughout the distribution system with the least cost. In establishing the required amount of water, periods of peak domestic demand occurring in conjunction with an emergency fire flow demand shall be considered.

58.03 Pertinent and current requirements of the following agencies or standards shall be complied with. In case of conflict, the design criteria of the County of Sacramento, as established herein, shall govern.

58.03-1 United States Public Health Service Drinking Water Standards.

58.03-2 Laws and Standards of the State of California, Department of Public Health, Relating to Domestic Water Supply, and particularly therein the Standards of Minimum Requirements for Safe Practice in the Production and Delivery of Water for Domestic Use, as approved by the California Section of American Water Works Association.

58.03-3 Standard Specifications of the County of Sacramento, Department of Public Works.

58.03-4 General Order No. 103 of the California Public Utilities Commission.

58.03-5 Ordinance No. 508 of the County of Sacramento, regulating the installation, operation, construction, reconstruction, and repair of wells and pumps.

58.03-6 Title 17, Chapter V, Sections 7583-7622, California Administrative Code, regarding cross-connections.

58.03-7 National Board of Fire Underwriters' "Standard Schedule for Grading Cities and Towns of the United States", including bulletins and amendments thereto.

59.00 SUPPLY REQUIREMENTS:

59.01 Quality - The quality of the water shall conform to Sections 3 and 4 of the current United States Public Health Service Drinking Water Standards.

59.02 Pressure - Normal operating pressures of not less than 35 p.s.i. nor more than 100 p.s.i. shall be maintained at service connections to the distribution system, except that during periods of peak domestic and fire demand the pressure shall not be less than 20 p.s.i.

59.03 Rate of Domestic Use - For design of the distribution system, a peak domestic demand rate of fifteen gallons per minute per gross acre shall be assumed. For extension of existing systems consisting of more than 500 services, the design shall be based on records of the average rate of consumption per service on the day of maximum use. Special consideration shall be given to areas zoned for multiple housing, schools, commercial, or industrial development. Storage reservoirs shall be considered in meeting these requirements.

59.04 Required Fire Flows - For areas of the general types noted below, the indicated fire flows are to be provided with the initial development. Expansion or change in zoning of the development shall be subject to National Board of Fire Underwriters' requirements.

59.04-1 Residential Area - For residential areas having primarily one story single family dwellings, on average size lots, provide a minimum 750 gallons per minute.

59.04-2 Commercial and Multiple Dwelling Areas - For closely built areas containing apartments and light commercial structures, provide 1500 to 2000 gallons per minute.

59.04-3 Principal Business Districts - Consult the "Standard Schedule for Grading Cities and Towns of the United States" by the National Board of Fire Underwriters.

59.04-4 Other - For industrial and other individual high value buildings, fire flow requirements shall be established as prescribed in Bulletin No. 266, "Water Works Requirements for Fire Protection", of the National Board of Fire Underwriters.

59.05 Well and Pumping Plant Design - All phases of well and pumping plant design shall be closely coordinated with and shall be under the direction of Sacramento County Utilities Division. Particular attention shall be given, both in design and construction, to conformance with Ordinance No. 508 of the County of Sacramento.

59.05-1 In no case, regardless of size of initial development, shall a single well system be accepted, unless adequate elevated or ground-level storage facilities are provided. The design yield of wells shall be limited to 1000 gallons per minute.

59.05-2 Care shall be exercised in the selection of a well site. No site shall be considered that will result in pumping equipment being within fifty feet of an existing or proposed structure or within 100 feet of an existing or proposed sanitary sewer.

59.06 Distribution System Design - Sizing of mains shall be such that the pressures specified in paragraph 59.02 are maintained. The minimum requirements for main spacing and sizing shall be as called for in Section 60.02.

59.06-1 The Hazen-Williams formula shall be used in the hydraulic study of the system, using a "C" value of 130 for asbestos cement and cement lined pipe. A Hardy-Cross hydraulic analysis of any proposed distribution system shall be supplied the Utilities Division upon request. In design of the system, the maximum delivery from any hydrant of a type conforming to current County Standard Specifications shall be assumed to be limited to 1500 gallons per minute.

## 60.00 DISTRIBUTION SYSTEM REQUIREMENTS:

60.01 Main Location - All water main shall be installed within a five foot easement immediately adjacent to and behind property line fronting on public streets or roads. If it should be necessary because of existing improvements to locate the main within the pavement of a public street or road, the preferable location shall be three feet from the curb and gutter on the northerly or westerly side of the street. In every instance where main is to be installed in public streets or roads, the Sacramento County Highways Division shall be consulted for preferred location and Utilities Division approval obtained.

60.01-1 If it is necessary to install a water main within a private road, the easement shall be the width of the paving plus one foot each side.

60.01-2 Five feet shall be the minimum horizontal distance between parallel water and sanitary sewer lines and the water main shall be installed at least twelve inches higher than the sewer. The only exception to this spacing requirement is the situation wherein a water service is installed on a bench above and offset from the sewer service, as shown on Standard Drawing No. 913-W-1 of the Standard Specifications of the County of Sacramento, Department of Public Works, as adopted June 14, 1965.

60.01-3 When crossing a sanitary sewer force main, it shall be specified that the water main be installed a minimum of two feet above the sewer line and be of cast-iron or, if asbestos cement, be encased in Class "B" concrete, in either case extending at least five feet on each side of the force main.

60.02 Main Layout and Sizing - The distribution system, whenever possible, shall be in grid form so that pressures throughout the system tend to become equalized under varying rates and locations of maximum demand. The minimum pressures and flows as specified in Section 59.02 shall govern design of the system. The following conditions are to be considered for the minimum size pipe.

60.02-1 In general, the minimum pipe size shall not be less than six inches inside diameter. The installation of four inch mains shall be limited to cul-de-sacs or courts where the length of the pipeline is 300 feet or less, or as indicated under dual mains, below.

60.02-2 Dual mains (one pipeline on each side of the street) shall be installed in streets which carry heavy concentrations of traffic, or the rights of way which are 80 feet or more in width. State highways and County major thoroughfares generally are in this category. In those streets classified for dual mains, the minimum size shall be six inch on each side in residential areas, except that one of them may be four inches in diameter where the distance between intersecting lines is not greater than 600 feet. In commercial districts the sizes shall be not less than one eight-inch and one six-inch.

60.02-3 The distribution system shall be gridironed with eight inch or larger cross connecting mains at intervals of approximately 1300 feet, with intermediate six inch lines as required.

60.02-4 Larger mains shall be provided at one mile intervals or to serve multiple housing, commercial or industrial areas as determined by an engineering evaluation of the anticipated demand.

60.03 Valves, Hydrants, and Blow-offs - The distribution system shall be equipped with a sufficient number of valves so that no single shut down will result in shutting down a transmission main, or necessitate the removal from service of a length of pipe greater than 500 feet in school, commercial, industrial, or multiple family dwelling areas or greater than 800 feet in other districts. In no case shall more than two fire hydrants be removed from service. The valves shall be so located that any section of main can be shut down without going to more than three locations to close valves. Valves shall preferably be located at street intersections, three feet into the pavement from the curb and gutter where possible. If it is necessary to install valves between street intersections, they shall be located on property lines between lots.

60.03-1 Fire hydrants shall be placed at street intersections wherever possible, and located to minimize the hazard of damage by traffic. They shall have a maximum normal spacing of 500 feet measured along the street frontage. Hydrants located at intersections shall be installed at the curb return. All others shall be located on property line between lots.

60.03-2 Not more than two hydrants shall be placed on a six inch main between intersecting lines, and not more than three hydrants on an eight inch main between intersecting lines. The minimum size main serving a fire hydrant shall be not less than six inches in diameter. The pipeline connecting the hydrant and the main shall be six inch, with a gate valve installed near the main.

60.03-3 A blow-off assembly shall be installed on all permanent dead-end runs. Special attention shall be given to those of a temporary nature, taking into consideration the length of the dead-end run, the number of services on the line and the estimated time before extension. Wherever possible, the blow-off shall be installed in the street right of way, three feet from the curb and gutter. In no case shall the location be such that there is a possibility of back-siphonage into the distribution system.

60.04 Service Lines - Service lines from the water main to the property line or edge of easement shall normally be installed at the time the main is constructed. Services from mains installed in private roads shall extend one foot beyond the edge of the pavement.

60.04-1 In all new subdivisions, the service line shall preferably be located near the center of the lot to be served. If it is preferred to have the service located other than near the center, it shall be brought in no closer than nine inches to a side property line. The service line to existing buildings shall be located so as to make the most direct connection to the existing structure.

60.04-2 Normal size of a service line shall be one inch. Schools, commercial, industrial, or multiple family units with higher demand shall be provided with larger service lines, subject to approval of the Utilities Division. Service lines in sizes up to and including two inches in diameter shall be copper water tubing; material for lines larger than two inches shall be subject to Utilities Division approval. All services shall be installed with a corporation stop at the main and a curb stop or gate valve at the property line. The gate valve may be used only when the service is  $1\frac{1}{2}$  inches or larger and its use requires installation of a valve box.

60.04-3 The Utilities Division shall make all water service taps into existing mains upon application for a permit and payment of required fees. A note to this effect shall be placed on the plan sheet which details the area that requires such tapping.



CONSTRUCTION CONTRACT DRAWING AND SPECIFICATION  
ELECTRICAL CHECK LIST

1. Location and style of electrical power metering.
2. Service voltage, number of and size and type of drop wires.
3. Location and details of service pole, Floodlighting as required on pole.
4. Location of serving public utility power pole from which lines are to be extended for service.
5. Provision for telephone or future telephone installation. (Items 1 through 5 should be coordinated with representatives of utilities involved.)
6. Conduit sizes, wire size, number of wires, and conduit run locations
  - a. Electric service.
  - b. Pump motor/motors and L. O. S. push buttons.
  - c. Float operated switches.
  - d. Convenience outlets and lights for indoor control installation.
  - e. Telephone service.
  - f. Trash rack high water alarm switch.
  - g. Notation for yard run concrete encased conduit if required.
  - h. Stub outs for future equipment.
7. Location, mounting details, dial calibrations and switch settings for float operated switches.
8. Motors shall not be loaded beyond their nameplate rated horsepower for any condition of pumping. Insulation shall be epoxy varnish vacuum impregnated or encapsulated for random wound and "Silastic" for form wound coils for electrical water proofing. Interior metal surfaces shall be finished in water proof corrosion resistant finish. Motors 60 through 100 H. P. should be specified (440 V. A. C.) as star connected for two part winding starting.
9. Location, type , and mounting of lighting fixtures and receptacles (indoor control installation).
10. Location and mounting details of trash rack high water alarm switch.
11. Location and size of Armco type metal building to house electrical controls. Building shall be painted with one coat of pretreatment vinyl wash primer (State Specification 52-G-52), followed by one coat of Inertol Quick Drying 626 primer or equal, followed by two coats of Inertol Glamortex, Enamel Ivory #312 or equal. Building of sufficient size to give working space as required by the California State "Electrical Safety Orders".

IDENTIFICATION LIST FOR  
DRAWINGS E-1 THROUGH E-5

1. Watt hour meter and meter transformer sections.
2. Main disconnect, circuit breaker, 600 V. A.C., 3 pole Westinghouse A-B "De-Ion," or equal, frame & trip size as required.\*
3. Lighting and miscellaneous power, circuit breaker, 480 V. A.C. EH Frame, 15A./2P. Westinghouse Type A-B.
4. 4 circuit (minimum) 3-15A/1P and 1-20A/1P, 120/240 V. A.C. 3 wire, grounded neutral, lighting circuit breaker panel. (Additional circuits may be required.)
5. Lighting and miscellaneous power transformer, 1.5KVA (minimum) single phase 480/120-240 V. A.C., 60 cycle temperature rise not to exceed 60° C., Class B or better insulation.
6. Circuit breaker, combination part winding starter with control transformer, heavy duty oil tight hand-off-auto. Selector switch, extra time delay relay and control circuit indicating fuse holder, hour meter, with thermostat and heater, wired in accordance with drawing E-11.
7. (Two unit installation only) selector switch. See Drawing E-14. Heavy duty oil tight two position "Lead Pump Selector."
8. Power service conduit rise space.\*
9. Terminal board space and conduit space.\*
10. Telephone terminal box, with two pole terminal board, see Drawing E-15.\* Locate to conform with telephone company requirements.
11. Telephone service conduit 3/4".\*
12. Two-inch high raised concrete pad. Two-inches beyond control center in each direction.\*

\*See Construction Contract Drawings.

## IDENTIFICATION LIST FOR DRAWING E-6

1. Main disconnect, circuit breaker NEMA 1 enclosure 480 V. A.C., E Frame, Westinghouse A-B "De-Ion" or equal (trip size as required\*) 3 pole and SN.\*
2. 4 circuit (\*minimum) 3-15/1P and 1-20A/1P, 120/240V. A.C. 3 wire grounded neutral, surface mounted general purpose enclosure, lighting circuit breaker panel (\*additional circuits may be required).
3. Circuit breaker combination starter, with control transformer, control circuit fuse, time delay relay, and heavy duty oil tight hand-off-auto. selector switch, wired in accordance with Drawing E-13, in N.E.M.A. 1 gasketed enclosure with space heaters and thermostat.
4. Duplex convenience outlet, grounding, 120 V. A.C. 15A, Hubble 5252, or equal.
5. Running time meters, conduit mtg. general purpose enclosure, 120 V. A.C., 60 cycle, 0-10,000 hrs. non-reset, G.E. Co. type 8KT or equal.
6. Lead pump selector switch, two position, 4 pole double throw with escutcheon labeled "1" - "2" oil tight operator and enclosure complete with laminated phenolic nameplate, see drawing E-14.
7. Telephone terminal box with two pole terminal. Board see Drawing E-15.
8. Oil tight wiring gutter, J.T.C. Std.
9. Mounting board, 3/4" Douglas Fir, exterior grade Plywood, primed no coat, and finished two coats grey enamel, fastened securely to building structural members of stiffeners with minimum of 6-3/8" galvanized bolts.
10. Conduit to power meter on service pole.\*
11. Conduit to telephone service entrance 3/4" minimum.\*
12. Conduit to pump motors and heavy duty oil tight lockout stop push buttons.\*
13. Conduit to indoor light and switch.\*
14. Conduit to external lights, switches and receipts. As required.\*
15. Conduit to float operated switches (Drawings E-13 through E-15).\*
16. Conduit to trash rack high water alarm switch.\*

\*See Construction Contract Drawings

## IDENTIFICATION LIST FOR DRAWING E-7

1. Service pole - See Section 6-11 of the County Specifications.\*
2. Power service conduit riser.\*
3. Floodlighting conduit riser.\*
4. Power meter "A" base meter in NEMA 3R enclosure with viewing port - see Section 6-11 of the County Specifications.
5. Main disconnect, circuit breaker, 600 V. A.C. 3 pole Westinghouse A-B "De-Ion" or equal, NEMA 3R enclosure frame and trip size as required.\*
6. Lighting and miscellaneous power transformer, circuit breaker, 480 V. A.C. 2 pole 15A, Eh Frame, Westinghouse A-B "De-Ion" or equal, in NEMA 3R enclosure.
7. Circuit breaker combination starter in NEMA 3R enclosure, with control transformer, hand-off-auto selector switch, control circuit fuse, time delay relay, internal mounted 0-10,000 hr. running time meter line starter wired per drawing E-12 for 30 through 50 H.P. units, and part winding starter wired per drawing E-11 for 60 through 100 H.P. units with space heater and thermostat.
8. Grounding type, duplex convenience outlet, 120 V. A.C. 15 A. in cast weatherproof enclosure.
- 8a. Floodlighting switch, cast weatherproof enclosure.\*
9. NEMA-3R enclosure, housing for 480/120-240, 1.5 KVA Transformer and 4 circuit 120-240 V. A.C. lighting circuit breaker panel (3 wire grounded neutral with 3-15A-1P and 1-20A-1P breakers, 2 are spare).
10. NEMA 4 cast junction box with union hubs as required.
11. NEMA 4 cast telephone junction box with two pole term. Block. See Drawing E-15.\*
12. Equipment mounting backboard assembly, 2" x 6" T & G. Construction grade Douglas Fir planks secured to items 1 and 12a with two 24d common galv. nails @ each end. Backboard planks to be primed prior to assembly and finished with two coats grey enamel prior to mounting of equipment.
- 12a. 6" x 6" construction grade, heart redwood, paint compatible preservative treated, minimum 5 ft. in ground.
13. Grounding system rigid conduit, clamp and 5/8" copperclad rod ground rod driven minimum 6 ft. in ground.
14. Concrete pad minimum 6" thick, slope to drain extend minimum of 4 ft. in front of control assembly and full width, reinforced with No. 4 bars 8" O.C. each way.
15. Conduit underground to pump.\*
16. Conduit underground to float operated switches.\*
17. Conduit as required to telephone service.\*
18. Union connections for conduit as required to make up assembly.
19. Conduit to trash rack high water alarm switch.\*

\*See Construction Contract Drawings

## IDENTIFICATION LIST FOR DRAWING E-8

1. Through 3., similar Drawing E-7.
4. Power Meter, NEMA 3R enclosure.\*
5. Main disconnect circuit breaker, 480 V. A.C., 3 pole and sn. Westinghouse A-B "De-Ion" or equal, NEMA 3R enclosure, frame and trip size as required.
7. Circuit breaker combination line starter in NEMA-3R enclosure, with control transformer, hand-off-auto selector switch control circuit fuse, time delay relay, internally mounted 0-10,000 hr. running time meter, wired per drawing E-12, with space heater and thermostat.
8. and 8a. Similar Drawing E-7.
9. Lighting circuit breaker panel in NEMA 3R enclosure 120-240 V. A.C., 3 wired, grounded neutral, 3-15A-1P breakers and 1-20A-1P breaker (two spares.)
10. and 11. Similar to Drawing E-7.
12. Douglas Fir exterior grade 3/4" Plywood.
- 12a. Through 19. Similar to Drawing E-7.

## IDENTIFICATION LIST FOR DRAWING E-9

1. Service pole see Section 6-11 of the County Specifications.\*
2. Power Service Conduit Riser.\*
3. Floodlighting Conduit Riser.\*
4. Power meter, NEMA 3R enclosure.
5. Main disconnect, circuit breaker, 480 V. A.C. 3 pole & SN, Westinghouse Company A-B "De-Ion" or equal, NEMA 3R enclosure, frame and trip size as required.\*
6. Weatherproof gutter with raintight hubs.
7. Lighting circuit breaker panel in NEMA 3R enclosure 120/240 V. A.C. 3 wired grounded neutral, 4 circuits, 3-15A-1P and 1-20A-1P breaker.
8. Floodlight switch, weatherproof cast enclosure.
- 8a. Duplex, grounding, convenience outlet, 120 V. A.C. 15A., in weatherproof cast enclosure.
9. Heavy duty oil tight selector switch, "lead pump selector switch" with Escutcheon labeled "1" - "2", see Drawing E-14.
10. Circuit breaker combination linestarters in NEMA 3/4 enclosures with control transformer, control circuit fuse, time delay relay, internally mounted 0-10,000 hr. running time meters wired per Drawing E-12, with space heaters and thermostat.
11. NEMA 4, cast telephone junction box with 2 pole terminal block. See Drawing E-15.
12. Backboard for equipment mounting, 3/4" exterior grade Douglas Fir Plywood with 2" x 4" rear horizontal (top and bottom) stiffeners (construction grade). Prime and finish with two coats exterior grey enamel prior to mounting. Board to be secured to stiffeners and Item 1 and 12a using 16d galv. common nails 6" O.C.
- 12a. 6" x6" const. grade heart Redwood, paint compatible preservative treated, minimum 5 ft. in ground.
13. Grounding system rigid conduit, clamp and 5/8" copper clad rod driven minimum 6 ft. in ground.
14. Concrete pad, 6" min. thickness, slope to drain, extend a min. of 4 ft. in front of control assembly and full width, reinforced with No. 4 bars 8" O.C. each way.
15. Conduit underground to float operated switches.\*
16. Conduit underground to pump motors.\*
17. Conduit to telephone service.\*
18. Conduit underground to trash rack high water alarm switch.\*

\*See Construction Contract Drawings.

## IDENTIFICATION LIST FOR DRAWING E-10

1. Main disconnect, circuit breaker 3 pole, 600 V. A.C. Westinghouse Co. type A-B "De-Ion" or equal, frame and trip size as required.\*
2. Lighting and miscellaneous power circuit breaker, 2 pole, 480 V. A.C. Westinghouse Co. type A-B "De-Ion" or equal, "E" frame 15A trip (not required for 240 V. A.C. 3 phase, 4 wire installation\*).
3. Lighting and miscellaneous power transformer, 1.5KVA, 480/120-240 V. A.C. single phase, temperature rise not to exceed 60°C. (Not required for 240 V. A.C. 3 phase, 4 wire installations\*).
4. Lighting circuit breaker panel, 4 circuits 120/240 V. A.C. 3 wire grounded neutral, 3-15A-1P and 1-20A-1P breakers.
5. Lead pump selector switch, heavy duty oil tight, two position, with Escutcheon labeled "1" - "2" see Drawing E-14 (not required on 3 unit installations).\*
6. Weatherproof switch in cast enclosure for area lighting mounted on service pole.
7. Weatherproof duplex grounding type 120 V. A.C., 15A., convenience outlet in cast enclosure.
8. Circuit breaker combination starters (as required\*) with control transformers, control circuit fuse, time delay relays, running time meters 0-10,000 hrs., 7-1/2 through 50 H.P. units wired as line starters per Drawing E-12, and 60 through 100 H.P. units wired as two part winding starters per Drawing E-11 with space heaters and thermostats.
9. Cast weatherproof telephone junction box with two pole terminal block.
10. Conduit underground to telephone service drop 3/4".\*
11. Conduit underground to power metering equipment on service pole (provide panel service race way).\*
12. Conduit underground to area lighting, pump motors, float operated switches and trash rack alarm switch as required.\*
13. Concrete pad 6" minimum thickness, extend 1 ft. beyond panel rear and sides, 3 ft. in front. Reinforcing to be No. 4 bars 8" O.C. each way. Slope to drain.
14. 2" high panel concrete subbase, extend 2" beyond panel on all four sides.

\*See Construction Contract Drawings.

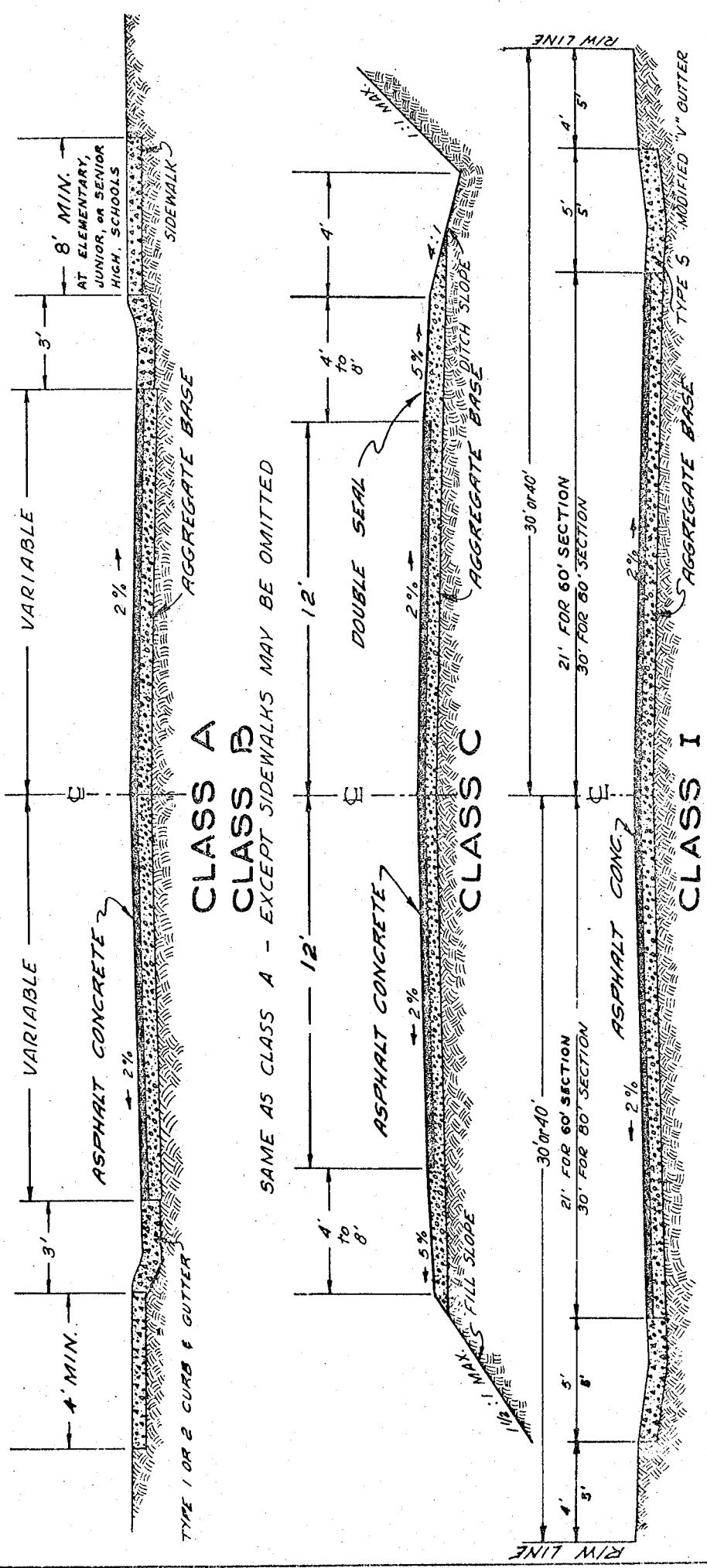

NOTE: AGGREGATE SUBBASE MAY BE REQUIRED IN STRUCTURAL SECTION

SACRAMENTO COUNTY DEPARTMENT OF PUBLIC WORKS HIGHWAY & BRIDGE DIVISION	
TYPICAL SECTIONS	
STREET CLASSES A, B, C & I	
Scale: NONE	Drawn By: A-I
Date: 1-1-60	

APPROVED: *A. R. Kiefer*  
 DIRECTOR OF PUBLIC WORKS

REVISED 7-25-61 A.J.B.



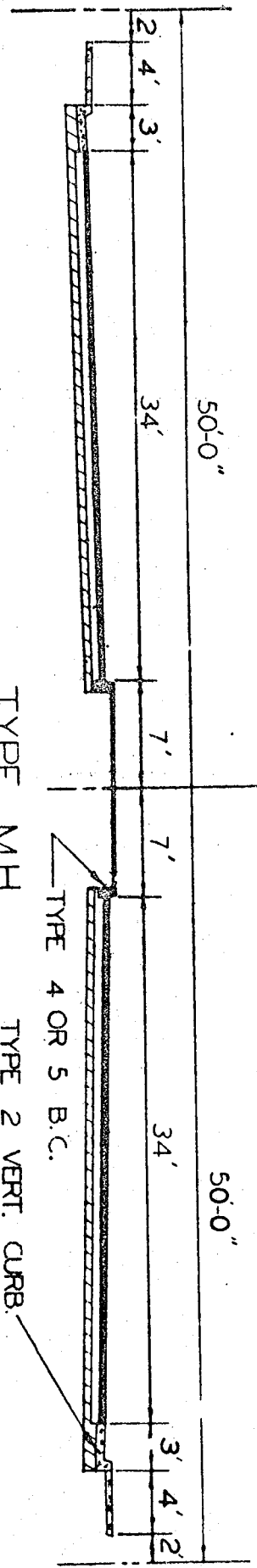
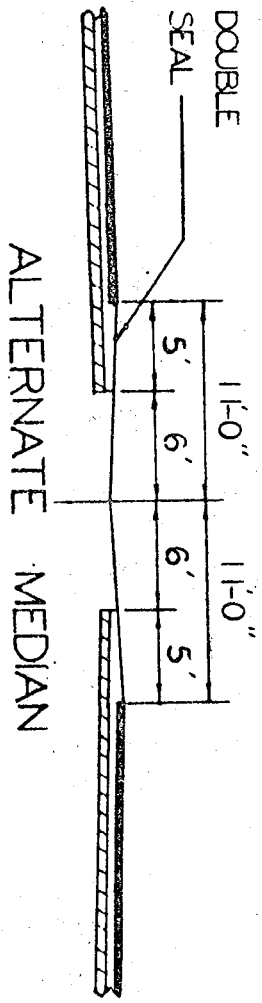

40', 50' OR 55' TO CENTERLINE  
 DEPENDING ON ADJACENT  
 STREET WIDTH

MAJOR HIGHWAY  
 100' RW SHOWN

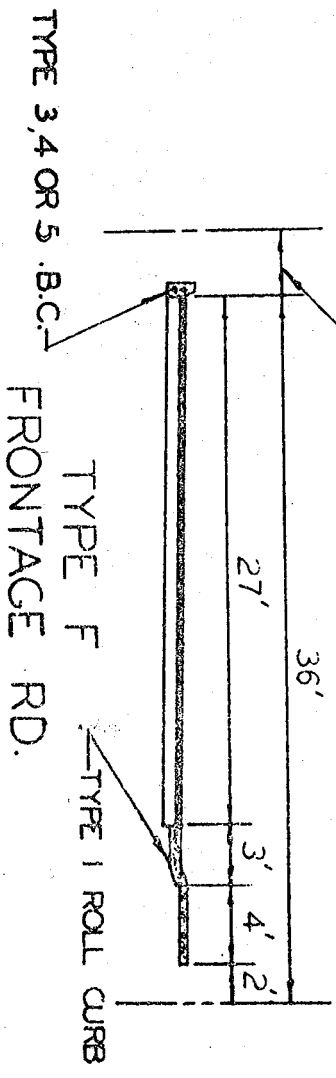

APPROVED: *[Signature]*  
 DIRECTOR OF PUBLIC WORKS

SACRAMENTO COUNTY DEPARTMENT OF PUBLIC WORKS HIGHWAY & BRIDGE DIVISION	
TYPICAL SECTIONS STREET TYPES M.H. & F.	Scale: NONE Date: APRIL 1, 1965 Drawn By:
A-2	

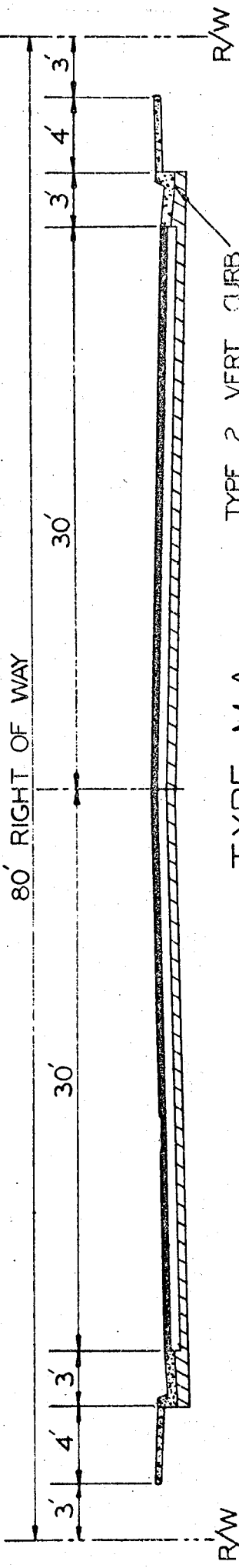

TYPE M.A.  
MAJOR ARTERIAL

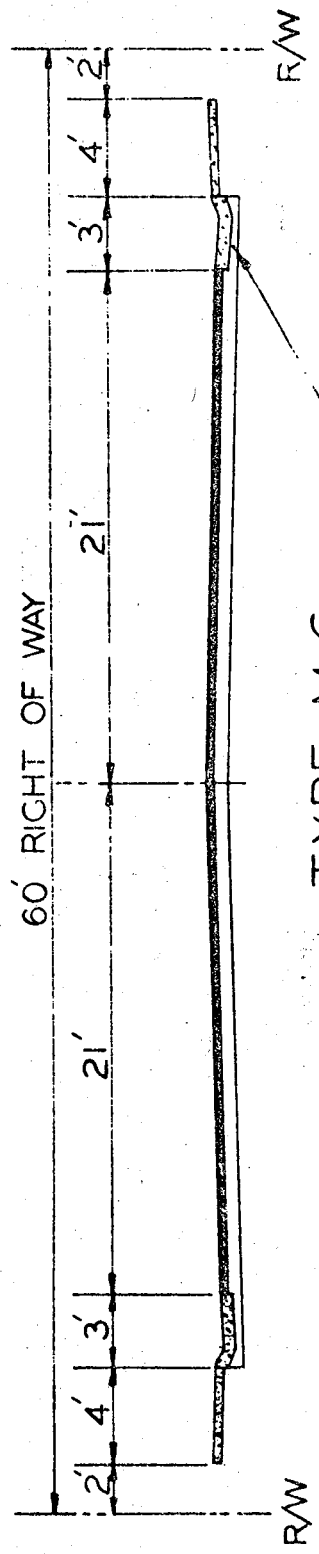

TYPE M.C.  
MINOR COMMERCIAL

SACRAMENTO COUNTY DEPARTMENT OF PUBLIC WORKS HIGHWAY & BRIDGE DIVISION	
TYPICAL SECTIONS	STREET TYPES
	M.A. & M.C.
Scale: NONE	Date: APRIL 1, 1965
Drawn By:	

APPROVED: *A. P. [Signature]*  
DIRECTOR OF PUBLIC WORKS

A-3

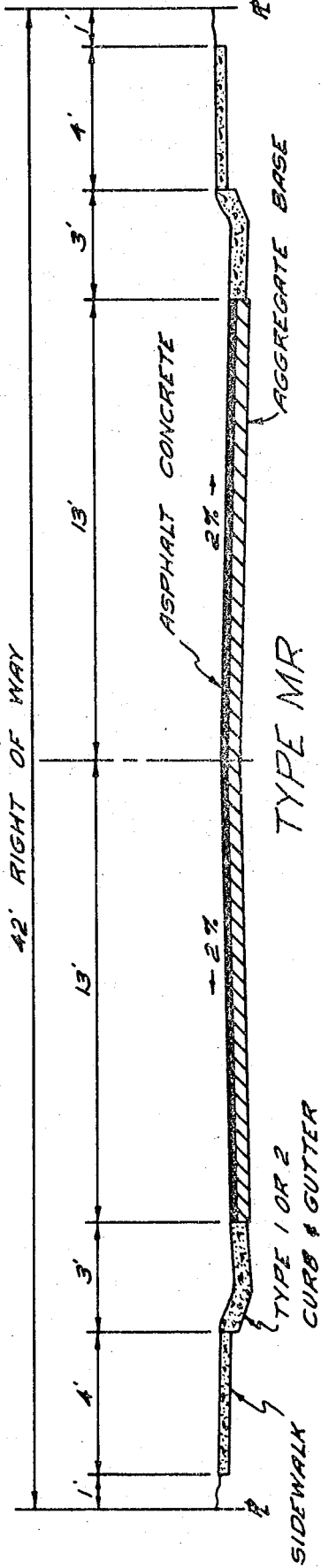

MINOR RESIDENTIAL

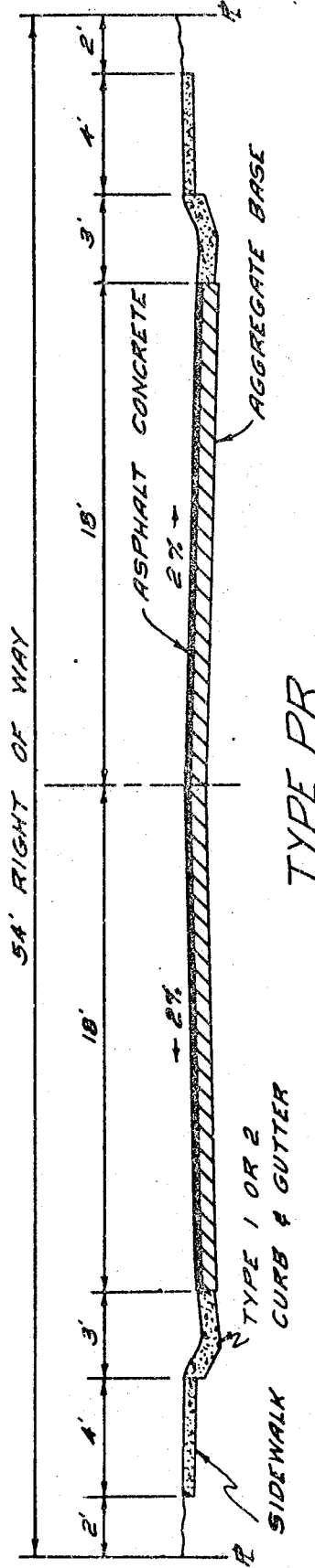

PRIMARY RESIDENTIAL

SACRAMENTO COUNTY DEPARTMENT OF PUBLIC WORKS HIGHWAY & BRIDGE DIVISION	
TYPICAL SECTIONS TYPE MR & PR STREETS	
Scale: NONE Date: 1-1-60 Drawn By: J/S	A-4

APPROVED: *A. L. Kieffer*  
DIRECTOR OF PUBLIC WORKS

REDUCED

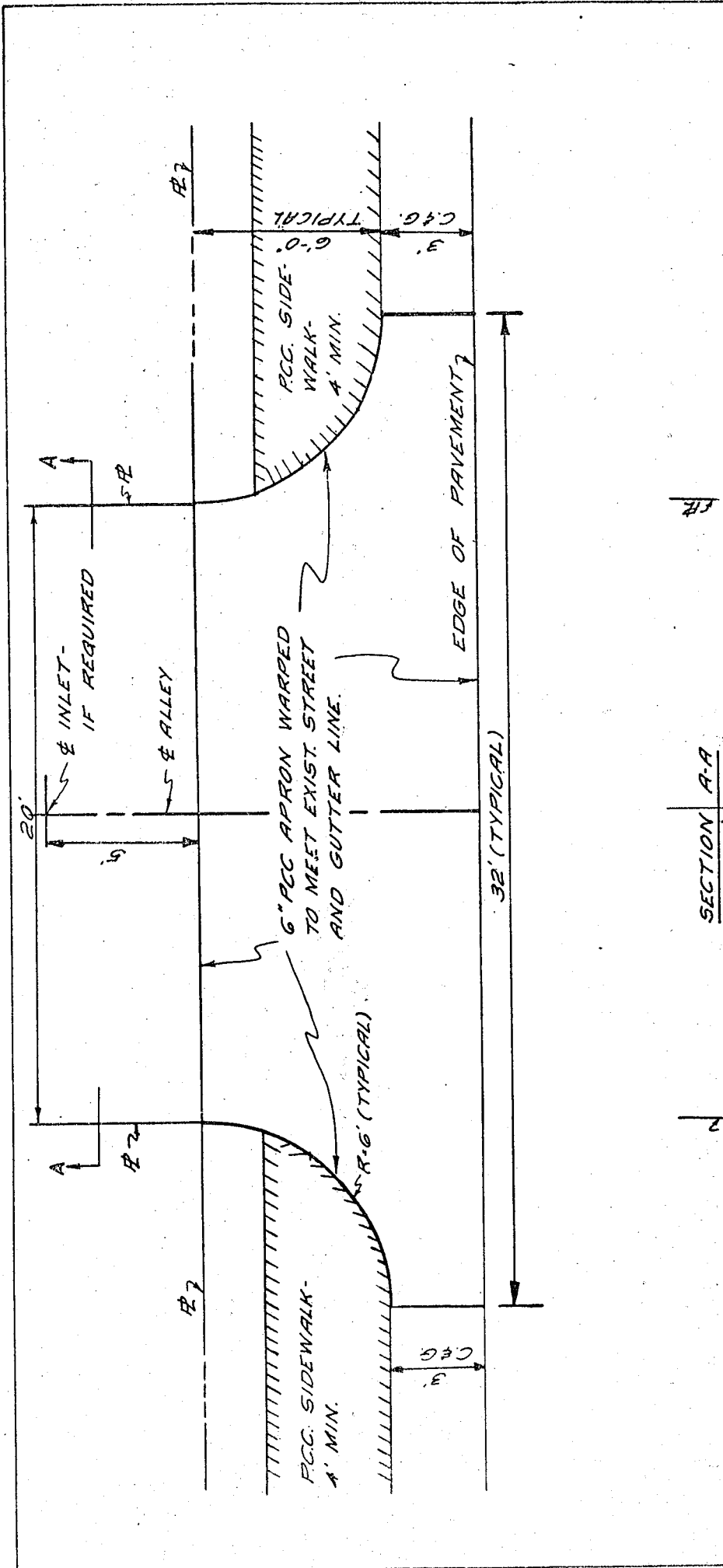

SACRAMENTO COUNTY  
 DEPARTMENT OF PUBLIC WORKS  
 HIGHWAY & BRIDGE DIVISION  
 ALLEY DETAILS  
 Scale: NONE  
 Date: 10-3-66  
 Drawn By:

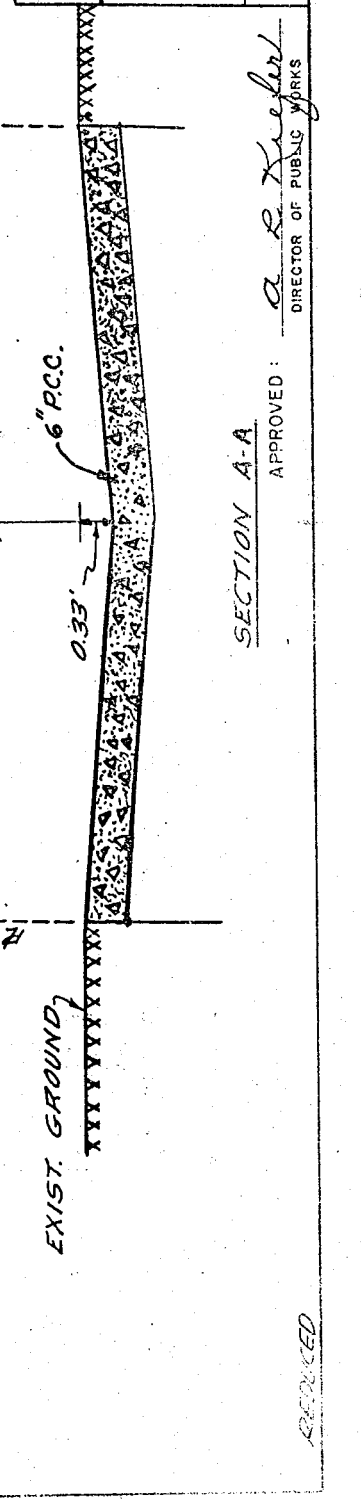

APPROVED: *A. R. Kuefer*  
 DIRECTOR OF PUBLIC WORKS

SECTION A-A

A-5

REVISED

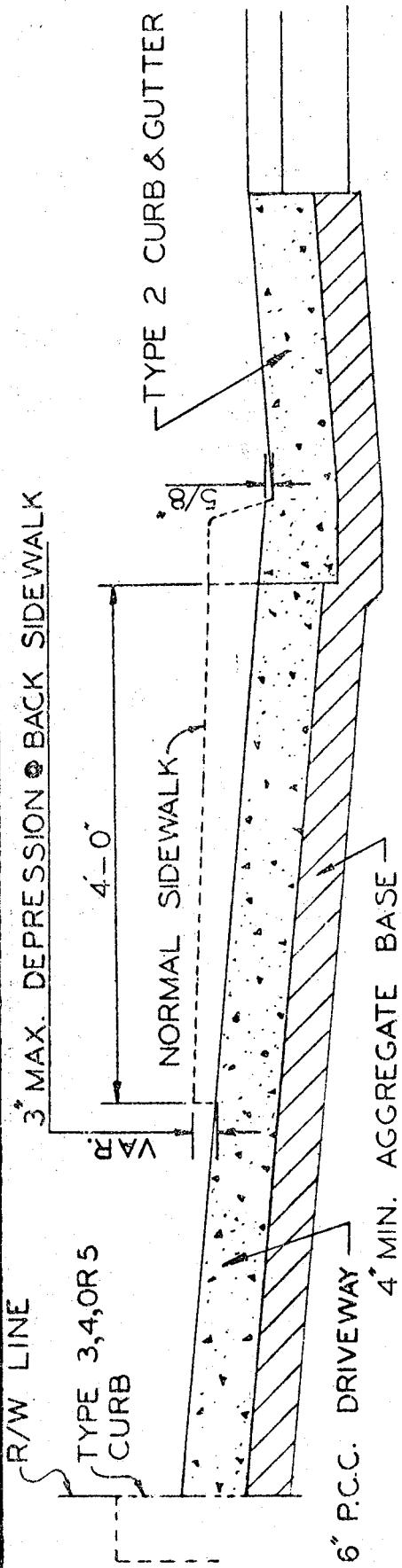

TYPICAL DRIVEWAY SECTION

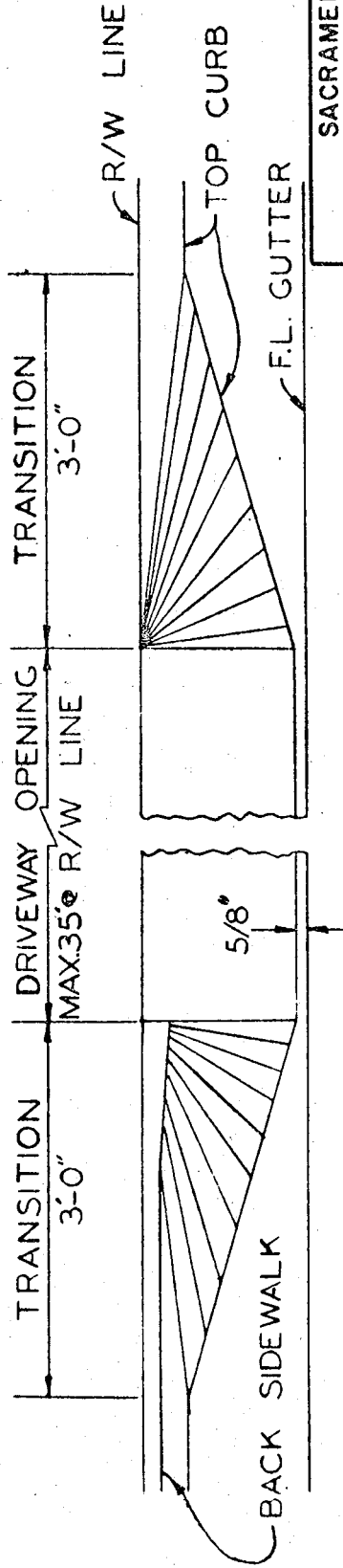

SACRAMENTO COUNTY  
 DEPARTMENT OF PUBLIC WORKS  
 HIGHWAY & BRIDGE DIVISION

COMMERCIAL DRIVEWAYS

Scale: NONE  
 Date: APRIL 1, 1965  
 Drawn By:

APPROVED: *A. R. Kiefer*  
 DIRECTOR OF PUBLIC WORKS

A-6

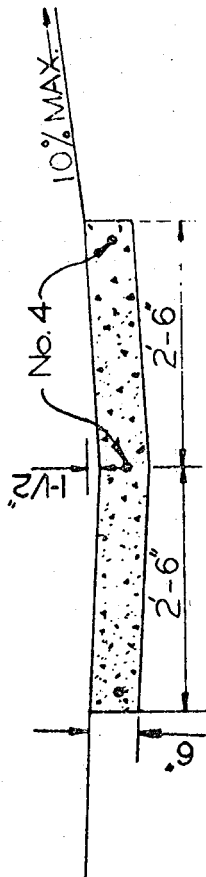
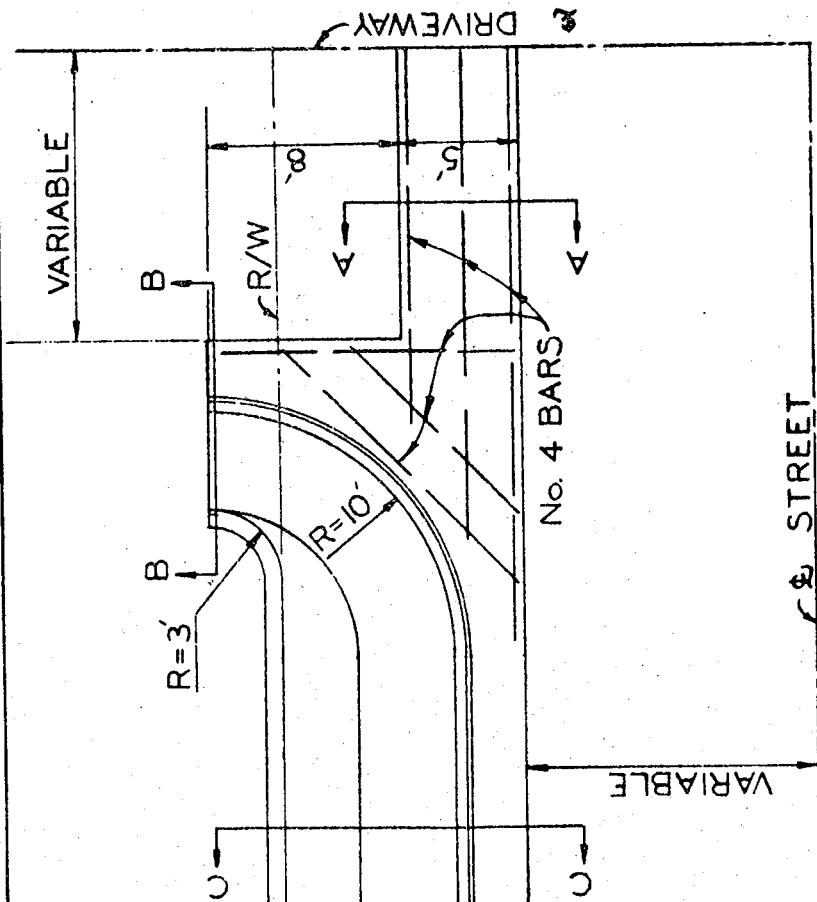

SECTION A-A

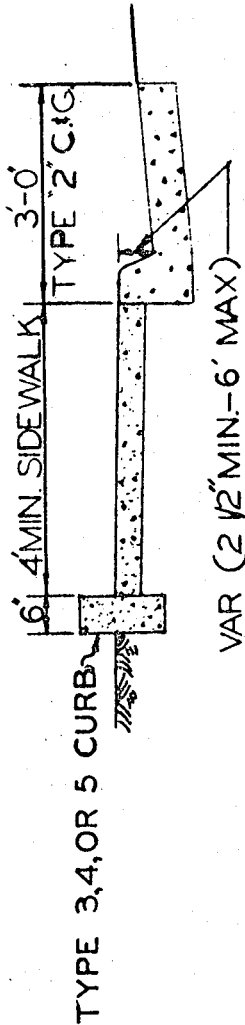

SECTION B-B

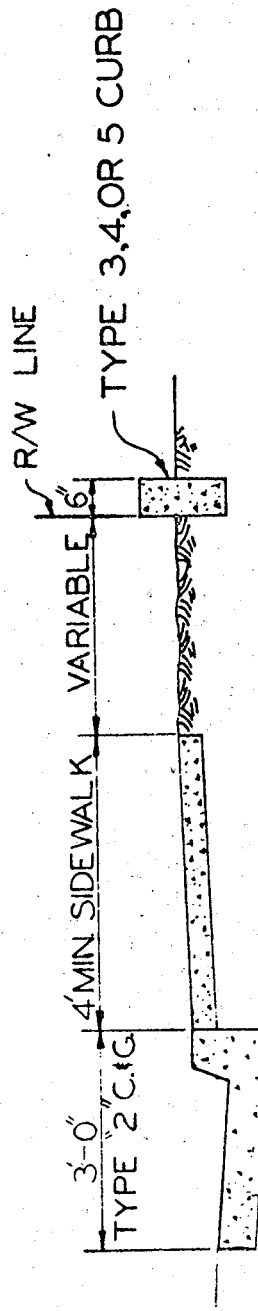

SECTION C-C

SACRAMENTO COUNTY  
DEPARTMENT OF PUBLIC WORKS  
HIGHWAY & BRIDGE DIVISION

SPECIAL COMMERCIAL

FRONTAGE ENTRANCE

Scale: NONE  
Date: APRIL 1, 1965  
Drawn By:

APPROVED: *A. P. Pfeiffer*  
DIRECTOR OF PUBLIC WORKS

A-7

# GENERAL NOTES

FRONTAGE TO BE MEASURED ALONG HIGHWAY R/W LINE AND FROM THE INTERSECTION OF PROJECTED R/W TANGENTS ON CORNER LOTS.

DRIVEWAYS NOT PERMITTED WITHIN 10 FT. OF ADJACENT PROPERTY LINES AND/OR WITHIN 25 FT. OF INTERSECTING R/W TANGENTS WHOSE INTERIOR ANGLES OF INTERSECTION ARE GREATER THAN 70°. ALL OTHER CASES TO BE SUBMITTED TO THE DIRECTOR OF PUBLIC WORKS FOR SPECIFIC APPROVAL.

20 FT. MINIMUM ALLOWABLE DISTANCE BETWEEN DRIVEWAYS FOR LESS THAN 200 FT. FRONTAGE AND 40 FT. MINIMUM ALLOWABLE DISTANCE FOR FRONTAGE OF 200 FT. & OVER.

20 FT. MINIMUM & 35 FT. MAXIMUM DRIVEWAY WIDTH MEASURED AT R/W LINE.

TOTAL FRONTAGE IN FT.	TOTAL ALLOWABLE WIDTH OF ALL DRIVEWAYS IN FT.
0	20
41	30
51	40
81	50
91	60
111	70
201	75
301	105
401	140
OVER	175

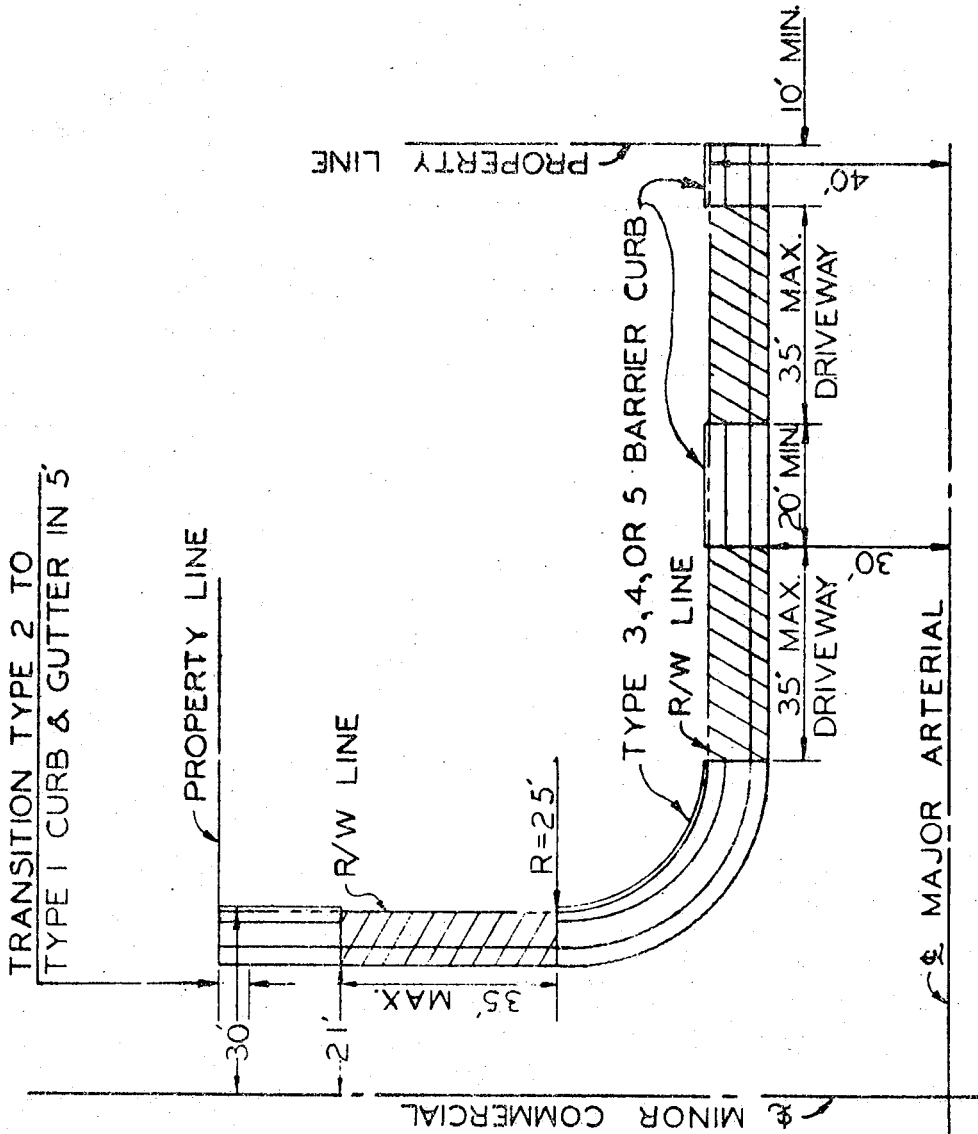

SACRAMENTO COUNTY  
DEPARTMENT OF PUBLIC WORKS  
HIGHWAY & BRIDGE DIVISION

COMMERCIAL FRONTAGE AND  
DRIVEWAY REGULATIONS

Scale: NONE  
Date: APRIL 1 1965  
Drawn By:

APPROVED:

*A. R. ...*  
DIRECTOR OF PUBLIC WORKS

A-8

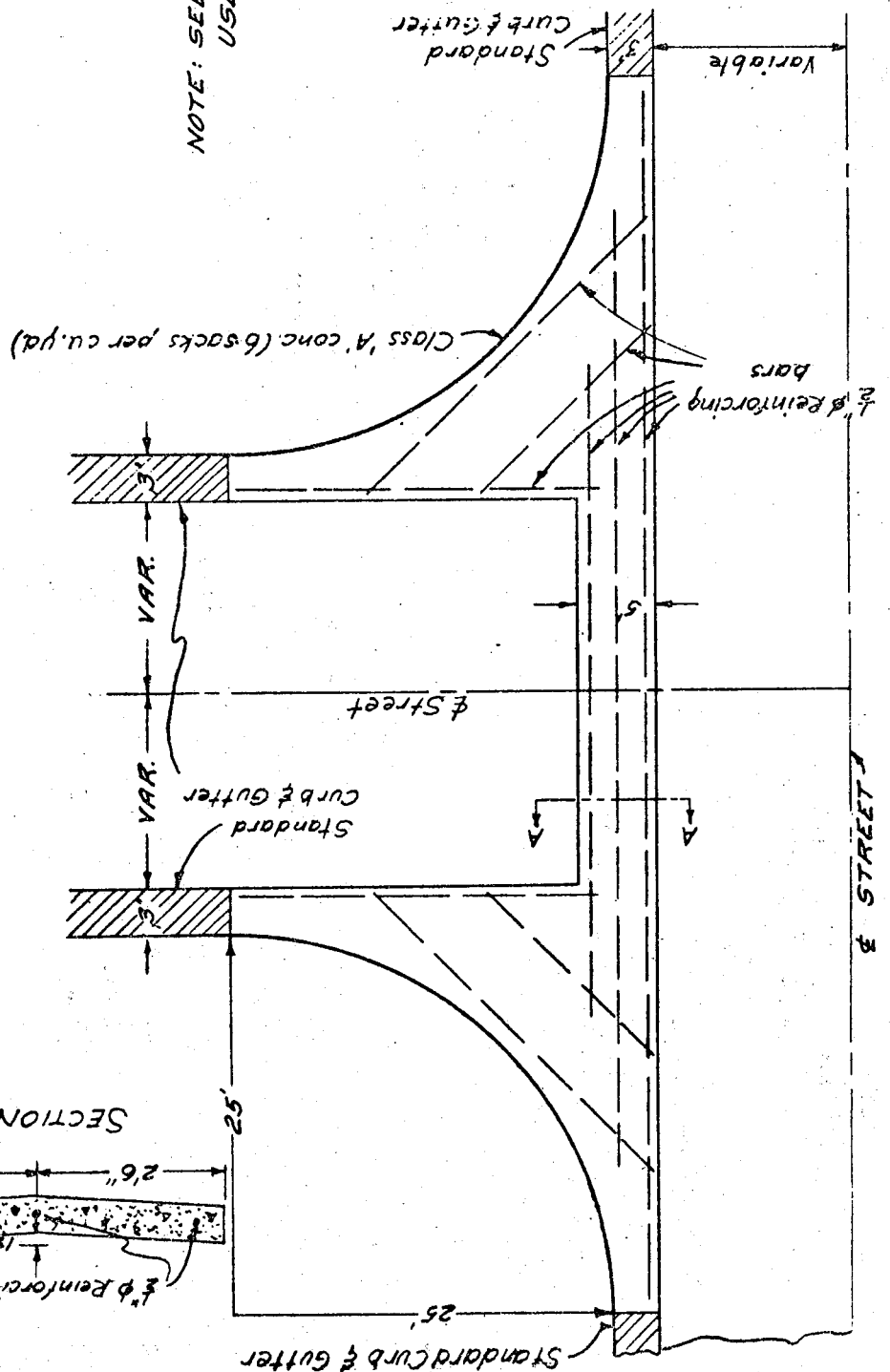
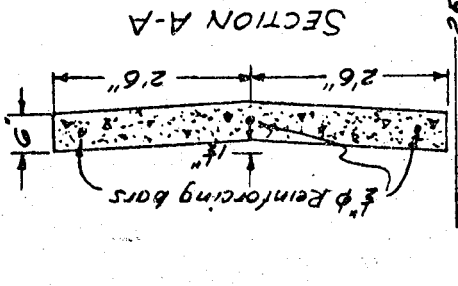

NOTE: SEE SPECIFICATIONS FOR USE LIMITATIONS.

SACRAMENTO COUNTY DEPARTMENT OF PUBLIC WORKS HIGHWAY & BRIDGE DIVISION	
CROSS GUTTER DESIGN	
Scale: NONE Date: 1-1-60 Drawn By:	A-9

APPROVED: *R. E. Nelson*  
DIRECTOR OF PUBLIC WORKS

STREET

REDUCED



REDUCED

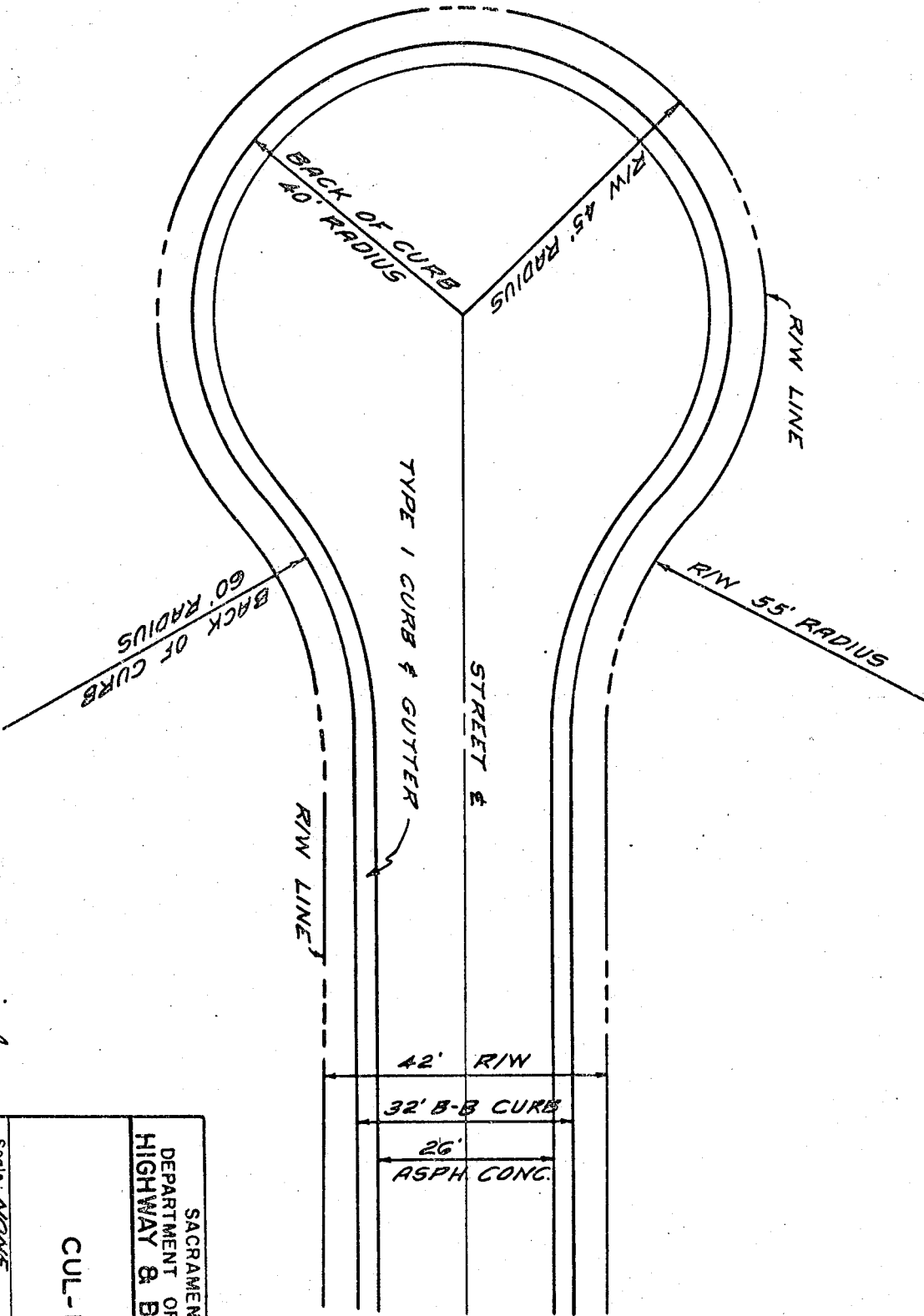

APPROVED: *A. P. Keenan*  
 DIRECTOR OF PUBLIC WORKS

SACRAMENTO COUNTY  
 DEPARTMENT OF PUBLIC WORKS  
 HIGHWAY & BRIDGE DIVISION

CUL-DE-SAC

Scale: NONE  
 Date: 1-1-60  
 Drawn By: UJS

A-10

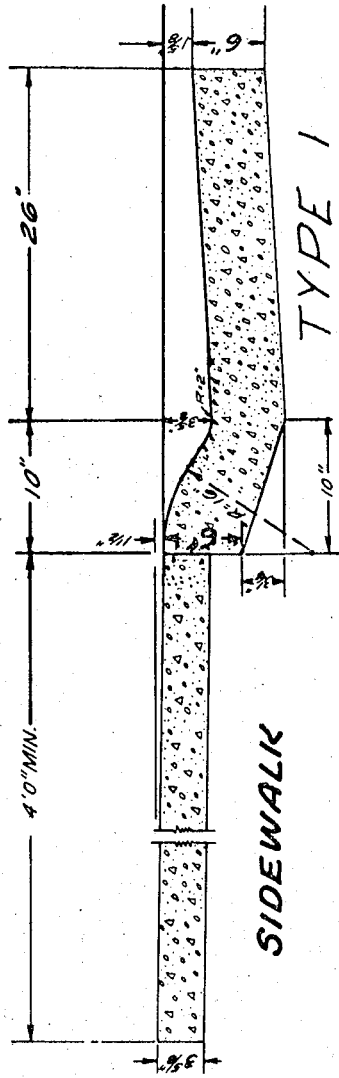

**TYPE 1**  
ROLLED CURB & GUTTER

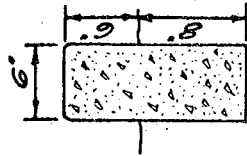

**TYPE 3**  
BARRIER CURB  
FOR COMMERCIAL  
FRONTAGE

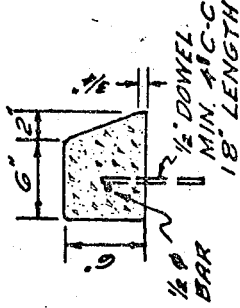

**TYPE 4**  
BARRIER CURB

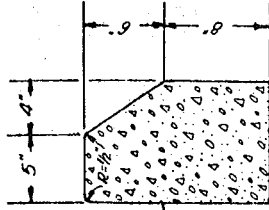

**TYPE 5**  
BARRIER CURB

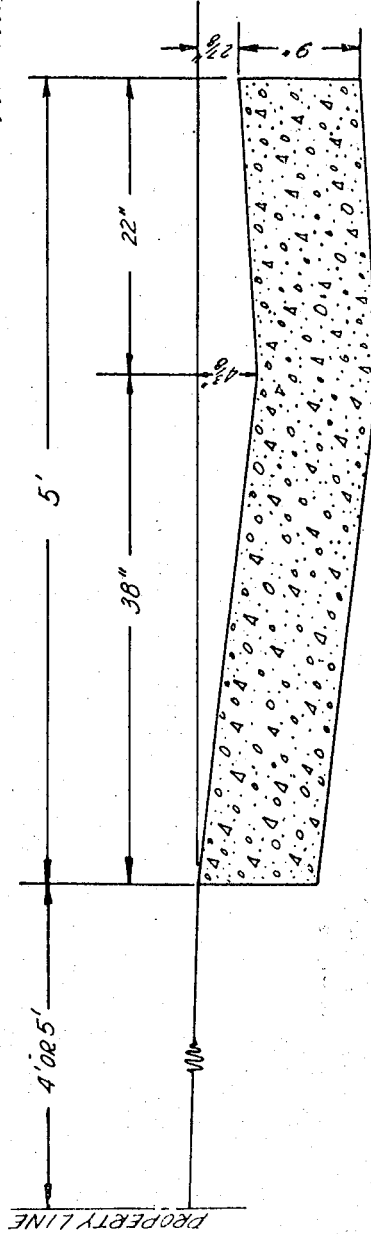

**TYPE 6**  
MODIFIED 'V' GUTTER

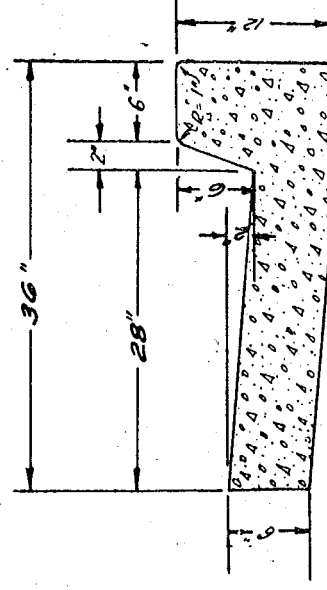

**TYPE 2**  
VERTICAL CURB & GUTTER

NOTE:  
LOCATE 1/2" TRANSVERSE EXPANSION JOINTS OF ASPHALT IMPREGNATED  
CELOTEX IN SIDEWALK, CURB AND GUTTER AT 20' INTERVALS.  
ALL CONCRETE TO BE CLASS "B"

SACRAMENTO COUNTY DEPARTMENT OF PUBLIC WORKS HIGHWAY & BRIDGE DIVISION	
CURBS & GUTTERS	
RESIDENTIAL & COMMERCIAL DEVELOPMENT	
Scale: NONE Date: 1-1-60 Drawn By:	A-11

APPROVED: *A. E. Kieffer*  
DIRECTOR OF PUBLIC WORKS

REVISED 7-25-61 A.J.B.

MATERIAL SHALL CONFORM TO SECTION 84 OF STATE SPECIFICATIONS. ALL DIMENSIONS  $\pm 1/4"$  TOLERANCE. LENGTH TO BE VARIED TO MEET PARTICULAR CONDITION. ALL PLACEMENTS TO BE APPROVED BY DIRECTOR OF PUBLIC WORKS.

SACRAMENTO COUNTY  
DEPARTMENT OF PUBLIC WORKS  
HIGHWAY & BRIDGE DIVISION

RAISED TRAFFIC BARS

Scale: NONE  
Date:  
Drawn By:

APPROVED: *A. S. Kuebler*  
DIRECTOR OF PUBLIC WORKS

A-12

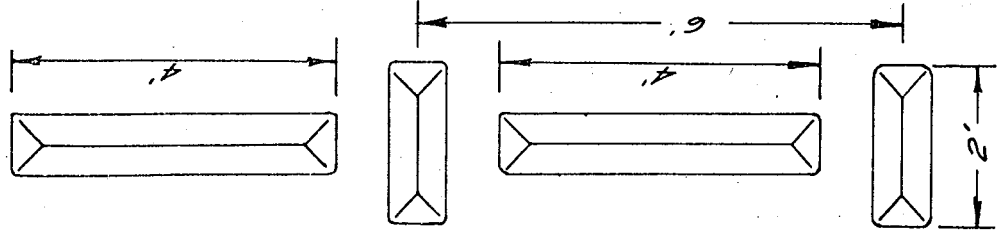

TRAFFIC FINS

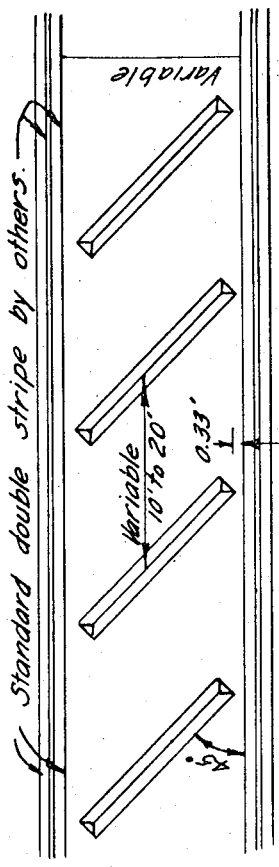
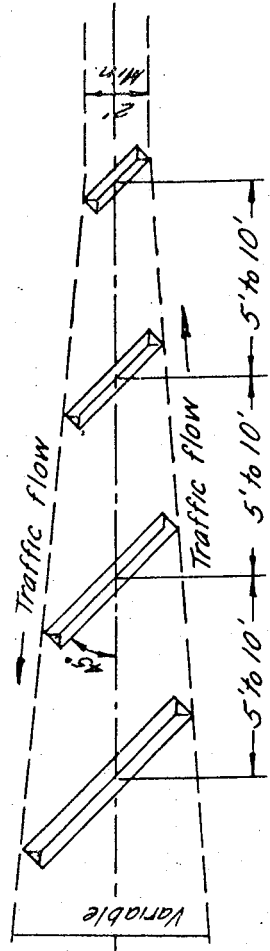
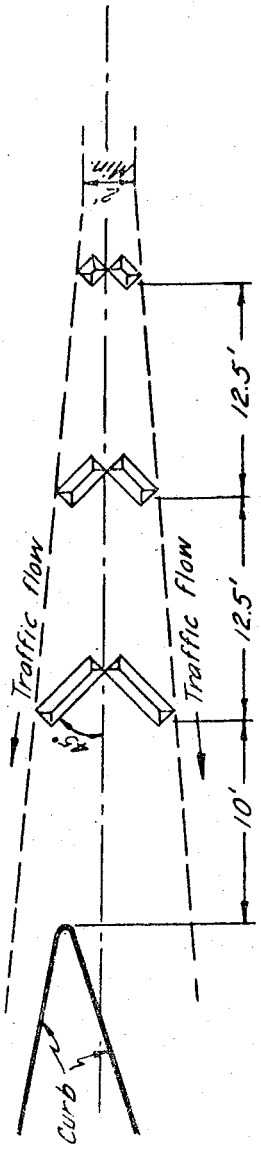

SIDE VIEW

CROSS SECTION

REDIMED

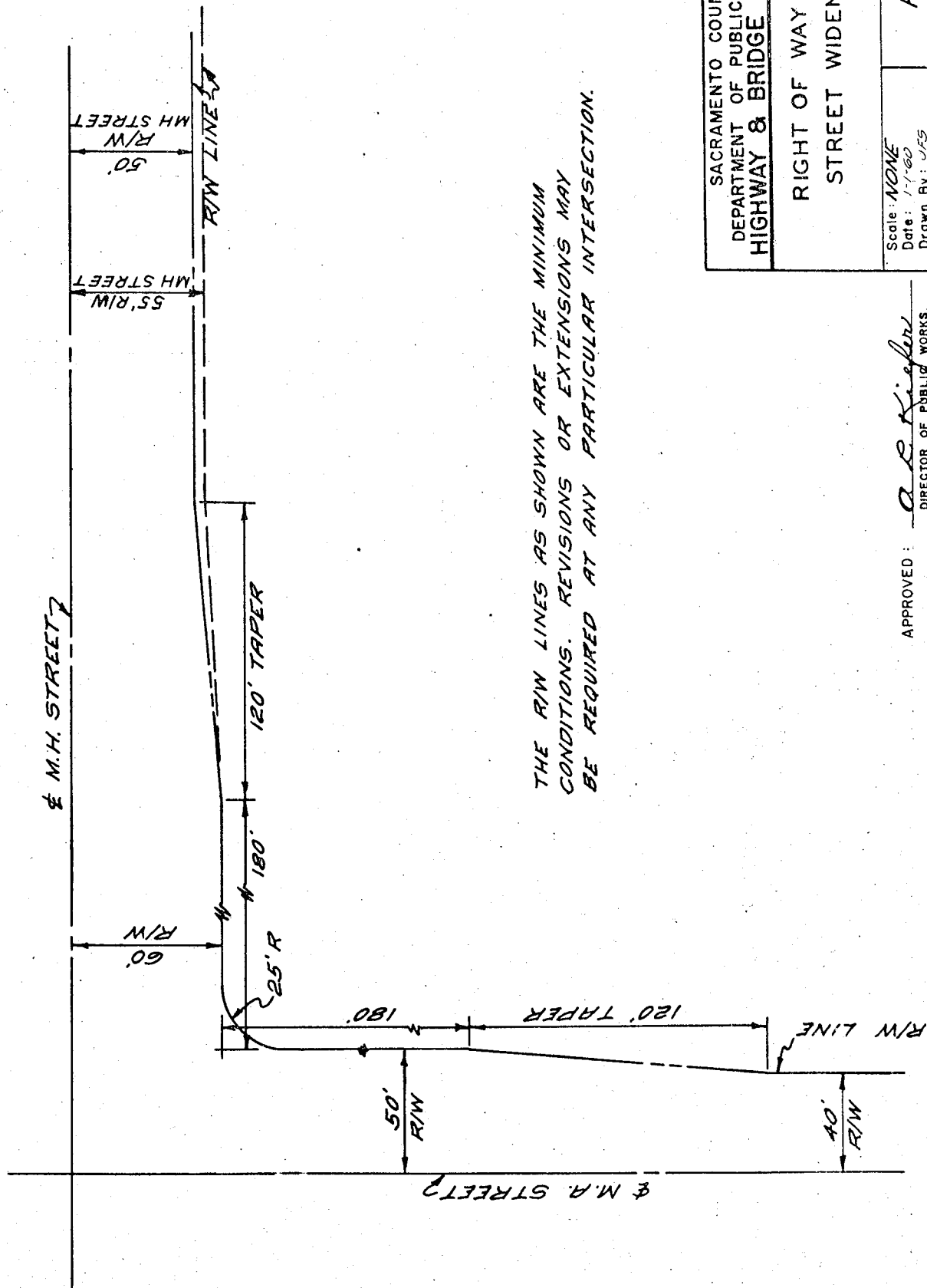

THE R/W LINES AS SHOWN ARE THE MINIMUM CONDITIONS. REVISIONS OR EXTENSIONS MAY BE REQUIRED AT ANY PARTICULAR INTERSECTION.

SACRAMENTO COUNTY DEPARTMENT OF PUBLIC WORKS HIGHWAY & BRIDGE DIVISION	
RIGHT OF WAY FOR STREET WIDENING	
Scale: NONE Date: 1-1-60 Drawn By: JFS	A-13

APPROVED: *A. E. Kieffer*  
DIRECTOR OF PUBLIC WORKS

REDUCED

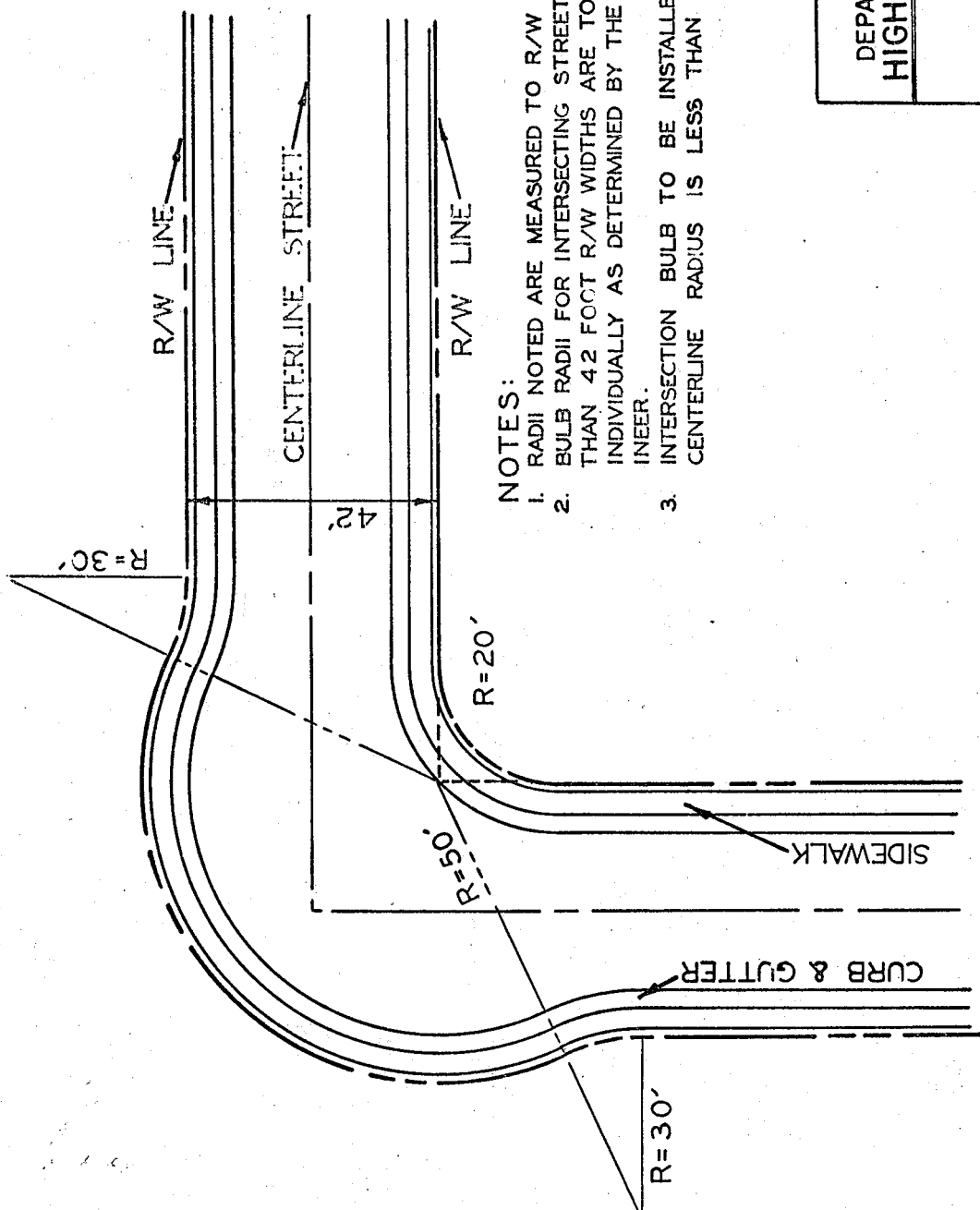

**NOTES:**

1. RADII NOTED ARE MEASURED TO R/W LINES.
2. BULB RADII FOR INTERSECTING STREETS GREATER THAN 42 FOOT R/W WIDTHS ARE TO BE ESTABLISHED INDIVIDUALLY AS DETERMINED BY THE COUNTY ENGINEER.
3. INTERSECTION BULB TO BE INSTALLED WHERE THE CENTERLINE RADIUS IS LESS THAN 125 FEET.

SACRAMENTO COUNTY DEPARTMENT OF PUBLIC WORKS HIGHWAY & BRIDGE DIVISION	
INTERSECTION BULB	
Scale: 1" = 30' Date: 8-1-65 Drawn By:	A-14

APPROVED: *A. C. Hughes*  
 DIRECTOR OF PUBLIC WORKS

REVISED

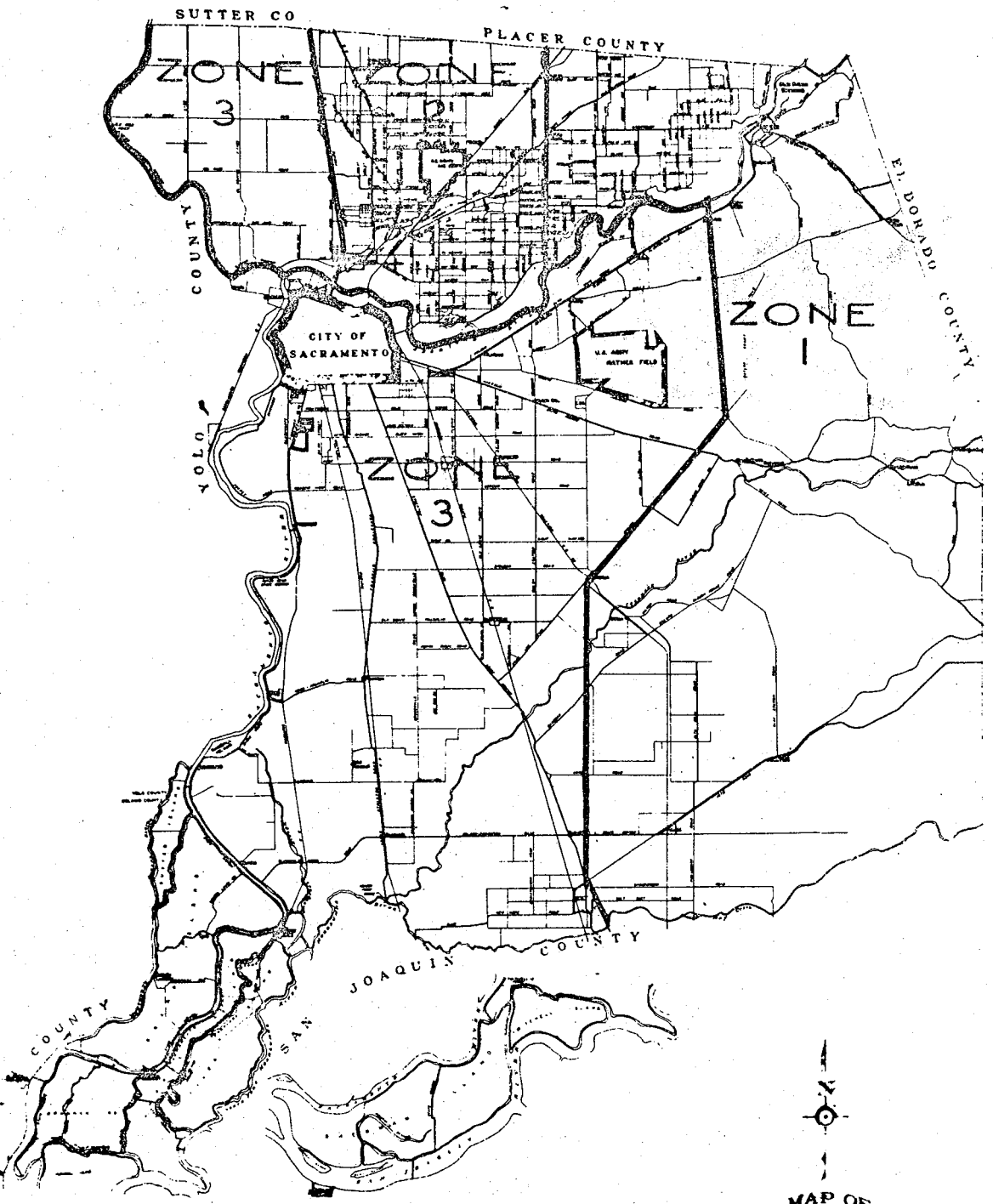

APPROVED: *R. E. K. [Signature]*  
 DIRECTOR OF PUBLIC WORKS

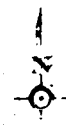

MAP OF  
 THE COUNTY OF  
**SACRAMENTO**  
 CALIFORNIA.

Scale: 1 inch = 4000 feet

SACRAMENTO COUNTY DEPARTMENT OF PUBLIC WORKS HIGHWAY & BRIDGE DIVISION	
DRAINAGE ZONES	
Scale: NONE	C-1
Date: 1-1-60 Drawn By:	

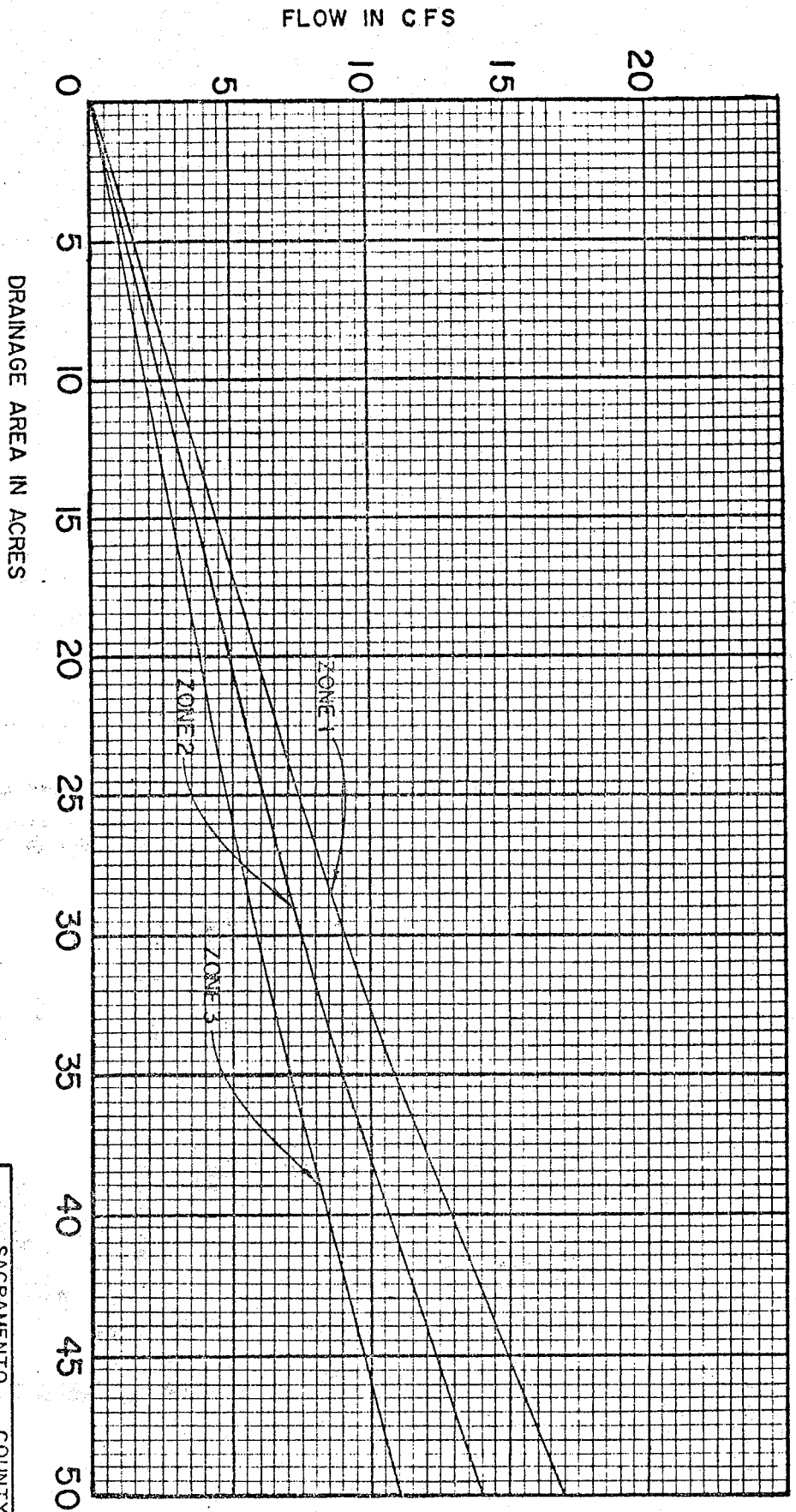

APPROVED: *A. E. Kuebler*  
 DIRECTOR OF PUBLIC WORKS

Scale: \_\_\_\_\_  
 Date: 2-26-63  
 Drawn BY: \_\_\_\_\_

C-2

SACRAMENTO COUNTY  
 DEPARTMENT OF PUBLIC WORKS  
 HIGHWAY & BRIDGE DIVISION

DESIGN RUNOFF

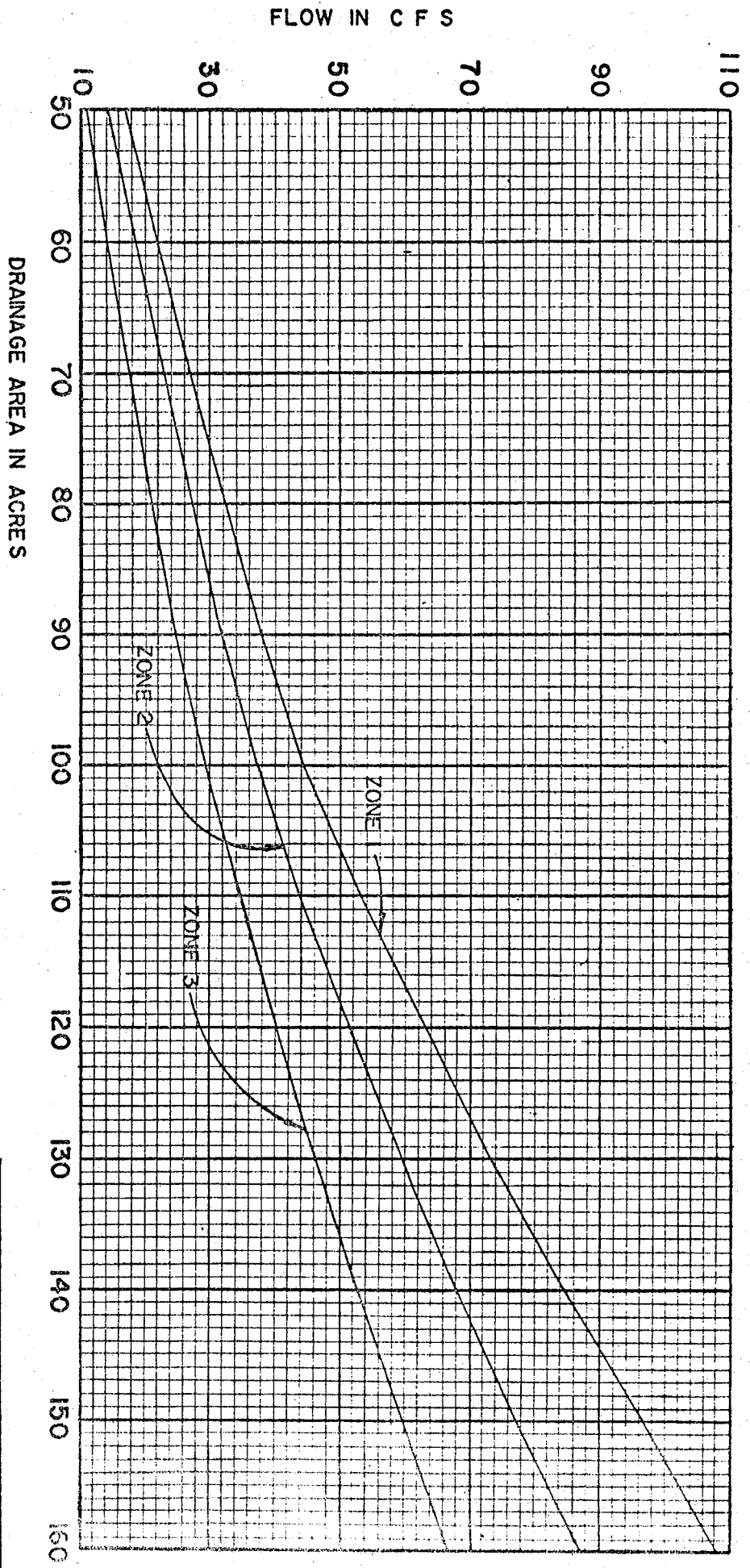

SACRAMENTO COUNTY  
 DEPARTMENT OF PUBLIC WORKS  
 HIGHWAY & BRIDGE DIVISION

DESIGN RUNOFF

APPROVED: *[Signature]*  
 DIRECTOR OF PUBLIC WORKS

Scale: \_\_\_\_\_  
 Date: 2-26-63  
 Drawn By: C-3



STR. NUMBER	LOCATION	UPPER STR.	LOWER STR.	PIPE SIZE IN INCHES	LENGTH IN FEET	UPPER STR. ELEV.	LOWER STR. ELEV.	UPPER $\pi$	LOWER $\pi$	PIPE SLOPE	UPPER HYD. ELEV. (WHEN REQUIRED)	LOWER HYD. ELEV. (WHEN REQUIRED)	HYD. SLOPE (WHEN REQUIRED)	CONTRIBUTING AREA IN ACRES	RUNOFF FACTOR CFS PER ACRE	TOTAL CFS	PIPE CAPACITY	PERCENT FULL	REMARKS	
1	25 FT RT OF STA. 99+61			4 FAIR ORKS	BLVD. (E)									41.4	0.322	13.3			MANHOLE	
	RCCP	1	2	36	327	36.25	36.19	29.88	29.25	0.028	34.10	33.77	0.010			13.3	19	70		
2	25 FT RT STA.	96+34	4	FAIR ORKS	BLVD. (E)	RT INT. MANHOLE ST.								49.2	0.336	16.6			MANHOLE	
	RCCP	2	3	36	285	36.19	36.35	29.25	28.66	0.020	33.77	33.45	0.010			16.6	19	88		
3	25 FT. LT STA.	12+60	4	MANHOLE	ST.															INT.-X-CULV.

1. TOP OF STRUCTURE ELEVATION WILL BE TAKEN AT GUTTER FLOWLINE ON INLETS AND AT BOTTOM OF FRAME ON MANHOLES.
2. HYDRAULIC ELEVATIONS SHALL BE A MINIMUM OF 0.5' BELOW GRATE ELEV.
3. PIPE COMPUTATIONS SHALL BE ACCOMPANIED BY A DRAINAGE MAP OR WORK SHEET SHOWING THE OUTLINE AND AREA OF THE DRAINAGE BASIN CONTRIBUTING TO EACH INLET.
4. LENGTH OF PIPE SHALL BE TO & OF STRUCTURES FOR HYDRAULIC COMPUTATIONS.
5. STRUCTURE LOCATIONS SHALL BE TAKEN AT & OF STRUCTURE.

REDUCED

APPROVED: *A. R. Kiefer*  
DIRECTOR OF PUBLIC WORKS

Scale: \_\_\_\_\_  
Date: \_\_\_\_\_  
Drawn By: G.S.

C-4

SACRAMENTO COUNTY  
DEPARTMENT OF PUBLIC WORKS  
HIGHWAY & BRIDGE DIVISION  
STANDARD DRAINAGE  
COMPUTATIONS

CLASS	CONCRETE PIPE					CORRUGATED METAL PIPE, UNSTREETED						V.C.P. EXTRA STRENGTH
	C-14		I	II	III	IV	V	16 GA.	14 GA.	12 GA.	10 GA.	
DIA.	55	ES										
10	13	30					60	80				30
12	12	26					50	70				26
15	12	26					40	60	100			26
18	12	29					35	50	80	100		29
21	12	29					17	47	72	82		24
24	12	24					19 *	40	60	77		19
27							17 *	32	47	72		19
30							16 *	25	40	60		20
33							13 *	18	33	48		
36								18 *	28	38		
42								16 *	24	29		
48								14 *	20	25		
54								12 *	17 *	20		
60			14	16	21	31	57		20	30		
66			15	17	22	32	56		14 *	20		
72			15	18	23	33	56		7 *	16		

MAXIMUM ALLOWABLE COVER-DRAINAGE PIPES  
 (MEASURED SURFACE TO BOTTOM OF TRENCH IN FEET)

NOTES  
 1. CONCRETE PIPE SHALL CONFORM TO ASTM C-76  
 2. VITRIFIED CLAY PIPE SHALL BE EXTRA STRENGTH AND CONFORM TO ASTM C-278, CL. II  
 3. ALL DEPTHS SHOWN FOR FLEXIBLE PAVEMENT ONLY.  
 4. MIN. COVER ON V.C.P. EXTRA STRENGTH SHALL CONFORM TO THAT OF CONCRETE PIPE CLASS III.  
 5. 12" MIN. COVER ON CONCRETE PIPE OUTSIDE STREET AREAS.

CLASS	CONCRETE PIPE					CORRUGATED METAL	
	C-14		I	II	III	IV	V
DIA.	55	ES					
ALL SIZE	27"	24"	27"	24"	18"	12"	12"

MINIMUM ALLOWABLE COVER-DRAINAGE PIPES  
 (MEASURED SURFACE TO TOP OF PIPE IN INCHES)

PIPE - ALL SIZES H-20 LOADING  
 MAJOR STREETS 1/2 OR 9" MIN.  
 MINOR STREETS 3/4 OR 6" MIN.

SACRAMENTO COUNTY  
 DEPARTMENT OF PUBLIC WORKS  
 HIGHWAY & BRIDGE DIVISION

COVER REQUIREMENTS

APPROVED: *R. R. Kiebert*  
 DIRECTOR OF PUBLIC WORKS

Scale: 1"-1'-0"  
 Date: 1-1-60  
 Drawn By:

C-5

ALLOWABLE COVER - ASBESTOS CEMENT DRAINAGE PIPES

PIPE DIAMETER (IN.)	MAXIMUM FILL HEIGHT (FEET)					MINIMUM COVER (INCHES)				
	CLASS					CLASS				
	1500	2400	3300	4000	5000	1500	2400	3300	4000	5000
8	6	17	40	40	40	24	16	12	12	12
10	4	12	40	40	40	29	19	12	12	12
12	4	10	17	40	40	32	21	15	12	12
14	4	9	15	22	40	34	24	17	12	12
15	4	9	14	20	40	35	26	18	12	12
16	4	8	13	19	40	36	27	19	12	12
18	-	8	12	17	24	-	29	21	14	12
20	-	7	11	15	21	-	30	23	16	12
21	-	7	11	14	20	-	31	24	17	14
22	-	6	10	13	18	-	32	26	19	15
24	-	6	10	12	17	-	33	27	20	16
27	-	-	9	11	15	-	-	29	24	20
30	-	-	8	10	13	-	-	33	27	23
33	-	-	-	10	12	-	-	-	28	27
36	-	-	-	8	11	-	-	-	29	30

ASBESTOS CEMENT DRAINAGE PIPE MAY BE USED UNDER STREETS 60" OR WIDER BY SPECIAL AUTHORIZATION ONLY.

SACRAMENTO COUNTY  
 DEPARTMENT OF PUBLIC WORKS  
 HIGHWAY & BRIDGE DIVISION  
 ASBESTOS CEMENT PIPE

Scale: NONE  
 Date: 8/1/65  
 Drawn By: C-5A

APPROVED: *A. E. [Signature]*  
 DIRECTOR OF PUBLIC WORKS

ALLOWABLE COVER - ALUMINUM DRAINAGE PIPES

PIPE DIA. (INCHES)	TYPE OF SHAPE	MIN. COVER (INCHES)	MAXIMUM FILL HEIGHT (FEET) FOR GAUGES AND THICKNESSES					
			16 0.060"	14 0.075"	12 0.105"	10 0.135"	8 0.164"	
8	FULL CIRCLE	9	50					
10	"	"	40					
12	"	"	35	40	50			
15	"	"	32	35	40			
18	"	"	26	30	35			
21	"	"	21	25	30			
24	"	"	13	21	30			
30	"	"	10*	19	25	30		
	5% VERTICALLY ELONGATED	"		24	30	35		
36	FULL CIRCLE	10	10"	10	18	25	30	
	5% VERTICALLY ELONGATED	"			21	30	35	
42	"	12		10	20	25	30	
48	"	15		10	18	25	30	
54	"	"		10*	18	22	30	
60	"	18		10*	17	25		
66	"	21		10*	15	20		
72	5% FIELD STRUTTED	24				20	25	
78	"	"				16	20	
84	"	"					15	
93	"	"					10	

\* USE ONLY UNDER UNTRAVELED AREAS  
 ALUMINUM DRAINAGE PIPE MAY BE USED  
 UNDER STREETS 60' OR WIDER BY SPECIAL  
 AUTHORIZATION ONLY.

APPROVED :

*A. P. Steinfeld*  
 DIRECTOR OF PUBLIC WORKS

SACRAMENTO COUNTY  
 DEPARTMENT OF PUBLIC WORKS  
 HIGHWAY 8 BRIDGE DIVISION

CORRUGATED  
 ALUMINUM PIPE

Scale : NONE  
 Date : 8/1/65  
 Drawn By :

C - 5 B

# DRAINAGE PIPE EQUIVALENT PIPE SIZES

DRAINAGE PIPE	V.C.P. OR A.C. N = 0.013	R.C.P. OR C.P. N = 0.015	C.I.P. N = 0.0165	C.M.P. $\frac{1}{2}$ " X 2 $\frac{3}{8}$ " N = 0.021	C.M.P. 1" X 3" N = 0.024
10"	10"	10"	-	12"	12"
12"	12"	12"	-	15"	15"
15"	15"	15"	-	18"	18"
18"	18"	18"	-	21"	21"
21"	20"	21"	24"	24"	27"
24"	22"	24"	24"	27"	30"
27"	27"	27"	30"	30"	33"
30"	30"	30"	30"	33"	36"
33"	30"	33"	36"	36"	42"
36"	33"	36"	36"	42"	42"
42"	-	42"	42"	48"	48"
48"	-	48"	48"	54"	60"
54"	-	54"	54"	60"	66"
60"	-	60"	60"	66"	72"
66"	-	66"	66"	72"	84"
72"	-	72"	72"	84"	84"
78"	-	78"	84"	90"	96"
84"	-	84"	84"	96"	-

**NOTES:**

1. PIPE STRENGTH REQUIREMENTS FOR EACH REACH SHALL BE SHOWN ON THE PLANS AS DETERMINED FROM CHARTS C-5, C-5A AND C-5B.
2. ALTERNATES AND CLASSES OF PIPE USED SHALL BE INDICATED ON THE "AS BUILT" PLANS.
3. FOR CASES WHERE THIS CHART IS NOT APPLICABLE THE PLANS MUST INDICATE THE SIZE AND CLASS OF PIPE FOR EACH REACH.
4. USE N=0.015 FOR DESIGN OF DRAINAGE PIPE 21" DIA AND SMALLER. FOR PIPE LARGER THAN 21" DIA, USE N=0.0165.
- \*5. C.M.P WITH 1" X 3" CORRUGATIONS SHALL BE USED ONLY WITH WRITTEN APPROVAL FROM THE DIRECTOR OF PUBLIC WORKS.

APPROVED:   
 DIRECTOR OF PUBLIC WORKS

SACRAMENTO COUNTY  
 DEPARTMENT OF PUBLIC WORKS  
 HIGHWAY & BRIDGE DIVISION

EQUIVALENT DRAINAGE  
 PIPE TABLE

SCALE: NONE  
 DATE: 3-2-66  
 DRAWN BY: CEB

C-5C

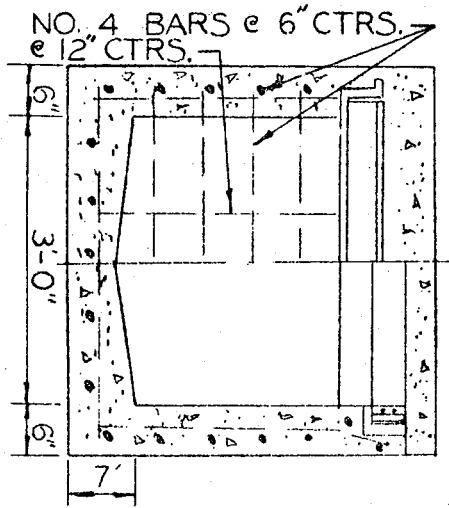
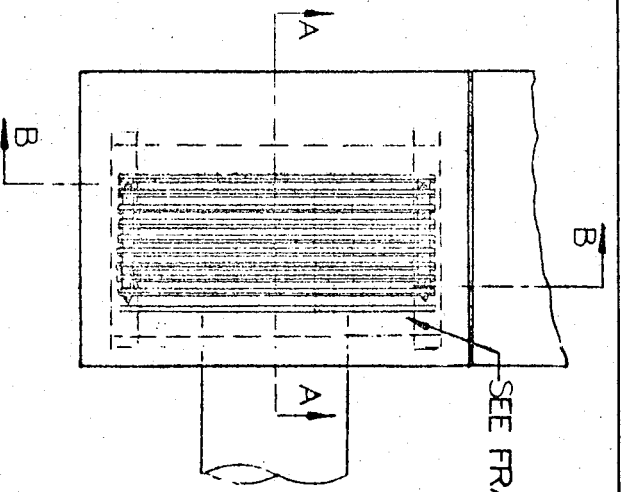

SECTION B-B

GRATE & FRAME

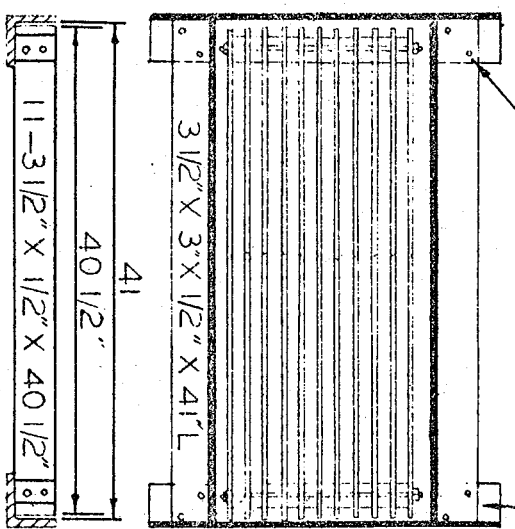

SPACER DET.

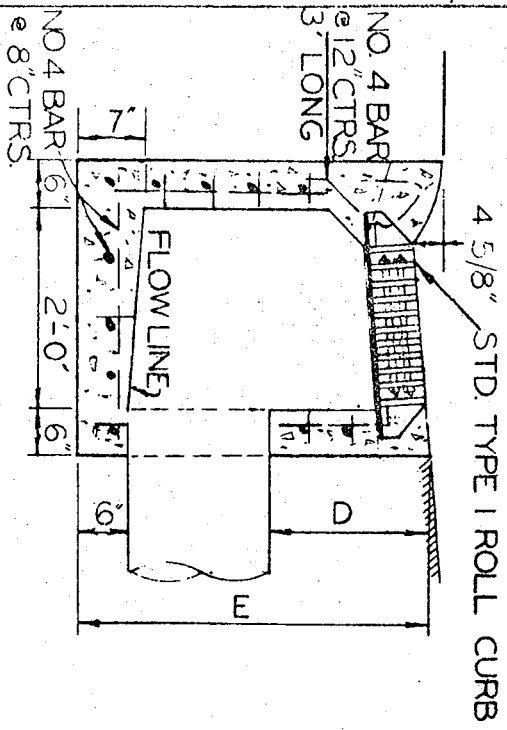
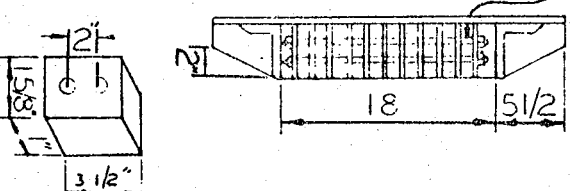

SECTION A-A

- NOTES:
1. DIMENSIONS D&E MAY VARY WITH EACH LOCATION
  2. ALL EXPOSED PARTS TO BE COATED WITH ASPHALT
  3. BAR SPACING SHALL BE 1" CLEAR SPACING.
  4. SUMP IS OPTIONAL.
  5. DEPRESSION IS STANDARD, SEE TYPE 2 STANDARD DRAWINGS.

SACRAMENTO COUNTY  
DEPARTMENT OF PUBLIC WORKS  
HIGHWAY & BRIDGE DIVISION

DROP INLET  
TYPE 1

APPROVED: *A. R. Kieffer*  
DIRECTOR OF PUBLIC WORKS

Scale: NONE  
Date: APRIL 1, 1965  
Drawn By:

C-6

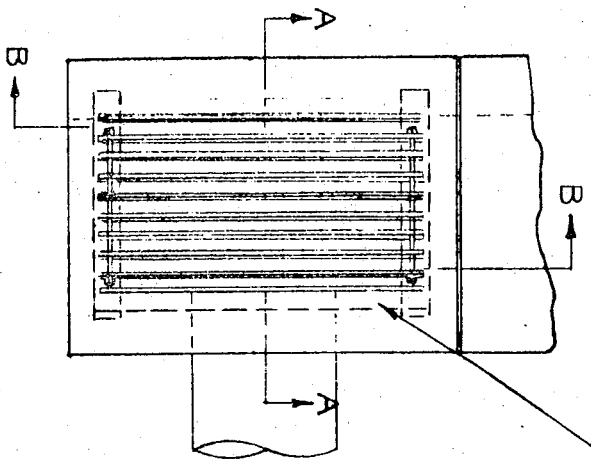

SEE FRAME & GRATE DET. TYPE 1 - STD. DWG.

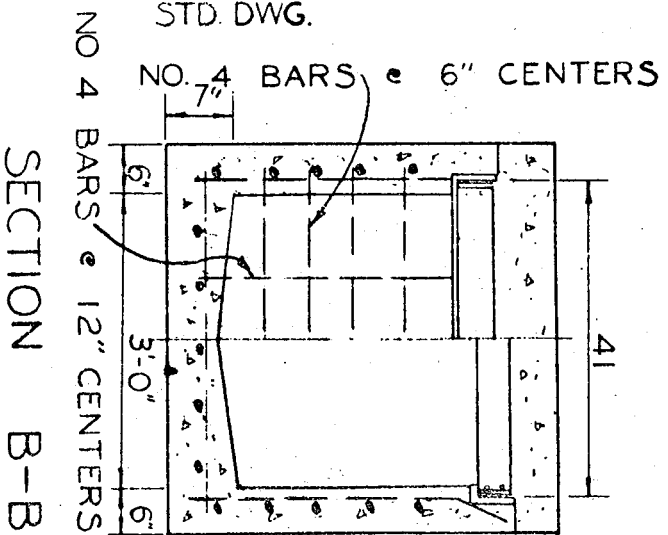

SECTION B-B

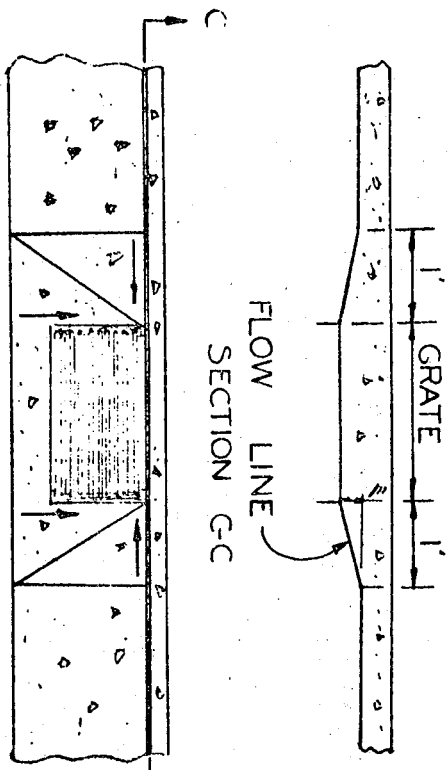

STANDARD DEPRESSION

PLAN

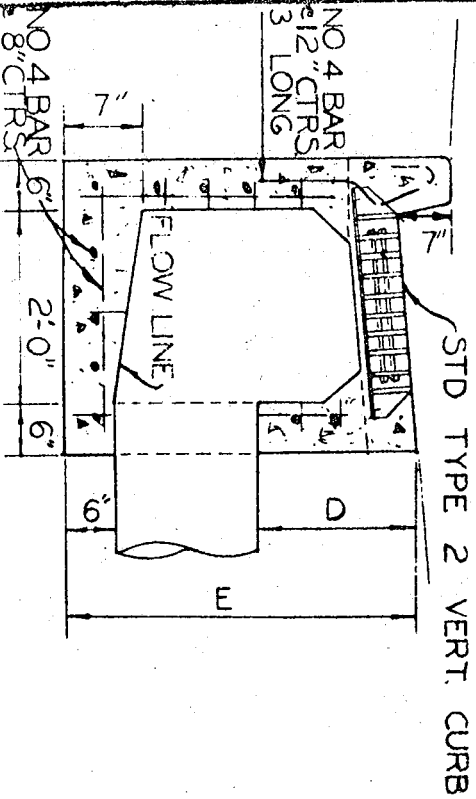

SECTION A-A

- NOTES:
1. DIMENSIONS D&E MAY VARY WITH EACH LOCATION
  2. ALL EXPOSED PARTS TO BE COATED WITH ASPHALT
  3. DEPRESSION IS STANDARD FOR ALL INLETS.
  4. SUMP IS OPTIONAL.

APPROVED :

*[Signature]*  
DIRECTOR OF PUBLIC WORKS

SACRAMENTO COUNTY  
DEPARTMENT OF PUBLIC WORKS  
HIGHWAY & BRIDGE DIVISION

DROP INLET

TYPE 2

Scale: NONE  
Date: APRIL 1, 1965  
Drawn By:

C-7

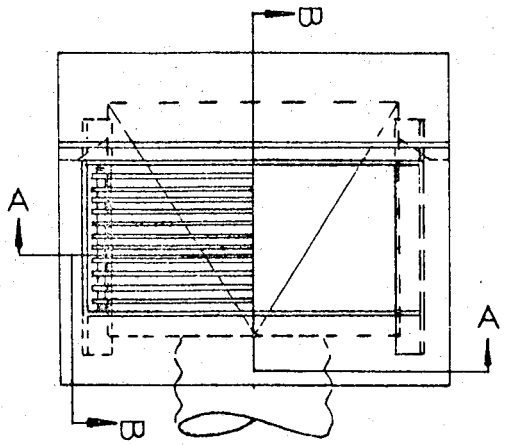

PLAN

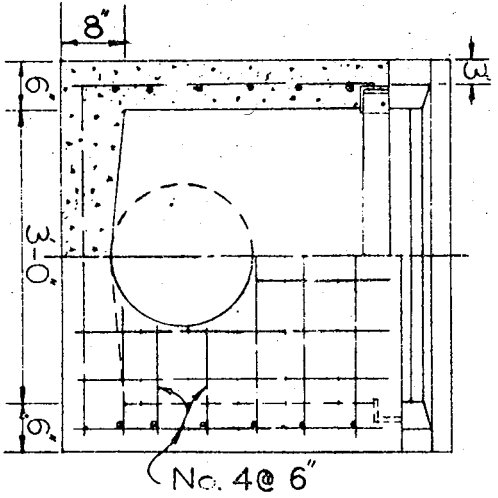

SECTION A-A

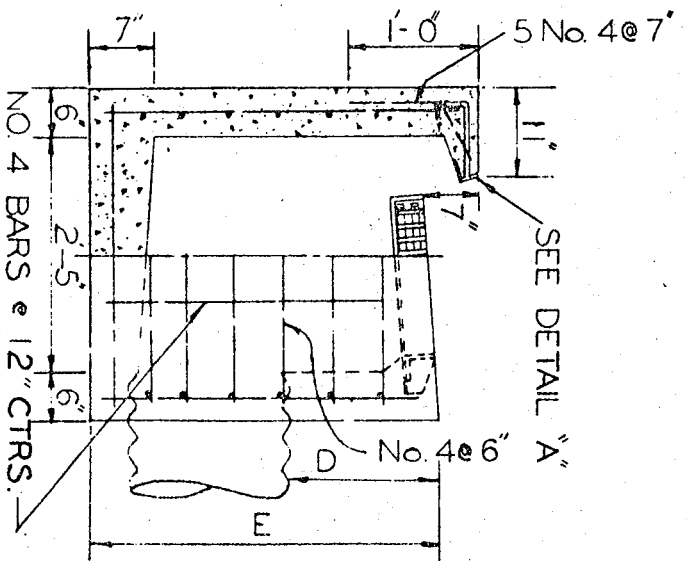

SECTION B-B

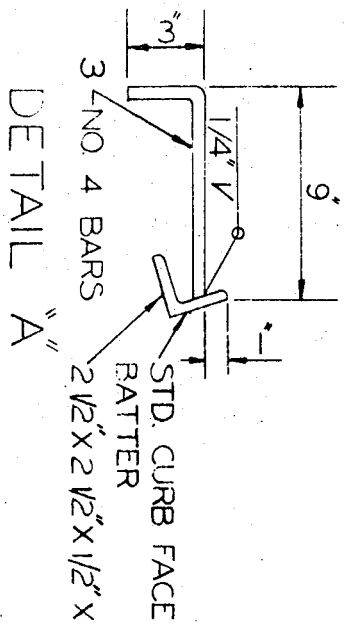

DETAIL "A"

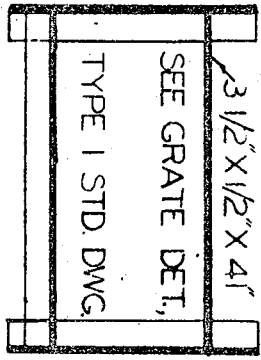

FRAME

NOTES:  
SEE TYPE 1 STANDARD DRAWING NOTES.

APPROVED: *A. E. Krieger*  
DIRECTOR OF PUBLIC WORKS

SACRAMENTO COUNTY DEPARTMENT OF PUBLIC WORKS HIGHWAY 8 BRIDGE DIVISION	
DROP INLET	
TYPE 3	
Scale: NONE	C-8
Date: APRIL 1, 1965	
Drawn By:	



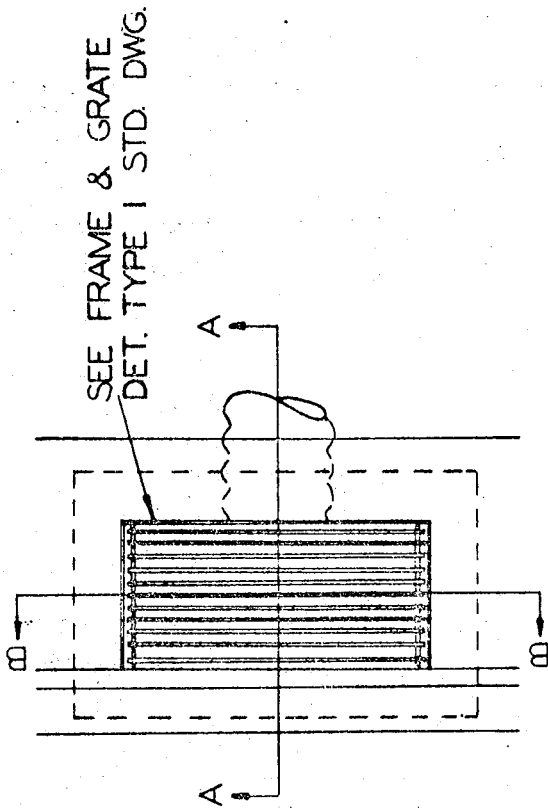

PLAN

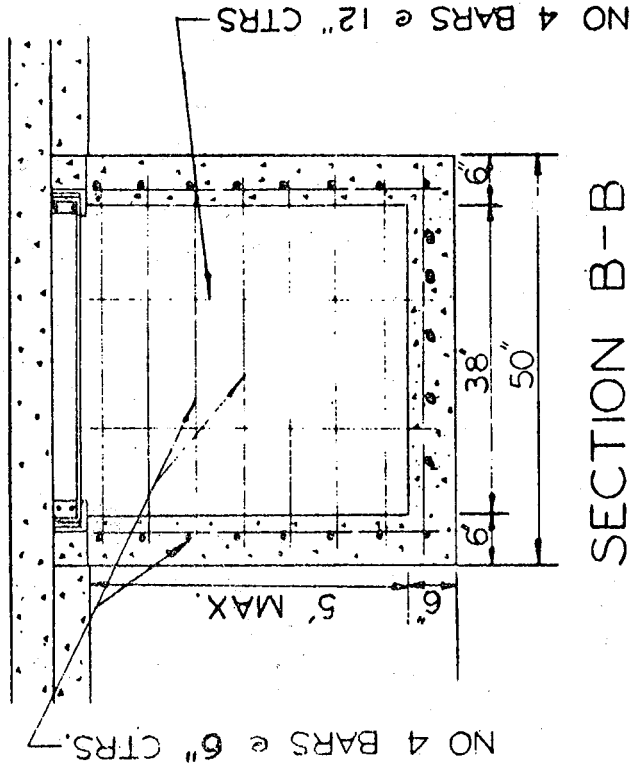

SECTION B-B

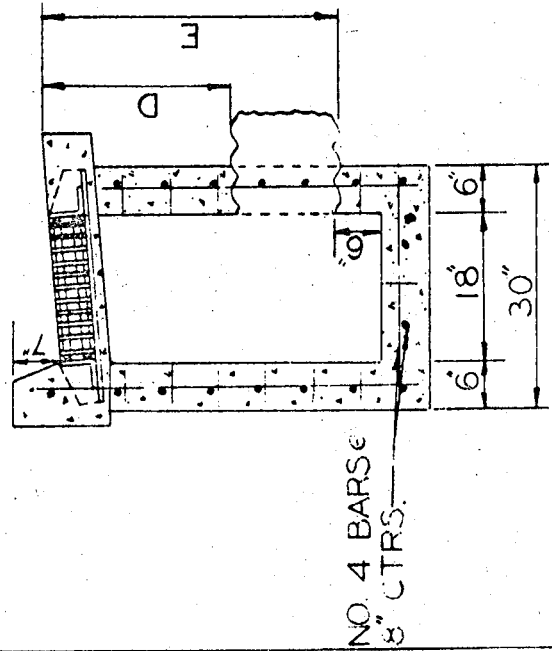

SECTION A-A

NOTES:  
SEE TYPE I STANDARD DRAWING  
NOTES.

SACRAMENTO COUNTY  
DEPARTMENT OF PUBLIC WORKS  
HIGHWAY & BRIDGE DIVISION

DROP INLET  
TYPE 4

Scale: NONE  
Date: APRIL, 1965  
Drawn By:

APPROVED:

*A. R. Kiefer*  
DIRECTOR OF PUBLIC WORKS

C-9

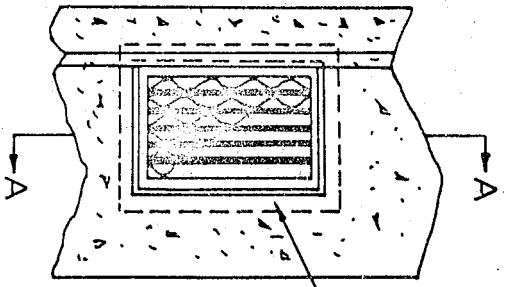

SEE DETAIL "B"

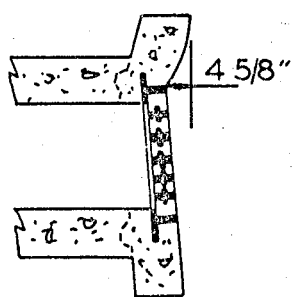

ALTERNATE "A"  
TYPE 1 ROLLED CURB

STD. AASHO BRIDGE DECKING  
2 1/2" X 3/16" BEARING BAR  
GALVANIZED AFTER  
FABRICATION

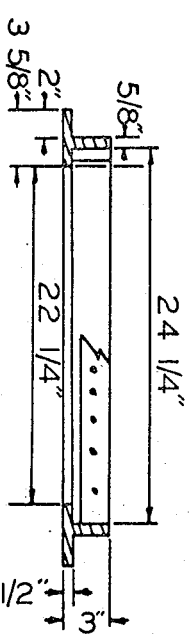
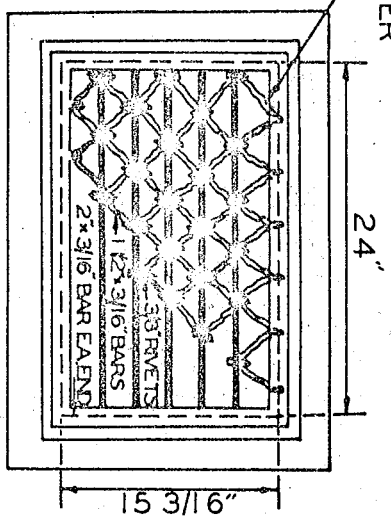
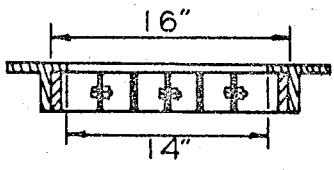

TYPE 2 VERTICAL CURB  
SEE ALTERNATE "A"

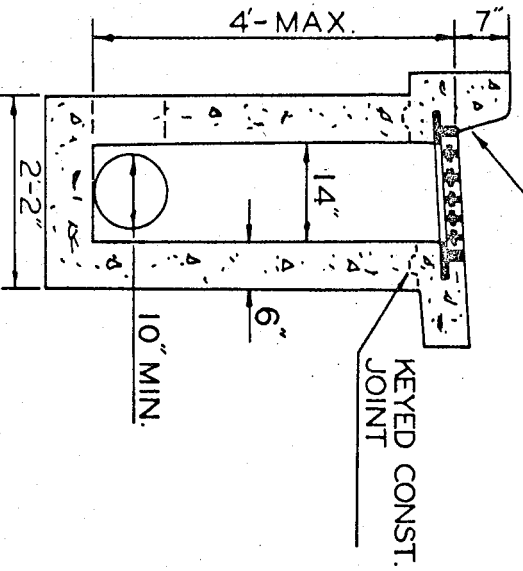

KEYED CONST.  
JOINT

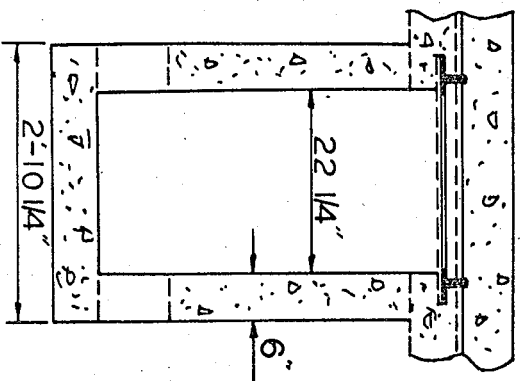

SECTION A-A

NOTES:

THIS STRUCTURE IS TO SERVE ONLY TO PICK UP GUTTER DRAINAGE OR AS A JUNCTION BOX FOR SMALL PIPES IN A LONGITUDINAL DIRECTION ONLY.

12" LENGTH OF 1/4" GALVANIZED CHAIN BE PERMANENTLY AFFIXED TO THE GRATE AND ONE CORNER OF THE INLET ADJACENT TO THE CURB.

STANDARD GUTTER DEPRESSION

APPROVED :

*A. Steiner*  
DIRECTOR OF PUBLIC WORKS

SACRAMENTO COUNTY  
DEPARTMENT OF PUBLIC WORKS  
HIGHWAY & BRIDGE DIVISION

DROP INLET

TYPE 5

Scale: NONE  
Date: APRIL 1 1965  
Drawn By:

C-10

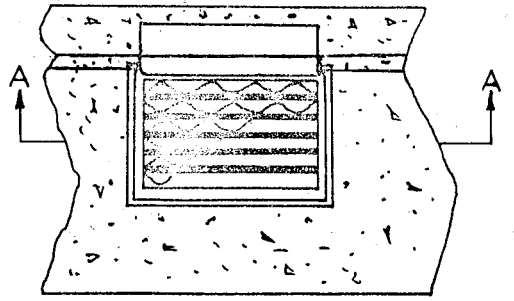

TYPE 2 VERTICAL CURB

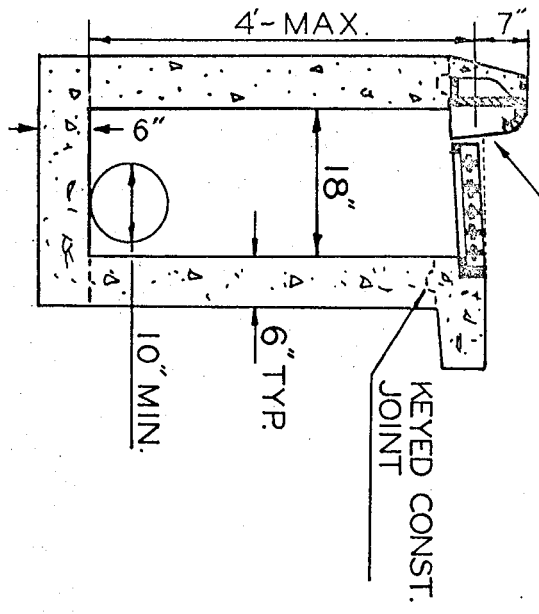

ALTERNATE "B"

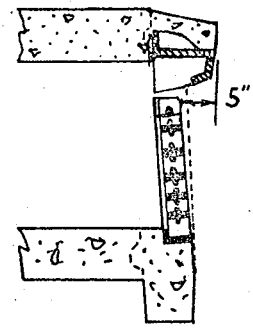

ALTERNATE "A"  
TYPE 1 ROLLED CURB  
WARP TO FIT CURB

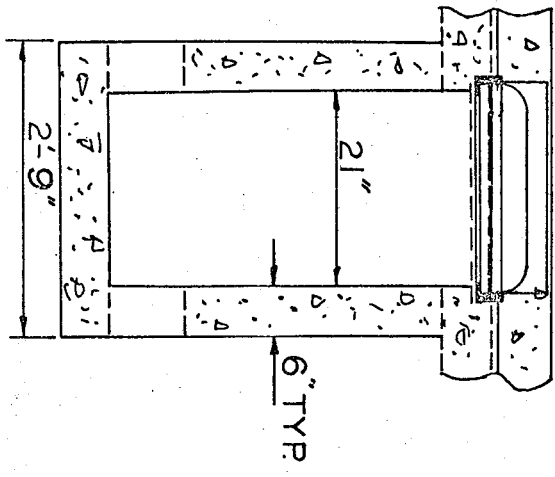

SECTION A-A

STD. ASHO BRIDGE DECKING  
2-1/2" X 3/16" BEARING BAR  
GALVANIZED AFTER  
FABRICATION  
FRAME TO BE FABRICATED  
FROM 3/4" X 2 1/2" ANGLES.  
JOINTS TO BE WELDED.

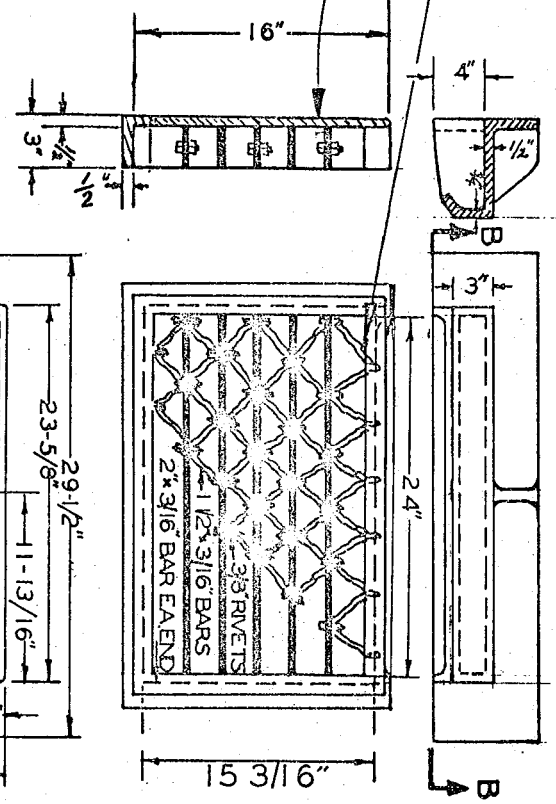

SECTION B-B

NOTES:  
THIS STRUCTURE IS TO SERVE ONLY TO PICK UP  
GUTTER DRAINAGE OR AS A JUNCTION BOX FOR  
SMALL PIPES IN A LONGITUDINAL DIRECTION ONLY.  
12" LENGTH OF 1/4" GALVANIZED CHAIN TO BE PER-  
MANENTLY AFFIXED TO THE GRATE AND ONE  
CORNER OF THE INLET ADJACENT TO THE  
CURB.  
STANDARD GUTTER DEPRESSION (EXCEPT ALTERNATE  
"A" TO BE DEPRESSED 1-3/8")

DROP INLET

TYPE 5A

SACRAMENTO COUNTY  
DEPARTMENT OF PUBLIC WORKS  
HIGHWAY & BRIDGE DIVISION

APPROVED: *A. R. [Signature]*  
DIRECTOR OF PUBLIC WORKS

REVISED 11-67

Scale: NONE  
Date: APRIL 1 1965  
Drawn By: C-10A

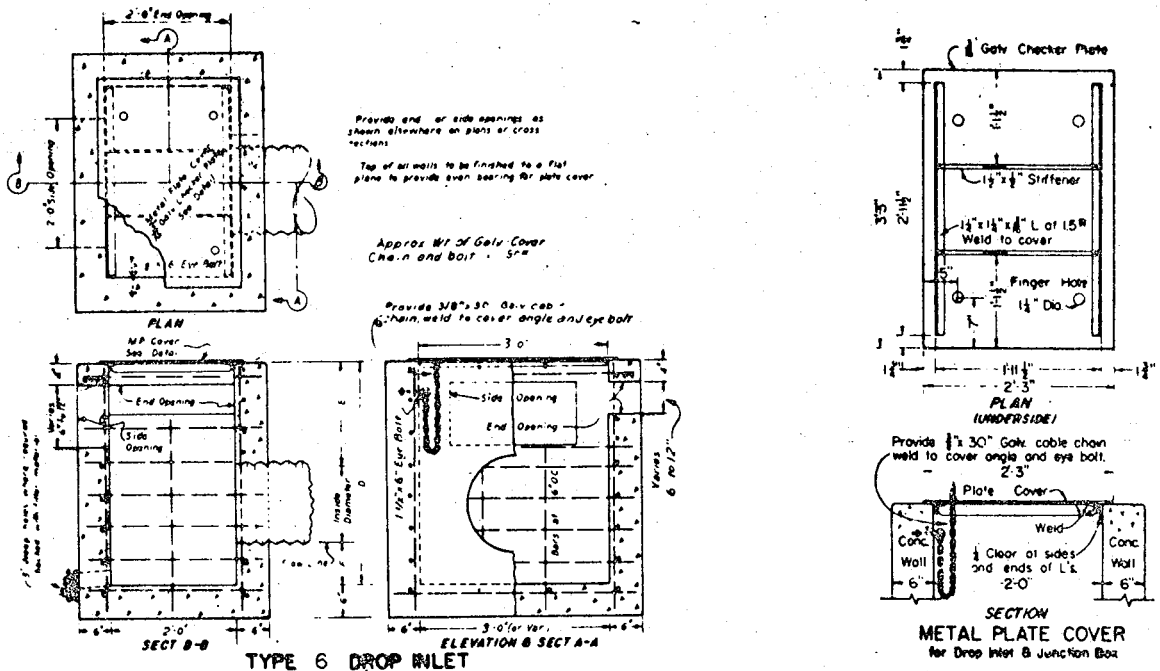

TYPE 6 DROP INLET

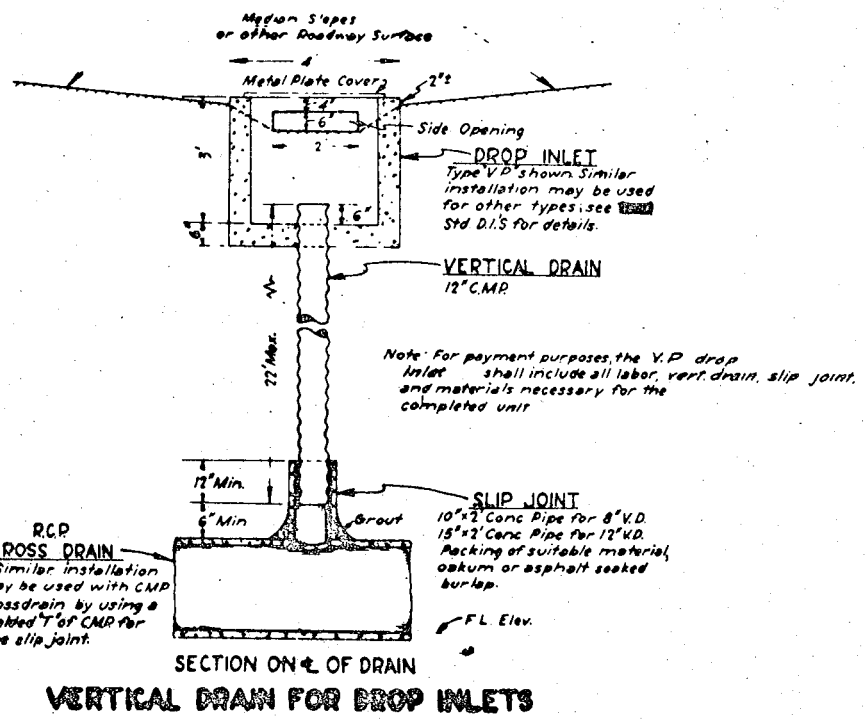

SECTION ON C OF DRAIN  
VERTICAL DRAIN FOR DROP INLETS

**DROP INLET CONSTRUCTION NOTES**

All reinforcing to be 1/2" deformed bars spaced as shown.  
 Length of Vertical Bars--1" clear each end.  
 Length of Horizontal Bars-- 1 1/2" clear each end.  
 Connecting pipe size & arrangement may vary for each location and are to be placed as shown elsewhere on plans and cross sections.  
 Dimension D, E, & F may vary with each location as shown elsewhere on plans and cross sections.  
 Wrap holes to be omitted where dimension "P" is less than 3" or where used as a slipbox.  
 All exposed metal parts to be coated with asphalt.  
 Where drainage from D.I.'s with curb or other vertical openings enters a depressed highway pumping plant, those openings shall be barred with 1/4" vertical bars spaced at 5" to 6" centers. Bars to be installed as shown elsewhere on these plans, or as directed by the Engineer.

SACRAMENTO COUNTY DEPARTMENT OF PUBLIC WORKS HIGHWAY & BRIDGE DIVISION	
DROP INLET TYPE 6	
Scale: NONE Date: APRIL 1, 1965 Drawn By:	C-11

APPROVED: *[Signature]*  
 DIRECTOR OF PUBLIC WORKS

STD. AASHO BRIDGE  
DECKING GRATE SEE  
TYPE 5 STD. DWGS.

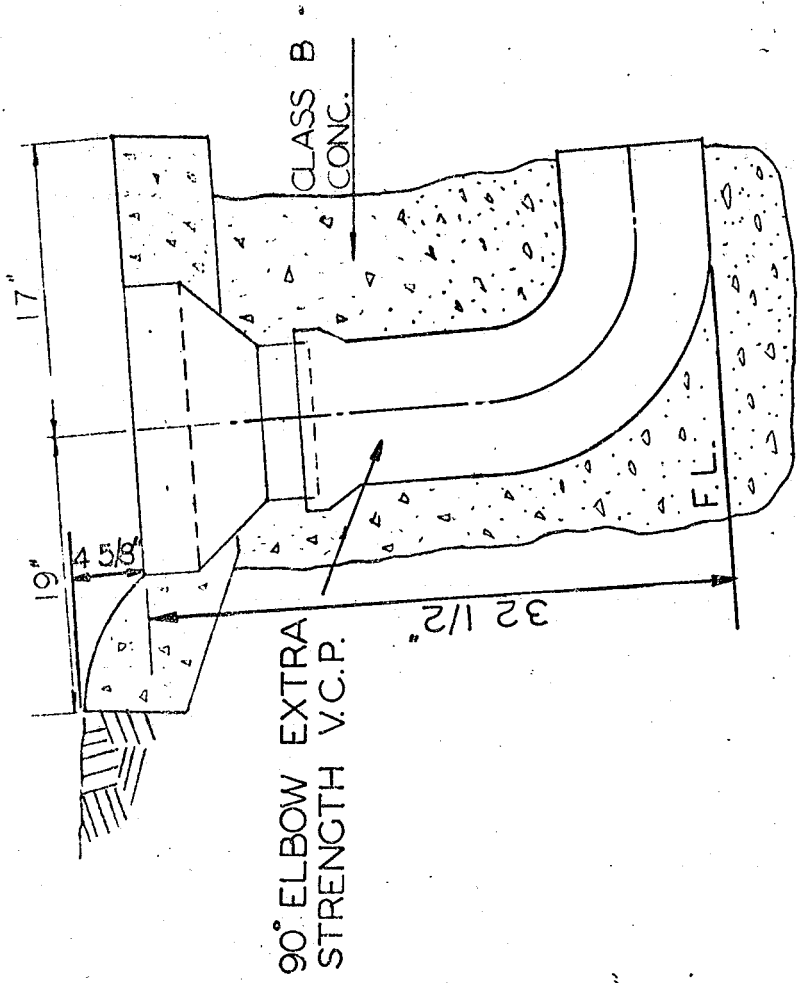
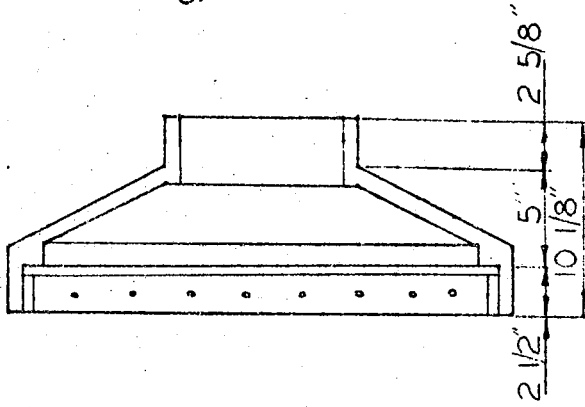
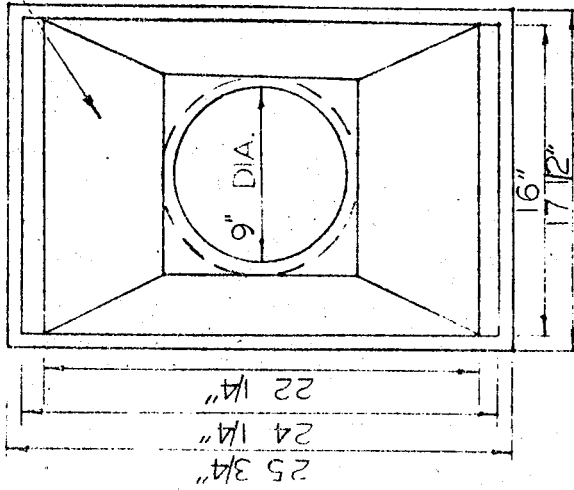

NOTE: THIS STRUCTURE TO BE USED ONLY TO PICK UP  
GUTTER DRAINAGE FOR SHORT RUNS INTO A MANHOLE  
OR OTHER LARGE APPROVED STRUCTURE.

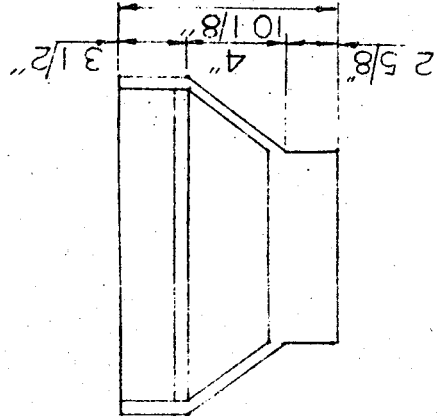

SACRAMENTO COUNTY  
DEPARTMENT OF PUBLIC WORKS  
HIGHWAY & BRIDGE DIVISION

GUTTER DRAIN

Scale: NONE  
Date: APRIL 1, 1965  
Drawn By:

APPROVED: *A. E. Kiefer*  
DIRECTOR OF PUBLIC WORKS

C-12

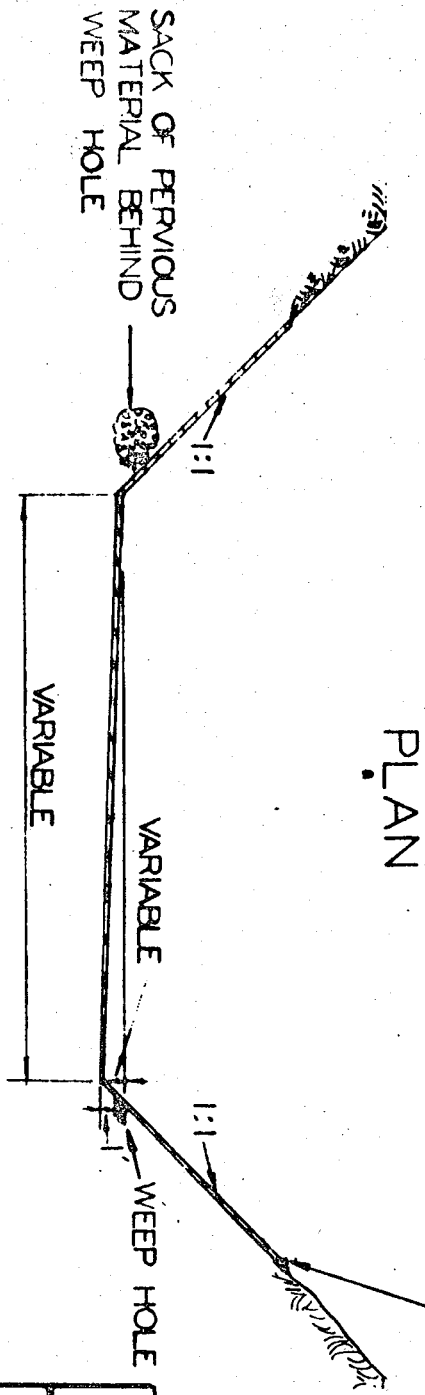
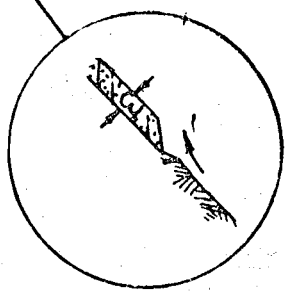
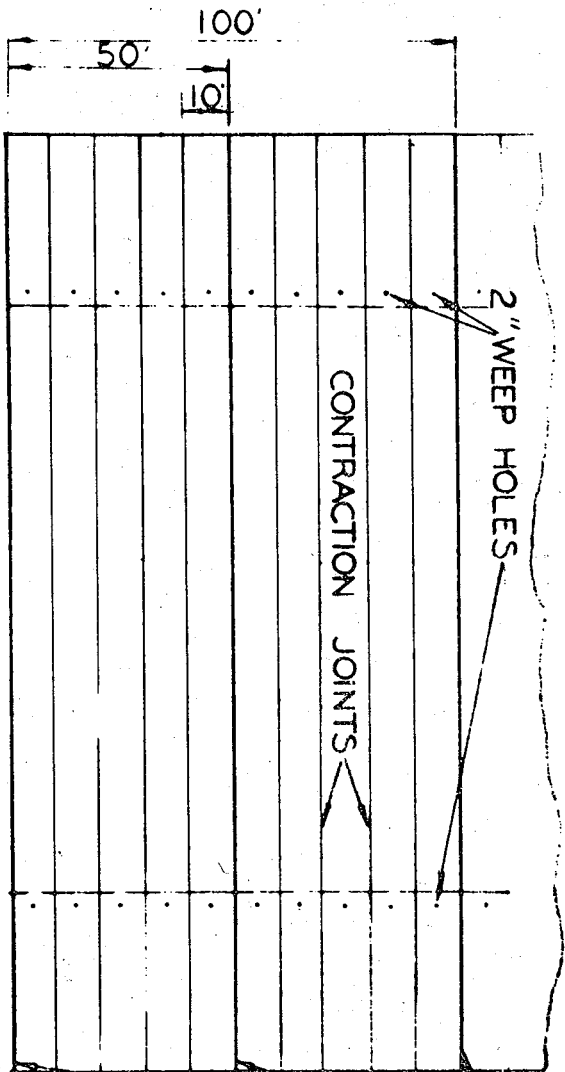

PLAN

SECTION

APPROVED: *A. R. [Signature]*  
DIRECTOR OF PUBLIC WORKS

REVISID 8-66

SACRAMENTO COUNTY  
DEPARTMENT OF PUBLIC WORKS  
HIGHWAY & BRIDGE DIVISION

LINED CHANNEL

SECTION

Scale: NONE  
Date: APRIL 1, 1965  
Drawn By:

C-13

TABLE OF DIMENSIONS

M.H	A	B	C	D	E	F	G	H	J	K
36	36	44	12	12	6	24	6	VARY	VARY	VARY
42	42	50	12	24	6	24	9	"	"	"
48	48	58	12	30	6	24	12	"	"	"
* 60	60	72	12	48	6	24	19.2	"	"	"

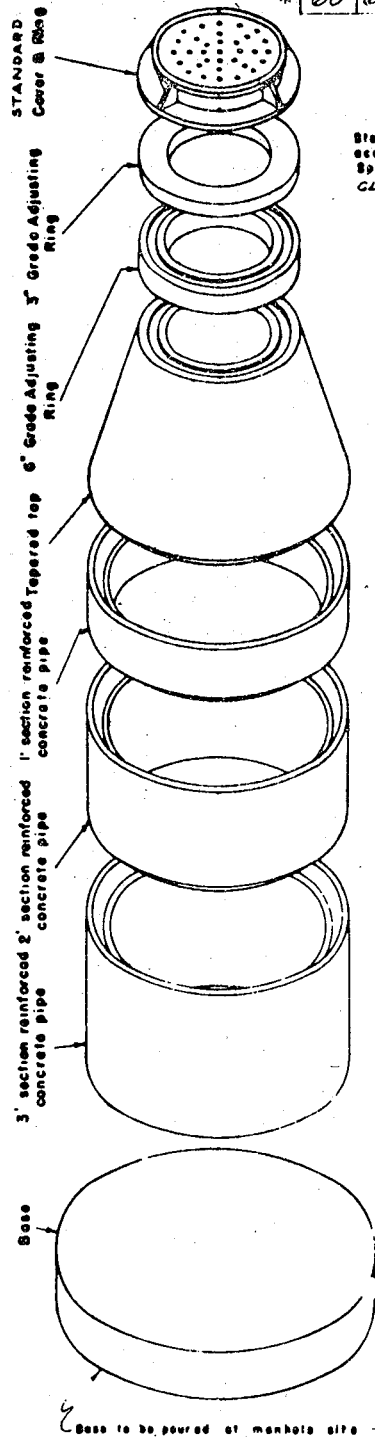

EXPLODED VIEW

Steel Reinforcement in accordance with A & E. Specification C-76-57T CLASS III

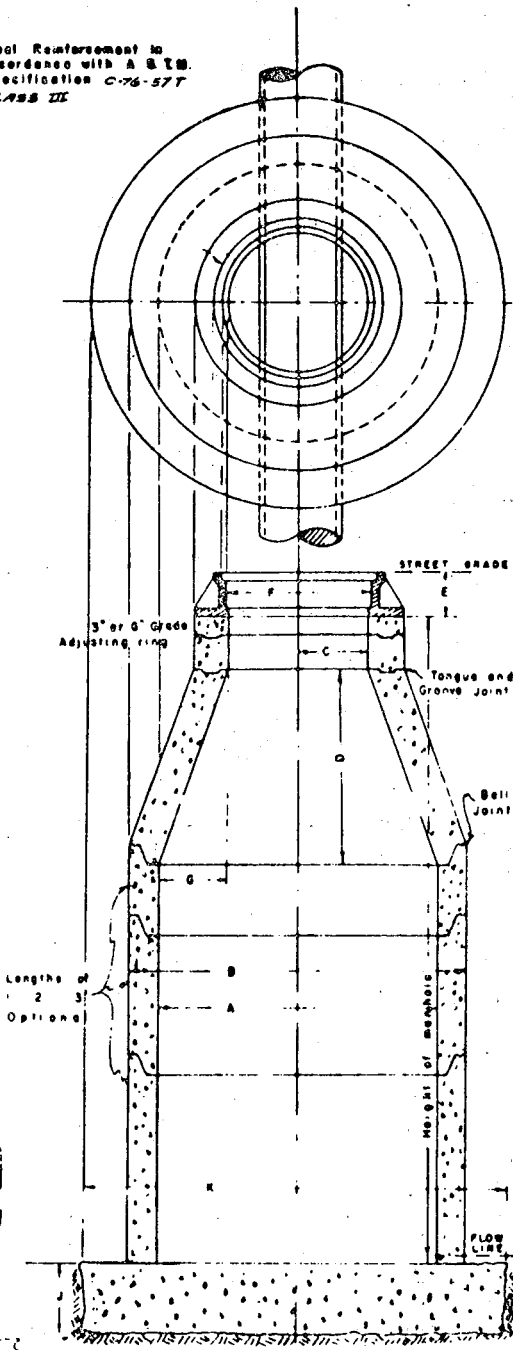

TYPICAL PRECAST CONCRETE MANHOLE

FOR PIPES 24" OR LESS IN DIAMETER CHANNELIZATION WILL BE REQUIRED AS SHOWN ON STANDARD DRWG. 310-5-2

\* 60"MH-"F" MAY BE 36" EXCEPT IN THE TRAVELED WAY.

APPROVED: *[Signature]*  
DIRECTOR OF PUBLIC WORKS

Scale  
Date  
Drawn By

C-14

SACRAMENTO COUNTY  
DEPARTMENT OF PUBLIC WORKS  
HIGHWAY & BRIDGE DIVISION  
PRECAST MANHOLE

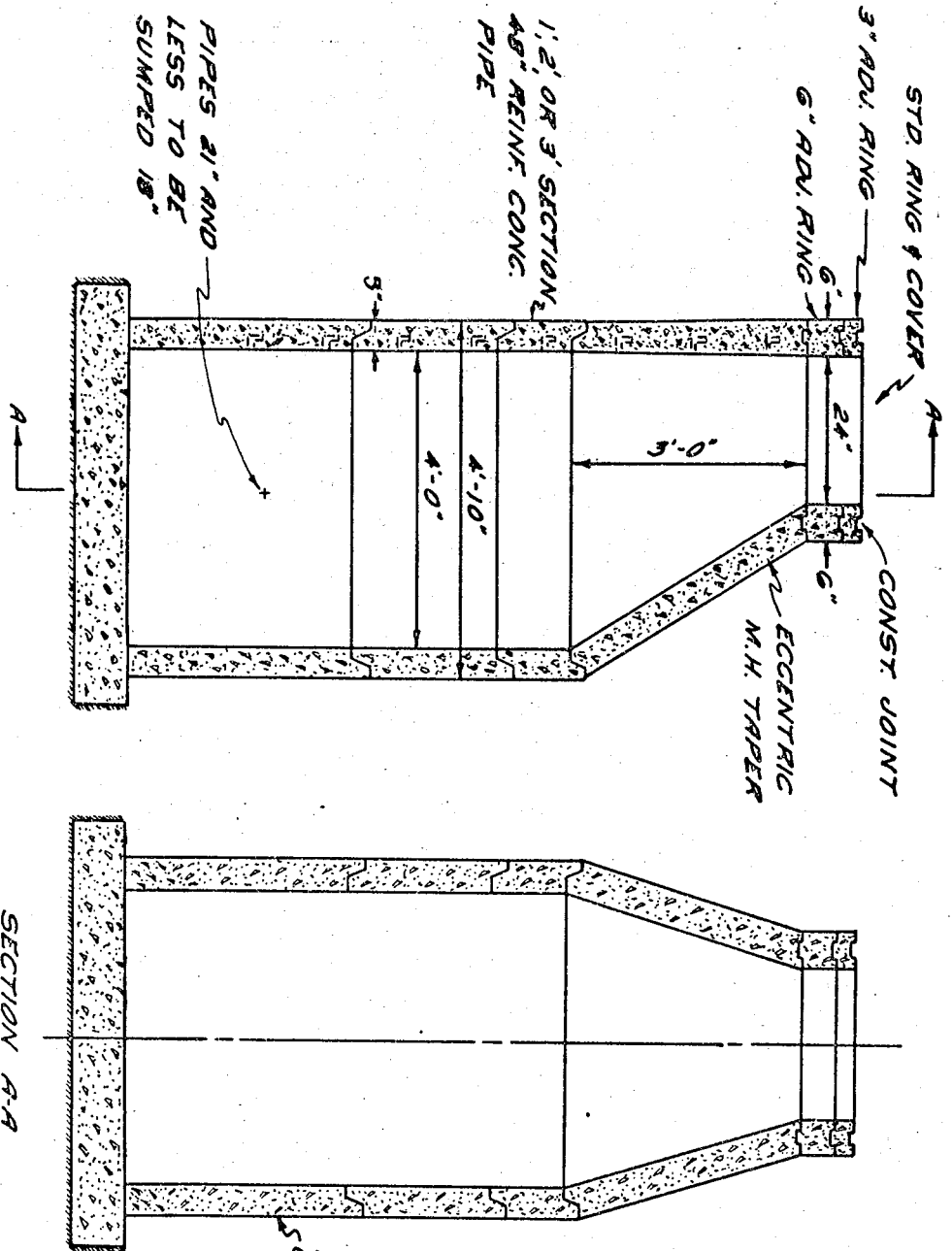

NOTES: 1. 48" DIAMETER  
MANHOLE SHOWN.  
2. ECCENTRIC CONE  
NOT AVAILABLE  
FOR 60" DIA. M.H.

ALL SECTIONS  
CLASS III RCCP ASTM C-76-97T

SECTION A-A

REDUCED

APPROVED: *R. P. [Signature]*  
DIRECTOR OF PUBLIC WORKS

SACRAMENTO COUNTY DEPARTMENT OF PUBLIC WORKS HIGHWAY & BRIDGE DIVISION	
PRECAST MANHOLE WITH ECCENTRIC CONE	
Scale: NONE Date: 7-1-60 Drawn By: JJS	C-15



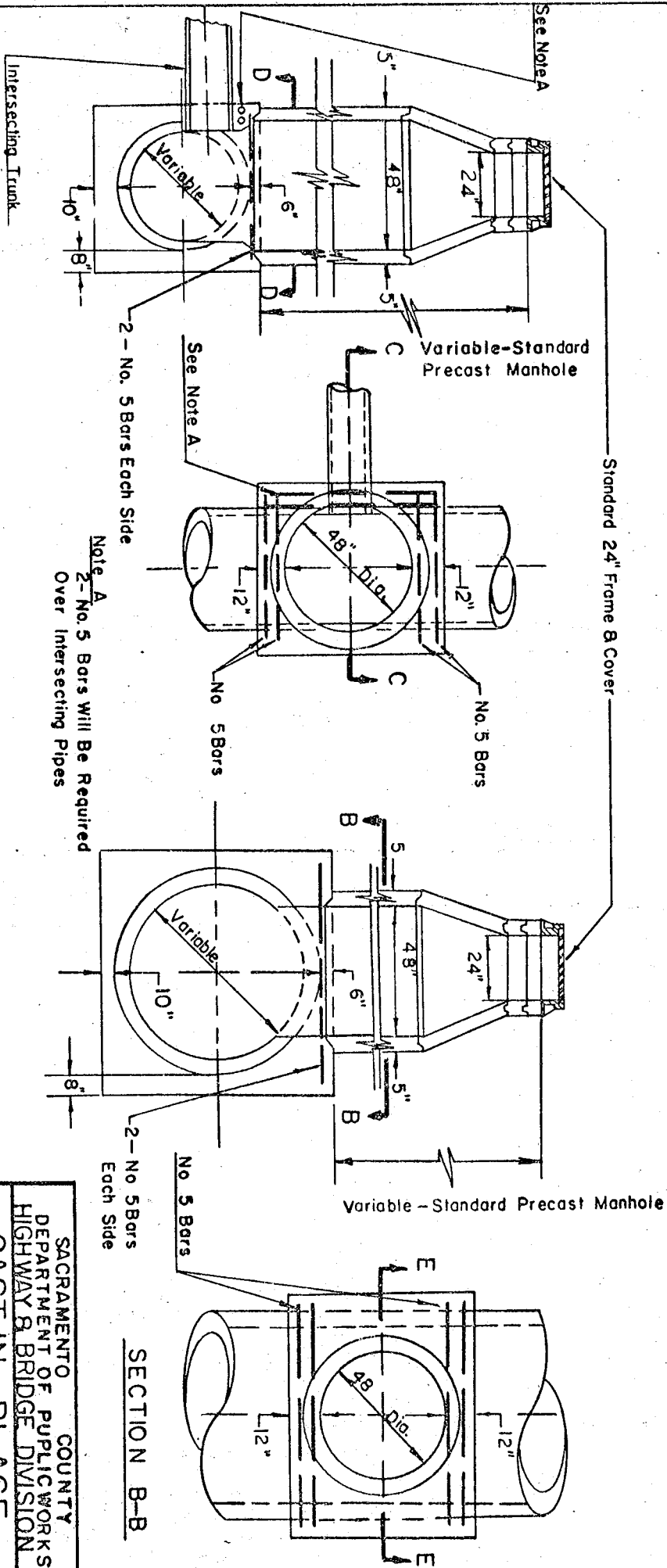

SECTION C-C

SECTION D-D

SECTION E-E

SECTION B-B

APPROVED:

*A. R. [Signature]*  
DIRECTOR OF PUBLIC WORKS

SACRAMENTO COUNTY	
DEPARTMENT OF PUBLIC WORKS	
HIGHWAY & BRIDGE DIVISION	
CAST IN PLACE	
SADDLE TYPE	
MANHOLE	
Scale	C-16
Date	4-23-63
Drawn By	

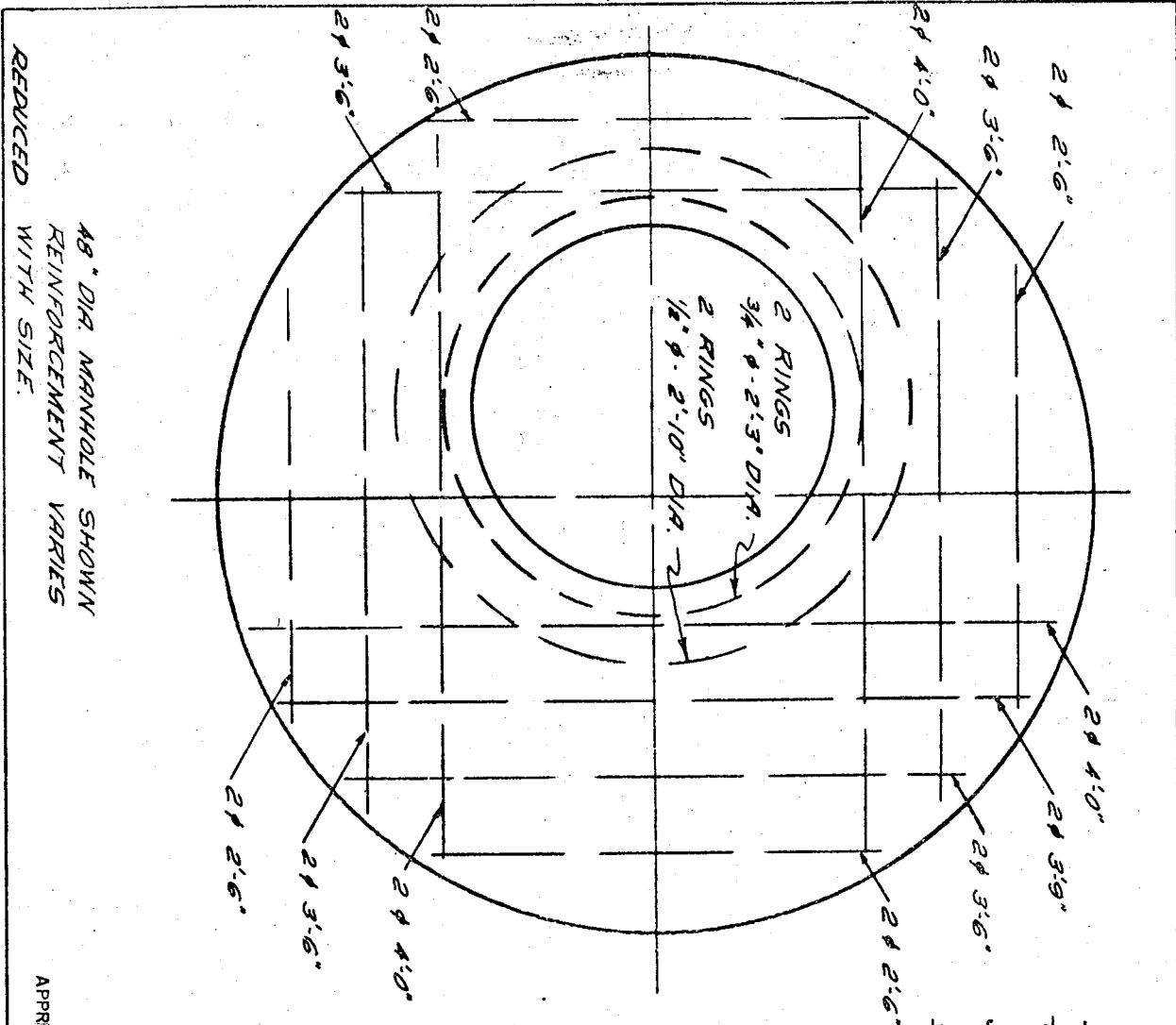

48" DIA. MANHOLE SHOWN  
 REINFORCEMENT VARIES  
 WITH SIZE.  
 REDUCED

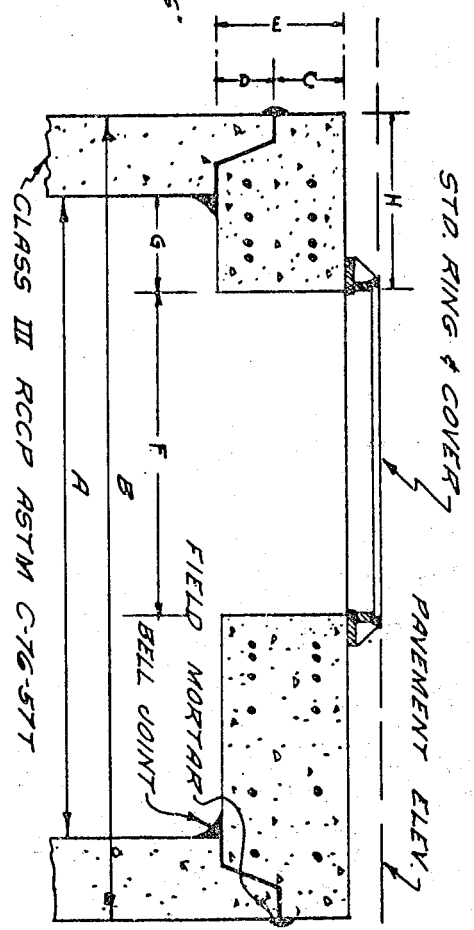

TABLE OF DIMENSIONS

Particular Size	A	B	C	D	E	F	G	H
42	42"	30"	4 1/2"	3 3/4"	3"	2 1/2"	6"	10"
48	48"	36"	4 3/4"	4 1/4"	3 1/2"	2 3/4"	6"	11"
60	60"	42"	4 3/4"	4 3/4"	3 3/4"	3"	6"	12"

- NOTES: 1. OPENING MAY BE PLACED IN CENTER.  
 2. LID NOT PRACTICAL FOR 36" MANHOLE ASSEMBLY.  
 3. ALL STEEL 1/2" DEFORMED BARS UNLESS OTHERWISE NOTED.  
 4. ALL STEEL TO HAVE 1/2" CLEARANCE.  
 5. TO BE USED ONLY WHEN DEPTH DOES NOT PERMIT USE OF TAPER UNIT.

APPROVED: *A. P. [Signature]*  
 DIRECTOR OF PUBLIC WORKS

SACRAMENTO COUNTY  
 DEPARTMENT OF PUBLIC WORKS  
 HIGHWAY & BRIDGE DIVISION

REINF. CONC. LID FOR  
 PRECAST MANHOLE

Scale: NONE  
 Date: 11-1-60  
 Drawn By: CMW

C-17

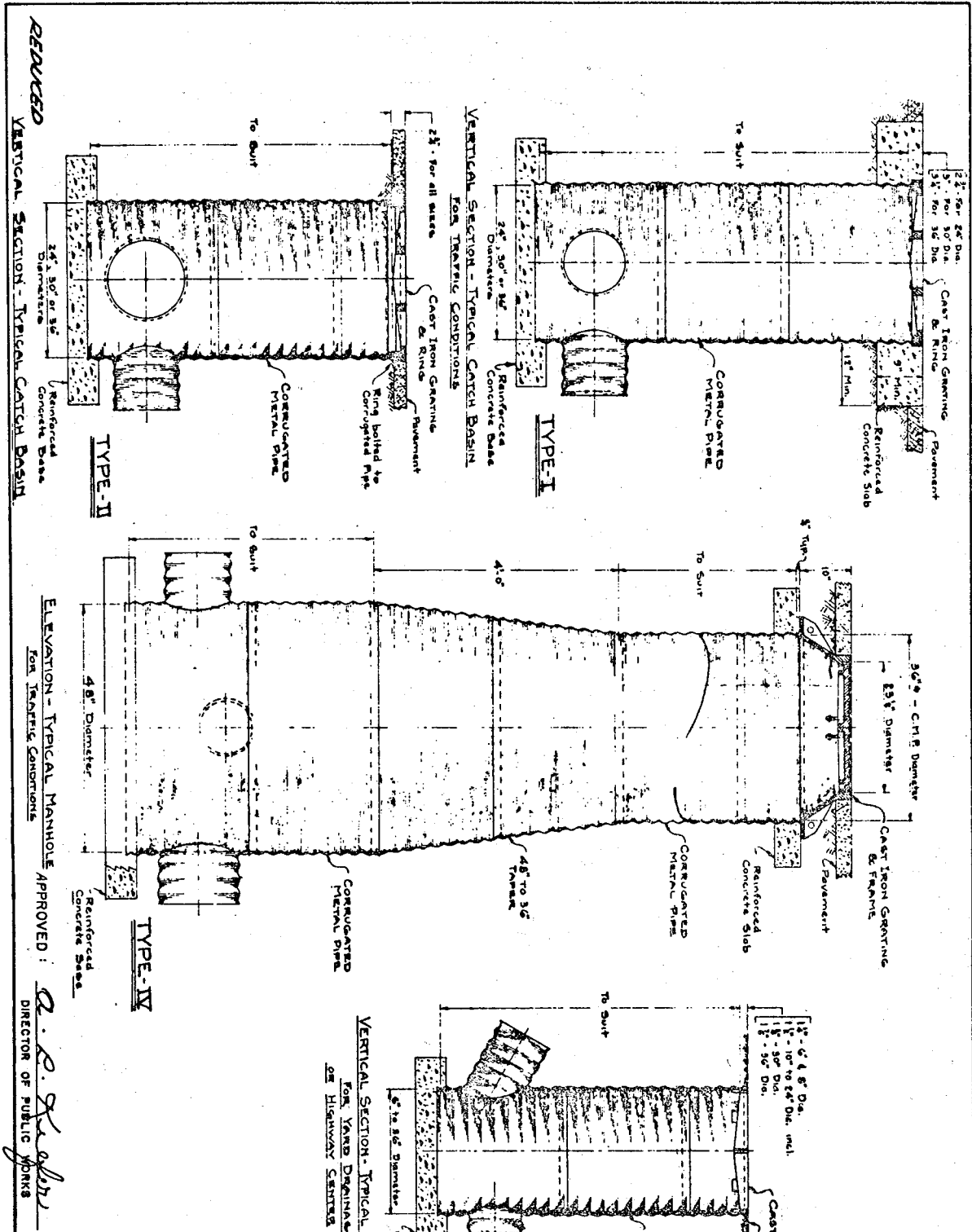

REMOVED  
 VERTICAL SECTION - TYPICAL CATCH BASIN

ELEVATION - TYPICAL MANHOLE APPROVED FOR TRAFFIC CONDITIONS  
 A. E. Schuler  
 DIRECTOR OF PUBLIC WORKS

SACRAMENTO COUNTY DEPARTMENT OF PUBLIC WORKS HIGHWAY & BRIDGE DIVISION	
PREFABRICATED STEEL MANHOLE	
Scale: <i>AS SHOWN</i>	C-18
Date: 1-1-60 Drawn By: <i>WINGCO</i>	

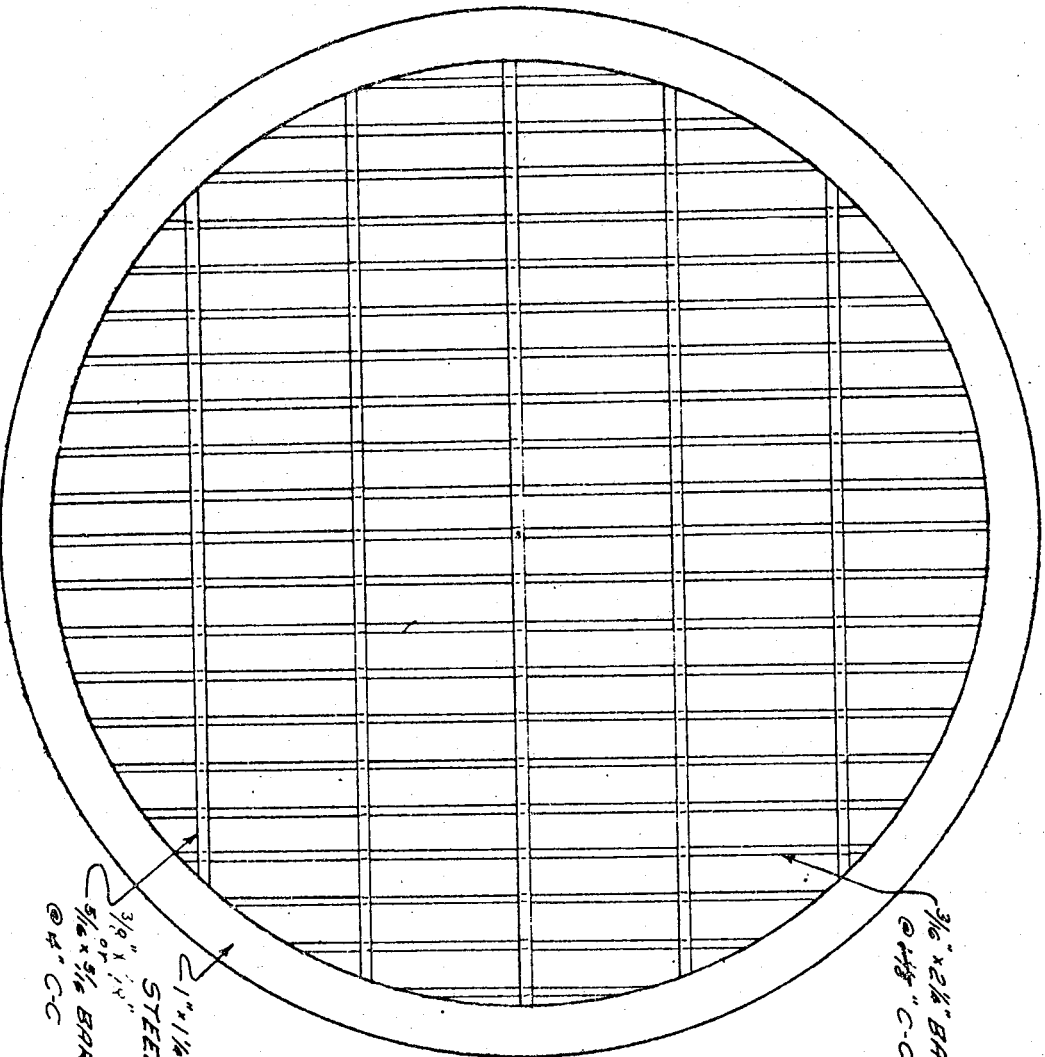

3/16" x 2 1/2" BARS  
@ 1 1/8" C-C

2 1/4" x 1 1/4" ROLLED  
STEEL RING  
3/16" x 1 1/2"  
5/16" x 5/16" BARS  
@ 1/2" C-C

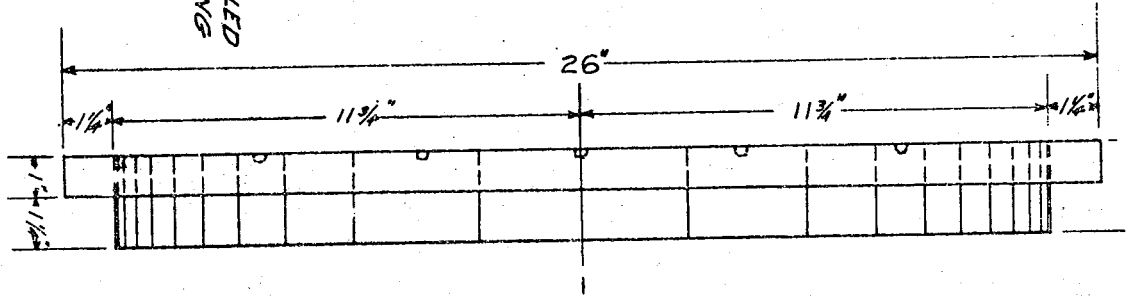

SUPERWEELD - SW 225  
IRVING TYPE - IW AT5  
OR EQUAL  
GALVANIZE AFTER FABRICATION  
REDUCED

APPROVED: *D. R. [Signature]*  
DIRECTOR OF PUBLIC WORKS

SACRAMENTO COUNTY  
DEPARTMENT OF PUBLIC WORKS  
HIGHWAY & BRIDGE DIVISION

GRATE TYPE  
MANHOLE COVER

Scale: NONE  
Date: 1-1-60  
Drawn By:

C-19

SACRAMENTO COUNTY  
DEPARTMENT OF PUBLIC WORKS  
HIGHWAY & BRIDGE DIVISION

TRASH RACK

Scale: NONE  
Date: 1-1-60  
Drawn By:

APPROVED: *A. R. X. X. X.*  
DIRECTOR OF PUBLIC WORKS

C-20

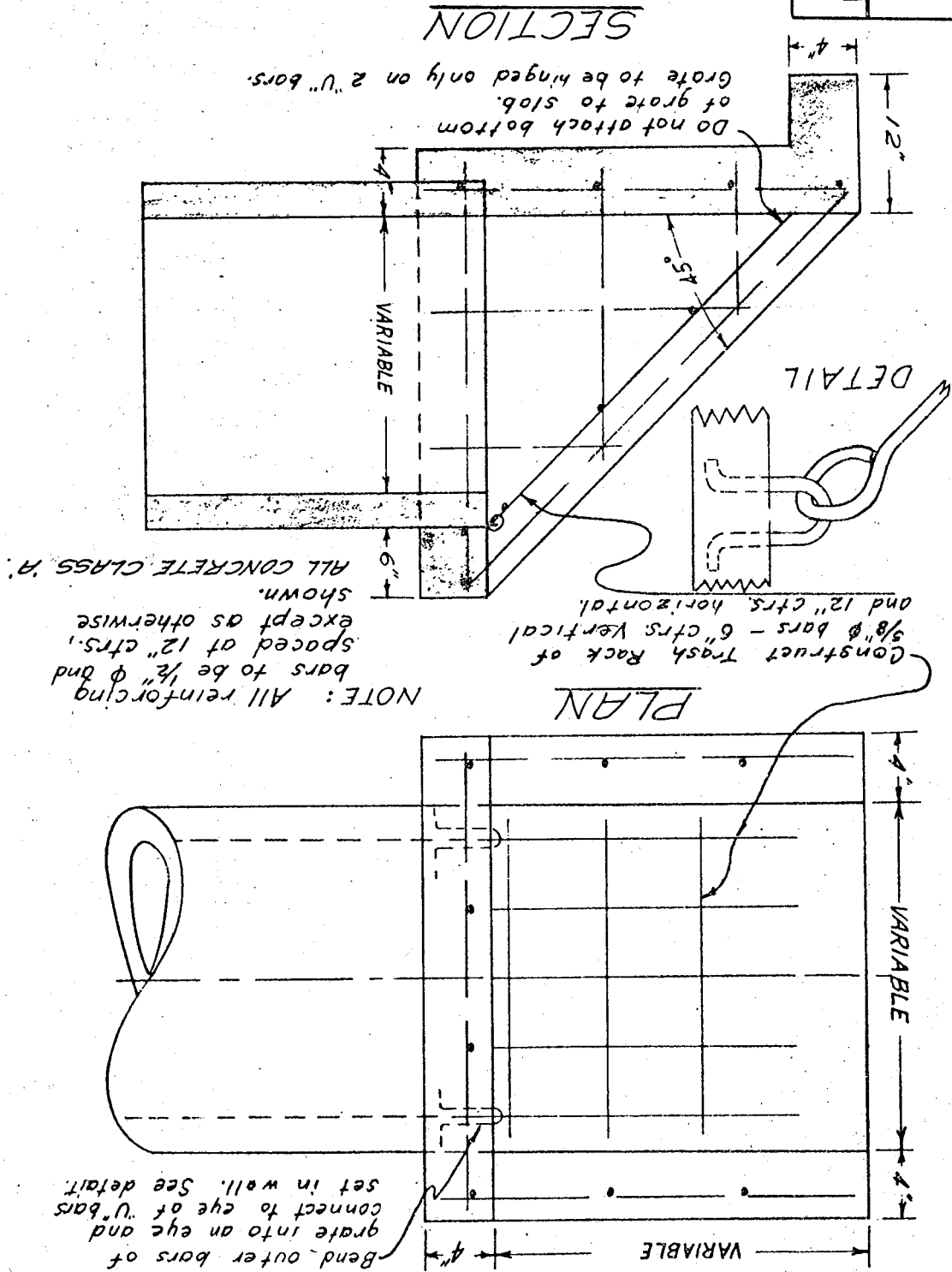

REDUCED

REDUCED

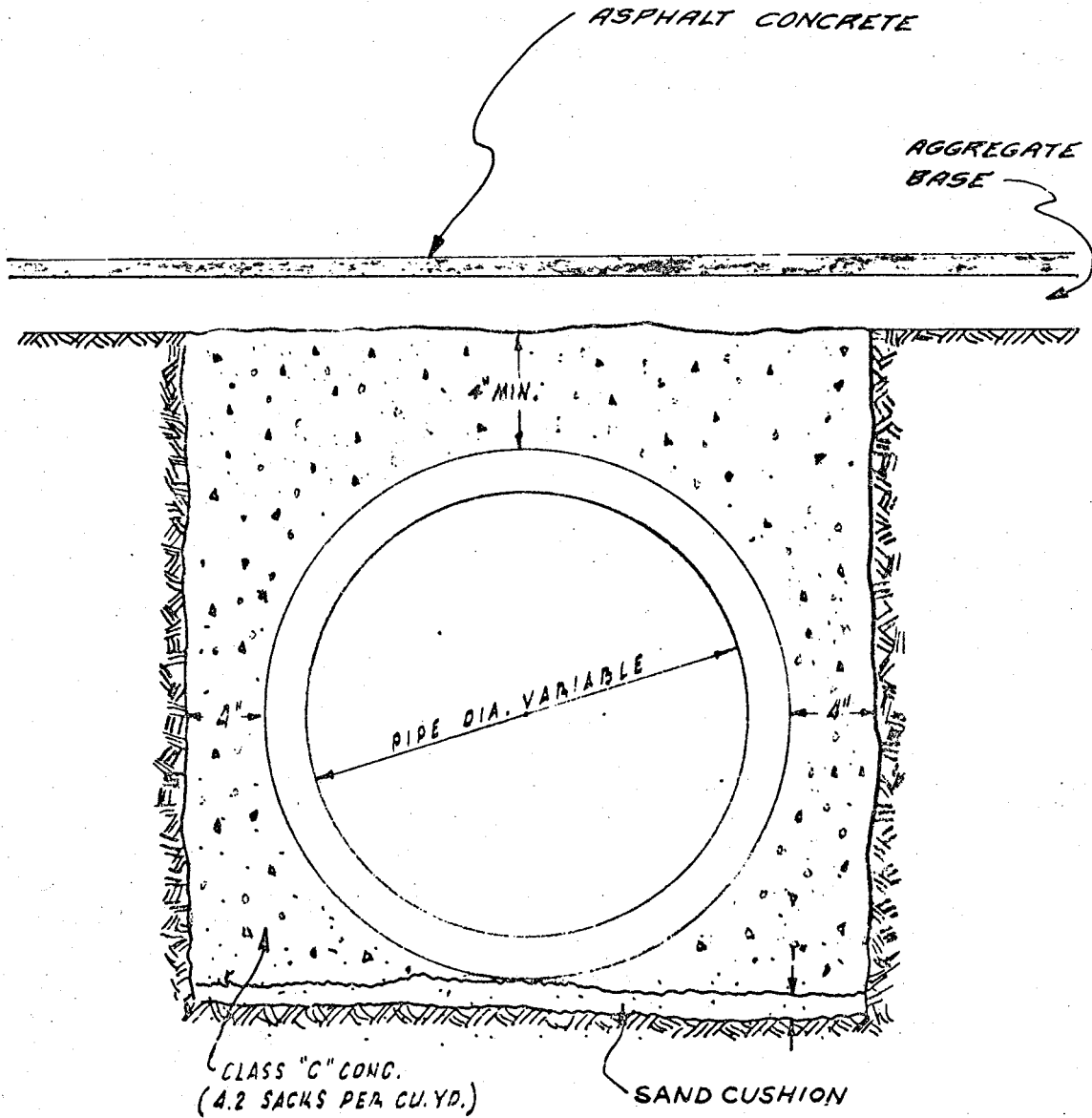

APPROVED :

*A. P. Stebbins*  
DIRECTOR OF PUBLIC WORKS

SACRAMENTO COUNTY DEPARTMENT OF PUBLIC WORKS HIGHWAY & BRIDGE DIVISION	
CONCRETE PIPE ENCASEMENT	
Scale: NONE Date: 1-1-60 Drawn By:	C-21

REDUCED

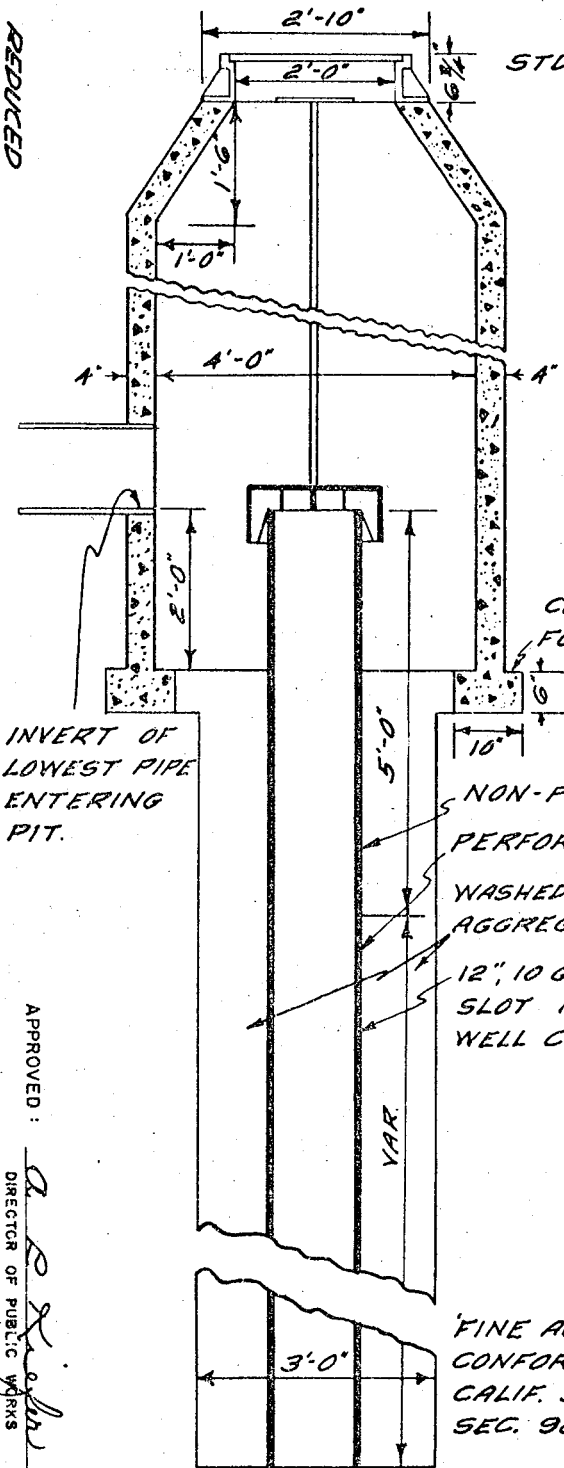

STD. M.H. COVER

AIR HOLES

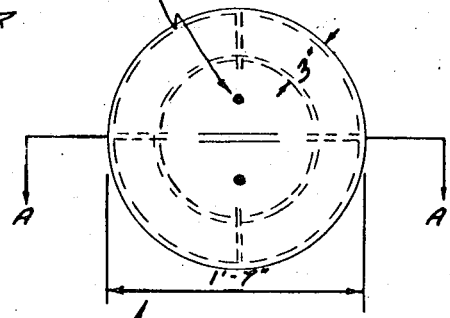

COVER FOR WELL CASING TO BE FABRICATED FROM 1/4" STEEL PLATE. ALL JOINTS TO BE WELDED.

CONCRETE FOOTING

INVERT OF LOWEST PIPE ENTERING PIT.

NON-PERFORATED  
PERFORATED  
WASHED FINE AGGREGATE  
12", 10 GA., CHISEL SLOT PERFORATED WELL CASING

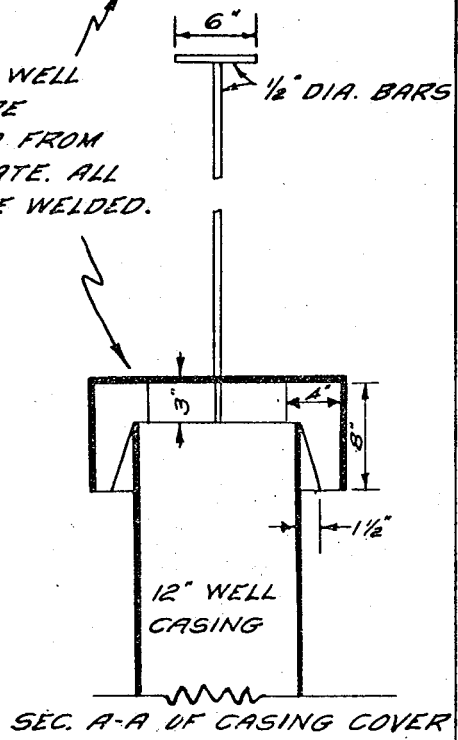

SEC. A-A OF CASING COVER

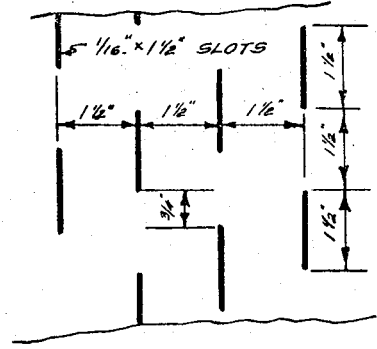

SECTION OF PERFORATED WELL CASING.

FINE AGGREGATE TO CONFORM TO 1960 CALIF. STD. SPEC'S, SEC. 90.

PIT TO BE DUG 10' INTO FIRST GRAVEL STRATA

APPROVED: *A. S. [Signature]*  
DIRECTOR OF PUBLIC WORKS

Scale: NONE  
Date: 1-1-60  
Drawn By:

SACRAMENTO COUNTY  
DEPARTMENT OF PUBLIC WORKS  
HIGHWAY & BRIDGE DIVISION  
DRAINAGE WELL

C-22

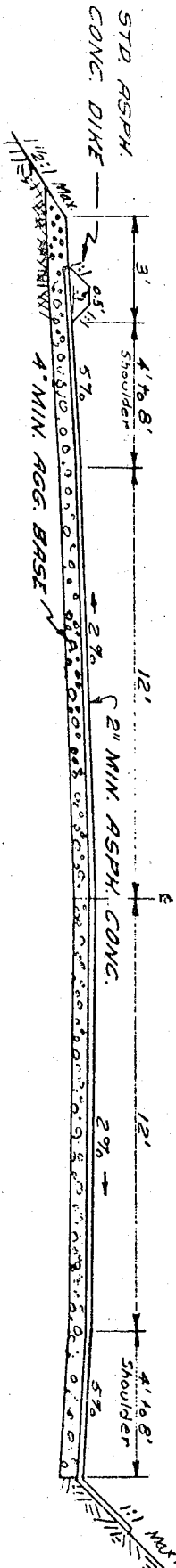

## TYPICAL EROSION CONTROL, CLASS C STREET

NOTE:

MAX. DEPTH	1.5%	2.0%	2.5%	3.0%	3.5%	4.0%	4.5%	5.0%	5.5%	6.0%
1.0	3.51 FS	4.09 FS	4.46 FS	5.02 FS	5.42 FS	5.82 FS	6.15 FS	6.48 FS	6.74 FS	7.1 FS
0.9	3.29 FS	3.36 FS	4.30 FS	4.73 FS	5.10 FS	5.46 FS	5.78 FS	6.10 FS	6.40 FS	6.69 FS
0.8	3.52 FS	3.74 FS	3.92 FS	4.30 FS	4.65 FS	4.99 FS	5.32 FS	5.55 FS	5.83 FS	6.10 FS
0.7	2.70 FS	3.17 FS	3.53 FS	3.83 FS	4.19 FS	4.49 FS	4.75 FS	5.00 FS	5.25 FS	5.47 FS
0.6	2.47 FS	2.89 FS	3.22 FS	3.54 FS	3.82 FS	4.09 FS	4.33 FS	4.57 FS	4.79 FS	5.01 FS
0.5	2.23 FS	2.61 FS	2.90 FS	3.19 FS	3.43 FS	3.66 FS	3.88 FS	4.08 FS	4.28 FS	4.47 FS
0.4	1.90 FS	2.22 FS	2.46 FS	2.70 FS	3.14 FS	3.17 FS	3.29 FS	3.50 FS	3.65 FS	3.80 FS
0.3	1.49 FS	1.74 FS	1.94 FS	2.13 FS	2.31 FS	2.48 FS	2.61 FS	2.73 FS	2.85 FS	2.97 FS
0.2	1.19 FS	1.39 FS	1.54 FS	1.68 FS	1.82 FS	1.96 FS	2.07 FS	2.18 FS	2.28 FS	2.38 FS
0	1.12 CFS	1.14 CFS	1.15 CFS	1.17 CFS	1.18 CFS	1.20 CFS	1.21 CFS	1.22 CFS	1.23 CFS	1.24 CFS

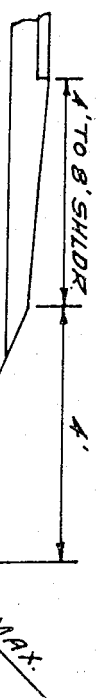

- 1-NO UNPROTECTED DITCHES WILL BE PERMITTED ALONG STREETS OF MORE THAN 5% GRADE.
- 2-MAXIMUM WATER DEPTH SHALL BE 0.7 FEET.
- 3-EARTH DITCH SHALL NOT EXCEED LINE "A" ON CHART, IF SOIL IS SANDY LOAM.
- 4-EARTH DITCH SHALL NOT EXCEED LINE "B" ON CHART, IF SOIL IS STIFF CLAY.
- 5-ALTERNATE DESIGNS FOR PROTECTION OF SHOULDERS, DITCHES, AND SLOPES ALONG STREETS WILL BE CONSIDERED IF CONDITIONS ARE UNUSUAL.

SACRAMENTO COUNTY  
DEPARTMENT OF PUBLIC WORKS  
HIGHWAY & BRIDGE DIVISION

EROSION CONTROL  
FOR CLASS 'C' STREETS



REDUCED

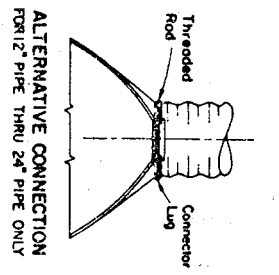

ALTERNATIVE CONNECTION FOR 12" PIPE THRU 24" PIPE ONLY

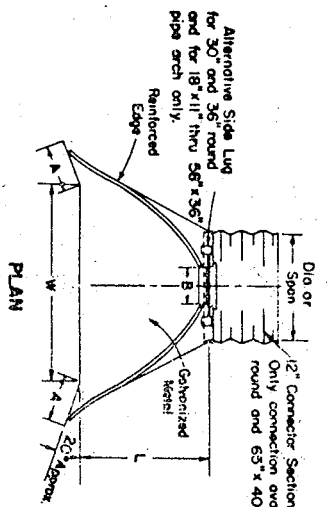

PLAN

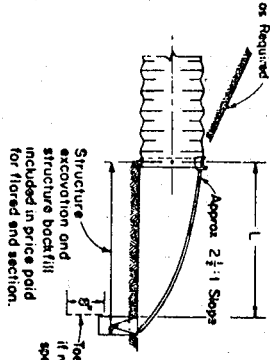

TYPICAL CROSS-SECTION

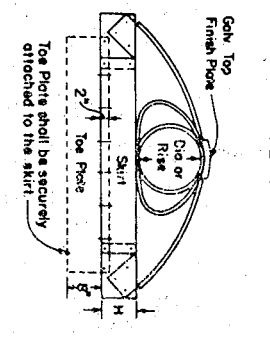

ELEVATION

PIPE DIAM.	DIMENSIONS - INCHES				
	GA	A	B	H	W
12"	16	4 1/2	6	6	21
15"	16	6	8	6	26
18"	16	7	9	6	31
21"	16	8 1/2	11	6	36
24"	14	9 1/2	12	6	42
30"	14	12	15	7 1/2	52 1/2
36"	12	14	18	9	63
42"	12	16	21	10 1/2	73 1/2
48"	12	18	27	12	84

INCHES	PIPE ARCHES				
	GA	A	B	H	W
Spoon Rise	16	4 1/2	6	6	21
18"	11	6	8	6	26
22"	13	8 1/2	11	6	31
25"	16	10 1/2	14	6	36
29"	18	12 1/2	17 1/2	6	42
35"	22	16	21	7 1/2	52 1/2
43"	27	20	26	9	63
50"	31	24	31	10 1/2	73 1/2
58"	36	28	36	12	84
65"	40	32	41	14	96
72"	44	36	46	16	108

FLARED END SECTIONS FOR C.M.P. CULVERTS

NOTES

- Connector section, corner plate and toe plate to be same gage as skirt.
- Length of toe plate
- If required by special provisions
- W + 10" for pipe dia. 12" to 30" incl.
- W + 22" for pipe dia. 36" to 48" incl.
- W + 10" for pipe arch rise 11" to 27" incl.
- W + 18" for pipe arch rise 31" to 44" incl.

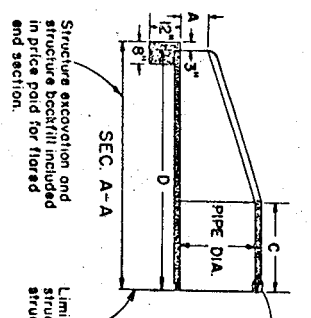

SEC. A-A

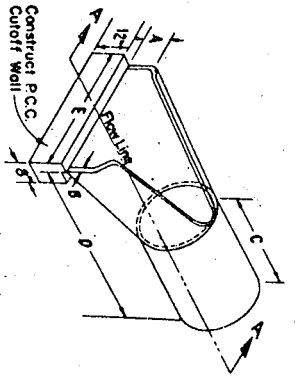

MINIMUM DIMENSIONS

MINIMUM DIMENSIONS	A	B	C	D	E
12"	4	1 1/2	2	2	0
15"	4	2	2	2	0
18"	4	2 1/2	2	2	0
21"	4	3	2	2	0
24"	4	3 1/2	2	2	0
30"	4	4 1/2	2	2	0
36"	4	5 1/2	2	2	0
42"	4	6 1/2	2	2	0
48"	4	7 1/2	2	2	0
54"	4	8 1/2	2	2	0
60"	4	9 1/2	2	2	0
66"	4	10 1/2	2	2	0
72"	4	11 1/2	2	2	0

PRECAST CONCRETE FLARED END SECTION

APPROVED: *[Signature]*  
DIRECTOR OF PUBLIC WORKS

Scale: NONE  
Date: 7-1-60  
Drawn By:

C-24

SACRAMENTO COUNTY  
DEPARTMENT OF PUBLIC WORKS  
HIGHWAY & BRIDGE DIVISION  
PIPE END SECTIONS

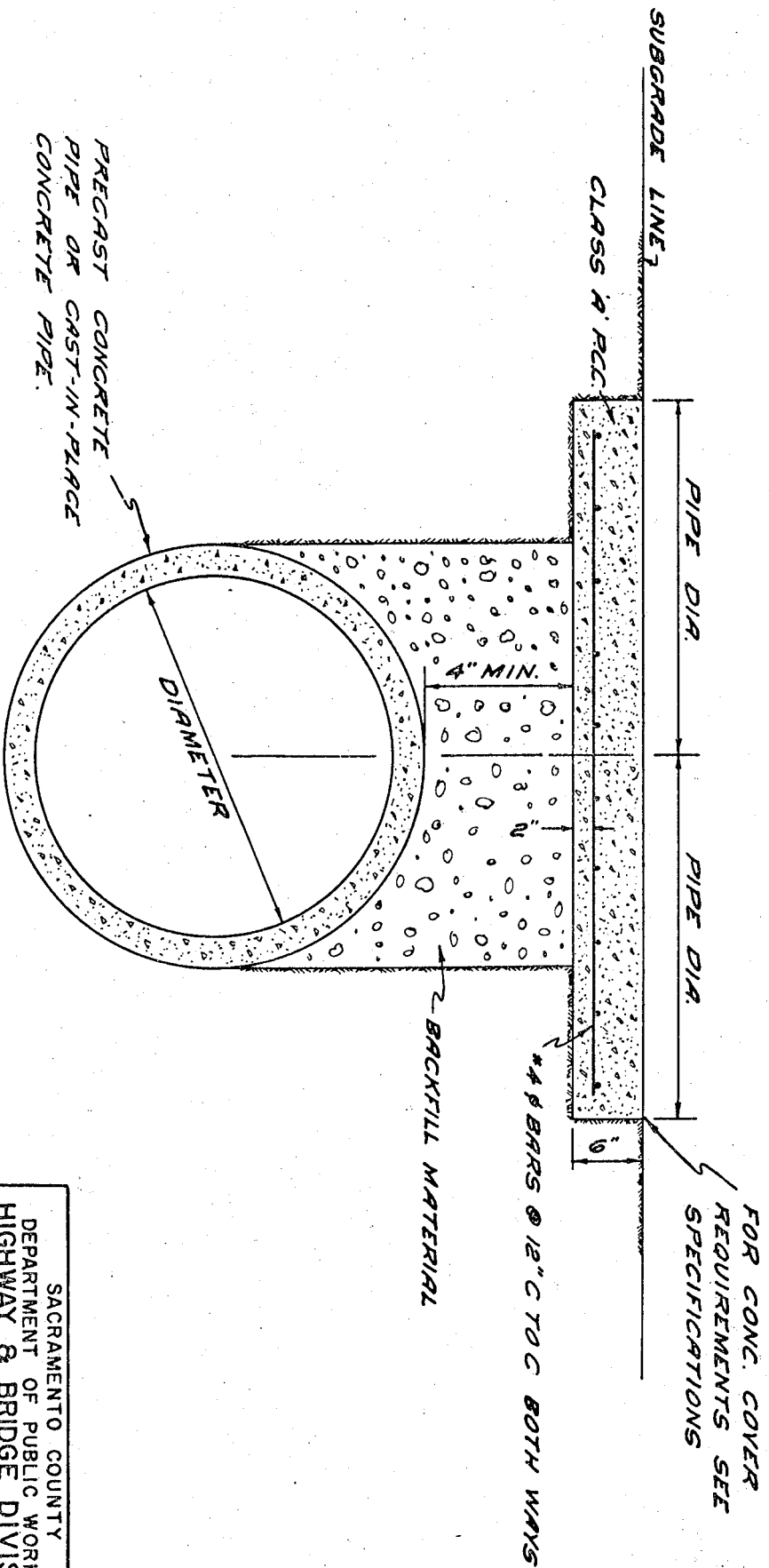

FOR CONC. COVER  
REQUIREMENTS SEE  
SPECIFICATIONS

CLASS A R.C.

SUBGRADE LINE

PIPE DIA.

PIPE DIA.

#4 BARS @ 12" C TO C BOTH WAYS

BACKFILL MATERIAL

4" MIN.

PRECAST CONCRETE  
PIPE OR CAST-IN-PLACE  
CONCRETE PIPE.

DIAMETER

CONCRETE PIPE COVER

SACRAMENTO COUNTY  
DEPARTMENT OF PUBLIC WORKS  
HIGHWAY & BRIDGE DIVISION

Scale: NONE  
Date: 1-1-60  
Drawn By: JCS

C-25

APPROVED: *A. S. Keenan*  
DIRECTOR OF PUBLIC WORKS

REDUCED

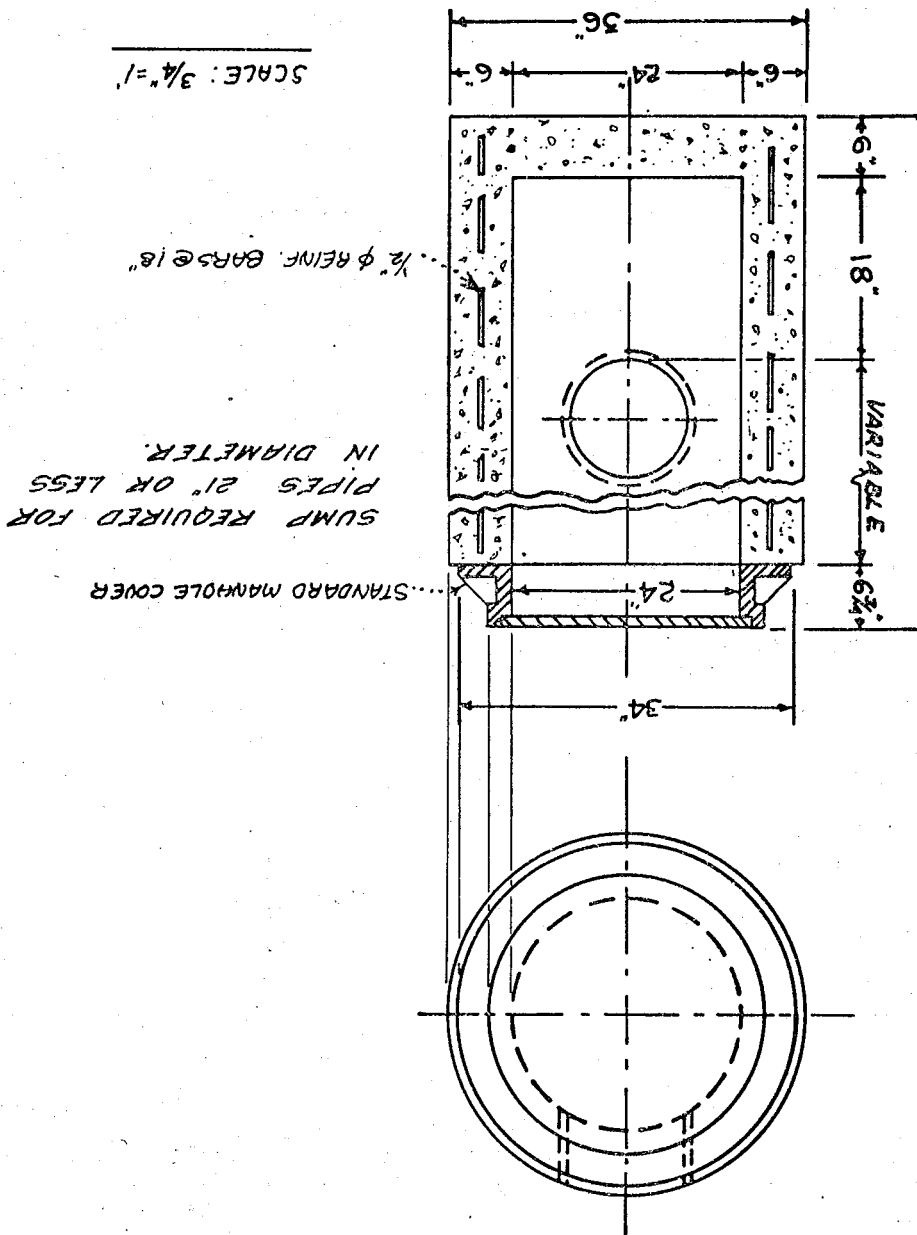

SCALE: 3/4"=1'

STANDARD MANHOLE COVER  
 SUMP REQUIRED FOR  
 PIPES 21" OR LESS  
 IN DIAMETER.  
 1/2" φ REINF. BARS @ 18"

USED WHERE TOP OF  
 PIPE IS LESS THAN  
 30" BELOW SURFACE.

SACRAMENTO COUNTY  
 DEPARTMENT OF PUBLIC WORKS  
 HIGHWAY & BRIDGE DIVISION

SPECIAL MANHOLE

Scale: NONE  
 Date: 6-61  
 Drawn By:

APPROVED: *A. P. Kiefer*  
 DIRECTOR OF PUBLIC WORKS

C-26

REDUCED

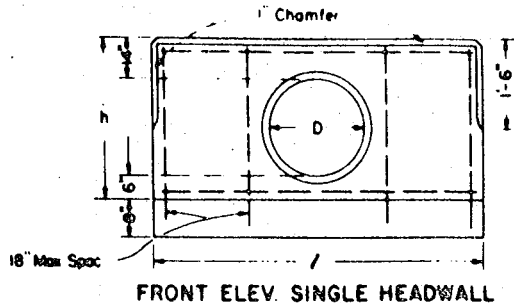

FRONT ELEV. SINGLE HEADWALL

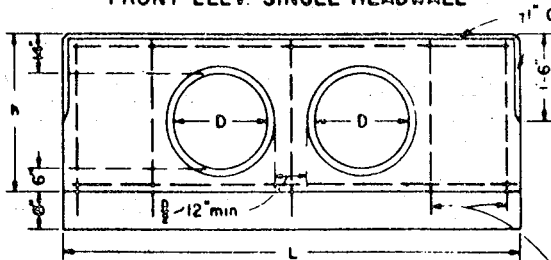

FRONT ELEV. DOUBLE HEADWALL

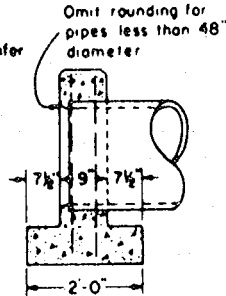

SECTION, SINGLE & DOUBLE HEADWALLS

D in.	h ft.-in.	Single			Double				
		L ft.-in.	Vert bars	Steel lbs	Conc C.Y.	L ft.-in.	Vert bars	Steel lbs	Conc. C.Y.
12	2-8	5-0	8	28	0.60	7-0	10	38	0.82
15	2-11	6-0	12	41	0.75	8-6	14	52	1.04
18	3-2	7-0	12	46	0.91	9-8	14	57	1.21
21	3-5	7-6	12	49	1.02	10-6	14	62	1.38
24	3-8	8-0	12	54	1.20	11-6	14	67	1.57
27	3-11	9-6	18	70	1.38	13-0	18	85	1.84
30	4-2	10-0	16	74	1.52	14-0	18	91	2.04
33	4-5	11-0	16	79	1.73	15-0	18	96	2.25
36	4-8	12-0	16	85	1.95	16-6	18	103	2.56
39	4-11	12-6	18	89	2.09	17-6	20	116	2.79
42	5-2	13-6	18	94	2.34	18-6	20	122	3.03
45	5-5	14-6	20	115	2.60	20-0	26	153	3.38
48	5-8	15-0	20	119	2.75	21-0	26	160	3.64
51	5-11	16-0	20	125	3.03	22-6	26	168	4.02
54	6-2	17-0	20	131	3.31	23-6	26	175	4.30

Use headwall tables for concrete pipe and for C.M.P.  
 No deduction made in quantities for variations in thickness of pipe walls.  
 All reinforcing steel #4 bars.

STRAIGHT HEADWALLS

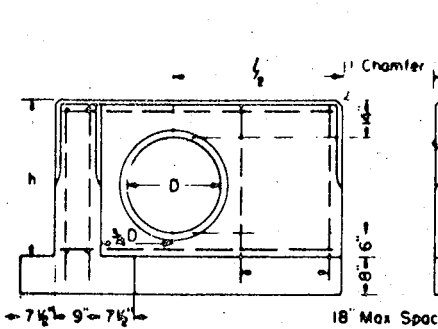

FRONT ELEV. "L" HEADWALL

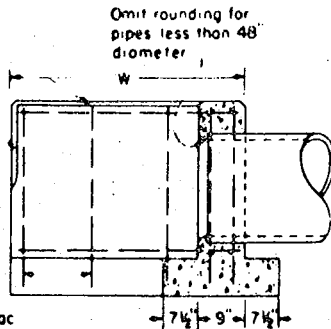

SECTION "L" HEADWALL

D in.	h ft.-in.	L ft.-in.	Length of W					Conc C.Y.
			2'-0" to 3'-4"	3'-5" to 4'-10"	4'-11" to 6'-4"	6'-5" to 7'-10"	7'-11" to 9'-4"	
			Number of Vertical Bars					
			6	8	10	12	14	
			Steel lbs					
12	2-8	2-6	28.3W	32.3W				0.58.0.12W
15	2-11	3-0	36.3W	41.3W				0.68.0.13W
18	3-2	3-6	40.3W	45.3W				0.59.0.14W
21	3-5	3-9	43.3W	48.3W				0.66.0.14W
24	3-8	4-3	47.3W	52.3W	59.3W			0.78.0.15W
27	3-11	4-9	57.3W	62.3W	68.3W			0.91.0.16W
30	4-2	5-0	60.3W	66.3W	73.3W	78.3W		1.00.0.17W
33	4-5	5-6	64.3W	71.3W	77.3W	83.3W		1.13.0.17W
36	4-8	6-0	68.3W	75.3W	82.3W	88.3W	95.3W	1.28.0.18W
39	4-11	6-3		79.3W	86.3W	93.3W	100.3W	1.39.0.19W
42	5-2	6-9		83.3W	91.3W	98.3W	106.3W	1.54.0.19W
45	5-5	7-3			103.3W	111.3W	119.3W	1.71.0.20W
48	5-8	7-6			108.3W	116.3W	124.3W	1.82.0.21W
51	5-11	8-0				121.3W	130.3W	2.00.0.21W
54	6-2	8-6				127.3W	136.3W	2.18.0.22W

"L" HEADWALLS

PIPE CULVERT HEADWALLS

SACRAMENTO COUNTY  
 DEPARTMENT OF PUBLIC WORKS  
 HIGHWAY & BRIDGE DIVISION

PIPE CULVERT  
 HEADWALL

APPROVED: *a p Kiefer*  
 DIRECTOR OF PUBLIC WORKS

Scale: NONE  
 Date: 6/61  
 Drawn By: STATE

C-27

FOR STORM DRAIN M.H. USE "D"  
 FOR SANITARY SEWER M.H. USE "S"

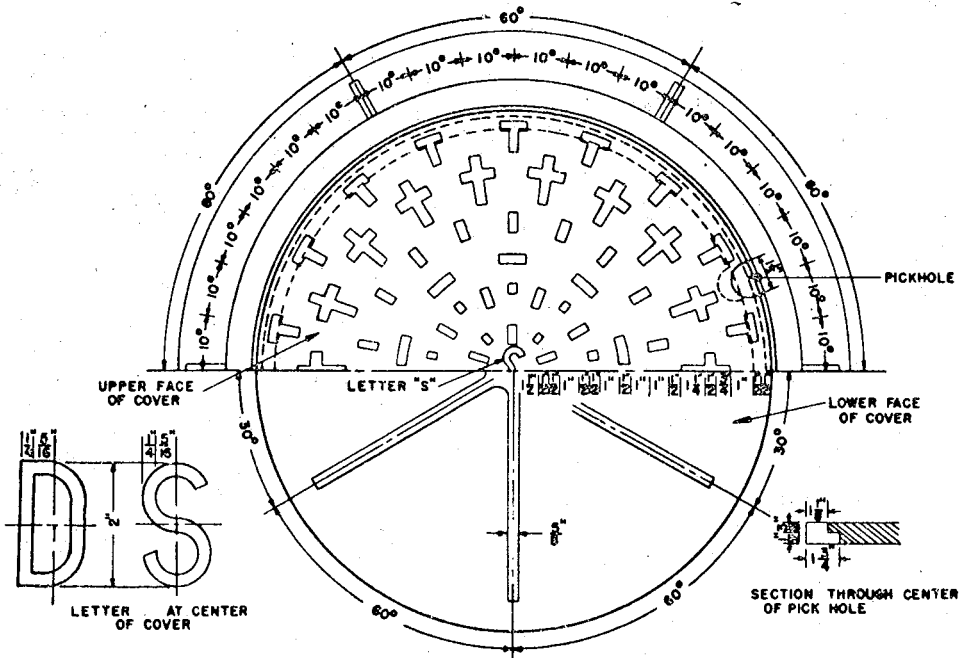

HALF PLAN OF MANHOLE FRAME AND COVER

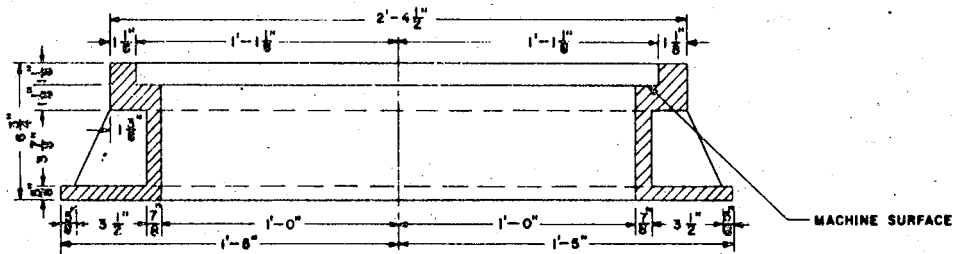

SECTION ON C THROUGH FRAME

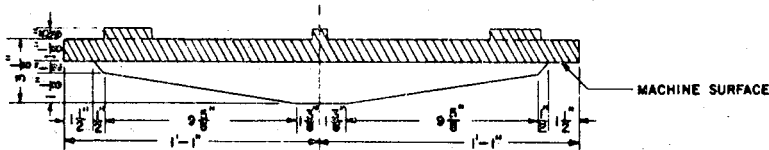

SECTION ON C THROUGH COVER

FRAME WT. Approx. 211 LBS.  
 COVER WT. Approx. 174 LBS.

APPROVED:

*A. E. ...*  
 DIRECTOR OF PUBLIC WORKS

SACRAMENTO COUNTY DEPARTMENT OF PUBLIC WORKS HIGHWAY & BRIDGE DIVISION	STANDARD 24"
	MANHOLE FRAME AND COVER
NO SCALE DATE: 1-19-60 DRAWN BY: J.F.O.B.	C-28

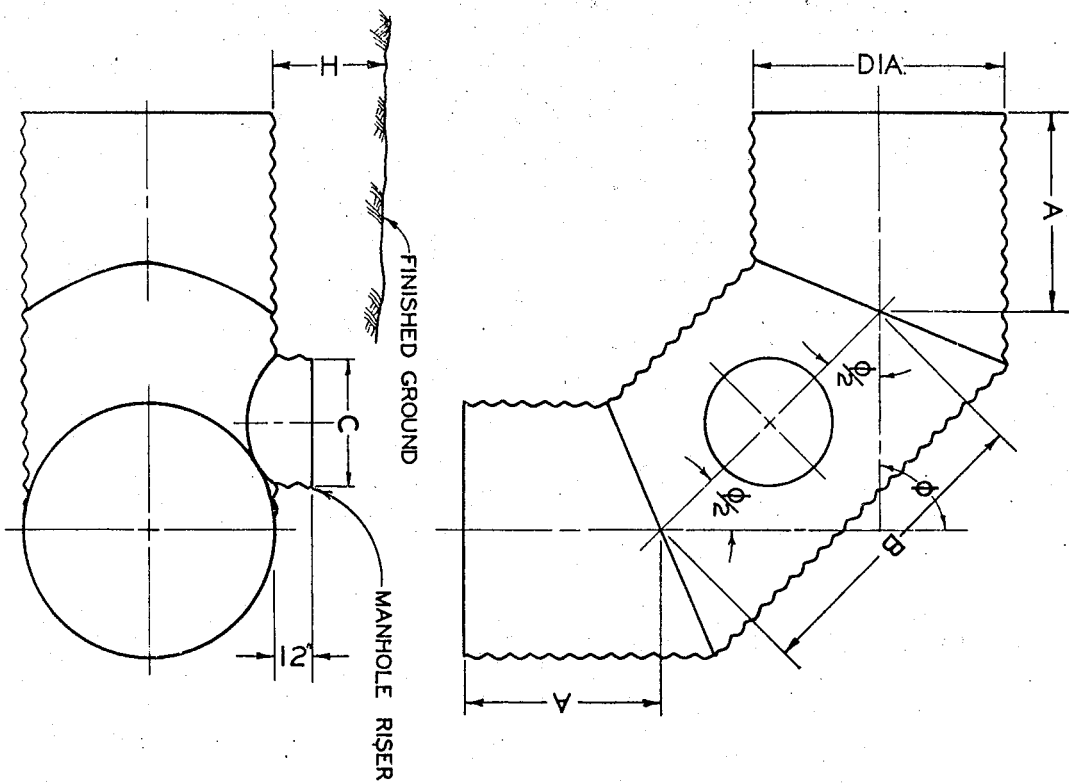

DIA. (IN)	C	H		
		H=1' TO 3'	H=3' TO 6'	H=6'+
42	24	24*	30*	36*
48	24	48*	60	60
54	24	48	60	60
60	24	60	60	60
66	36	60	66	72
72	36	60	66	72
78	36	60	66	72
84	36	60	66	72

- NOTES: 1. PIPE STRENGTH REQUIREMENTS TO BE DETERMINED FROM CHARTS C-5 AND C-5B.
- \*2. LENGTHS SHOWN ARE MINIMUM LENGTHS.
3. BACKFILL SHALL CONFORM TO COUNTY SPEC. DS-01.
4. IF THE MANHOLE IS NOT REQUIRED, THE DIMENSION 'A' SHALL APPLY FOR ALL THREE SECTIONS.

APPROVED: *[Signature]*  
 DIRECTOR OF PUBLIC WORKS

SACRAMENTO COUNTY DEPARTMENT OF PUBLIC WORKS HIGHWAY & BRIDGE DIVISION	
CORRUGATED METAL PIPE ELBOW	
SCALE: NONE DATE: 3-7-66 DRAWN BY: GEB	C-29

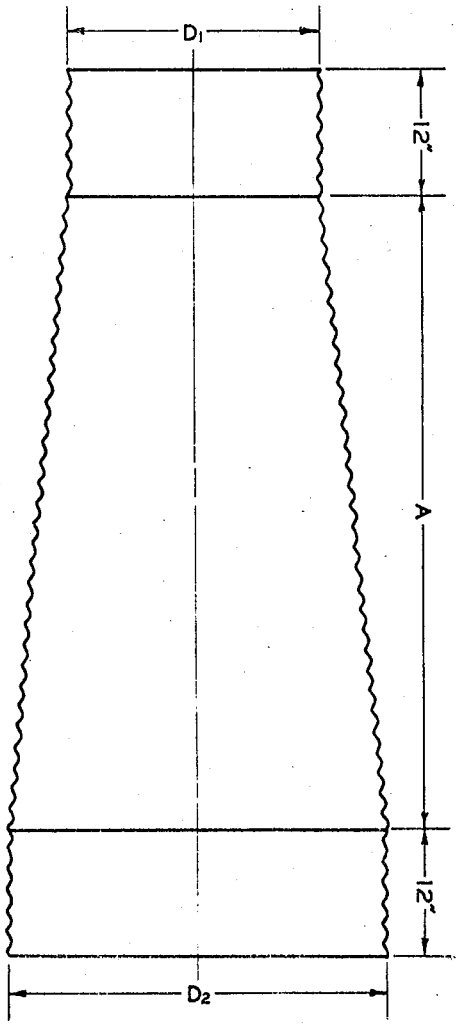

CONCENTRIC ENLARGER

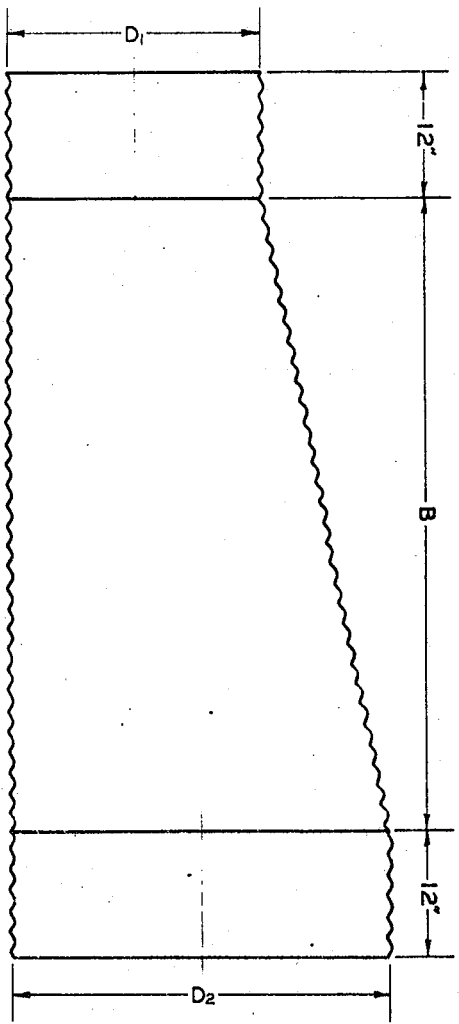

ECCENTRIC ENLARGER

D <sub>2</sub> - D <sub>1</sub>	A*	B*
3"	12"	12"
6"	24"	24"
9"	24"	30"
12"	24"	36"
15"	27"	42"
18"	36"	48"
21"	42"	54"
24"	48"	60"
27"	54"	66"
30"	60"	72"

**NOTES:**

1. PIPE STRENGTH REQUIREMENTS TO BE DETERMINED FROM CHARTS C-5 & C-5B
- \* 2. LENGTHS SHOWN ARE MINIMUM LENGTHS.
3. BACKFILL SHALL CONFORM TO PARAGRAPH D5-01 OF THE COUNTY SPECIFICATIONS.
4. MANUFACTURERS STANDARD ENLARGERS SHALL BE USED WHEN POSSIBLE. ALTERNATE DESIGNS MAY BE SUBMITTED FOR APPROVAL.

APPROVED: *[Signature]*  
DIRECTOR OF PUBLIC WORKS

SACRAMENTO COUNTY DEPARTMENT OF PUBLIC WORKS HIGHWAY & BRIDGE DIVISION	
CORRUGATED METAL PIPE ENLARGER	
SCALE: NONE DATE: 3-7-66 DRAWN BY: C.E.B.	C - 30

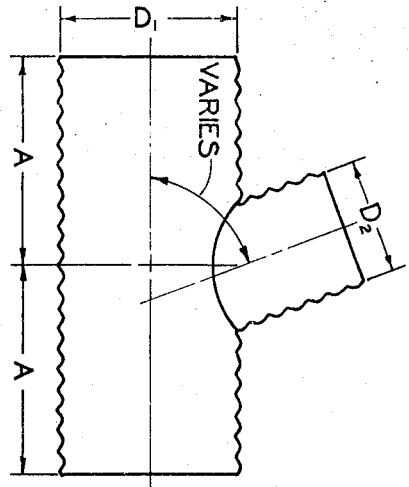

MANHOLE RISER

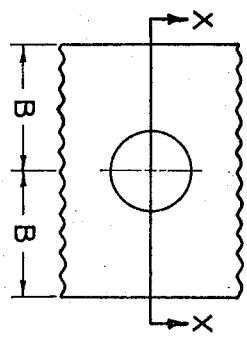

SECTION X - X

- NOTES:
1. LATERALS MAY BE FABRICATED TO MATCH TOPS, FLOWLINES, OR CENTERS OF MATING PIPES.
  2. LENGTHS SHOWN ARE MINIMUM LENGTHS.
  3. BACKFILL SHALL CONFORM TO COUNTY SPEC. D5-01.
  4. PIPE STRENGTH REQUIREMENTS TO BE DETERMINED FROM CHARTS C-5 AND C-5B.
  5. MINIMUM LENGTHS SHALL BE ADJUSTED AS REQUIRED TO PROVIDE FOR STANDARD BAND COUPLERS.

D <sub>1</sub>	A (IN)	C →		
		H=1' TO 3'	H=3' TO 6'	H=6'+
24" TO 36"	$D_2/2 + 14$	24"	30"	36"
42"	"	24	30	36
48"	"	"	"	"
60"	"	"	"	"
66"	"	30	33	"
72"	"	"	"	"
78"	"	"	"	"
84"	"	"	"	"

APPROVED: *[Signature]*  
DIRECTOR OF PUBLIC WORKS

SACRAMENTO COUNTY  
DEPARTMENT OF PUBLIC WORKS  
HIGHWAY & BRIDGE DIVISION  
CORR. METAL PIPE LATERAL  
WITH MANHOLE RISER

SCALE: NONE  
DATE: 3-9-66  
DRAWN BY: C.E.B.  
C-31



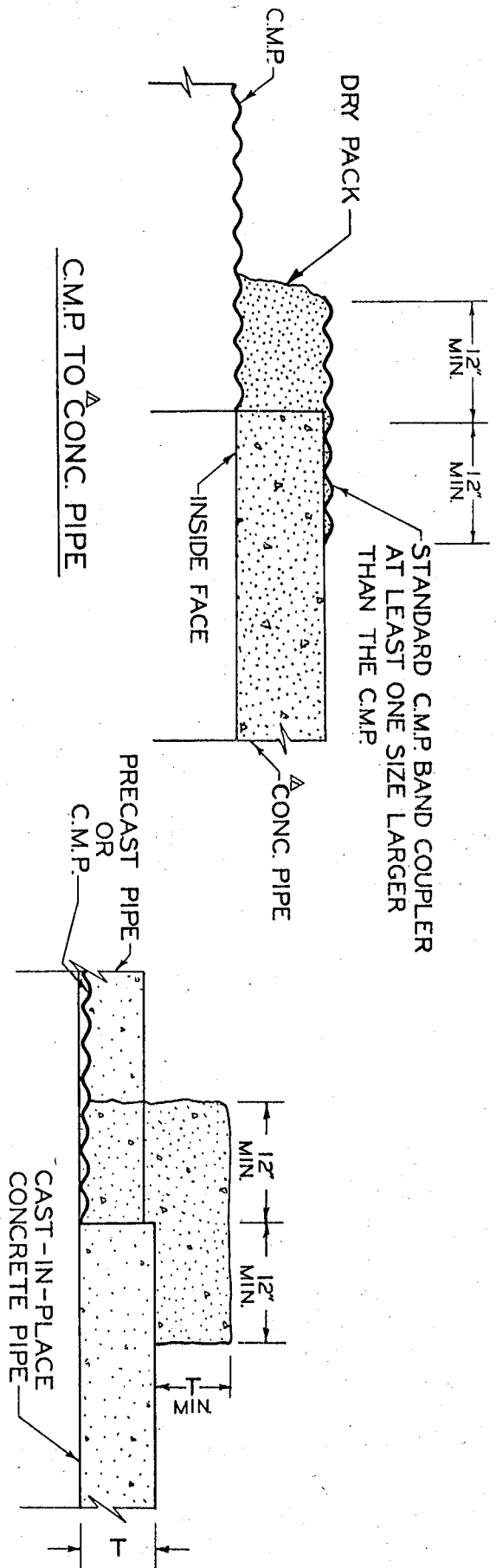

C.M.P. TO CONC. PIPE

CAST-IN-PLACE PIPE TO  
C.M.P. OR PRECAST PIPE

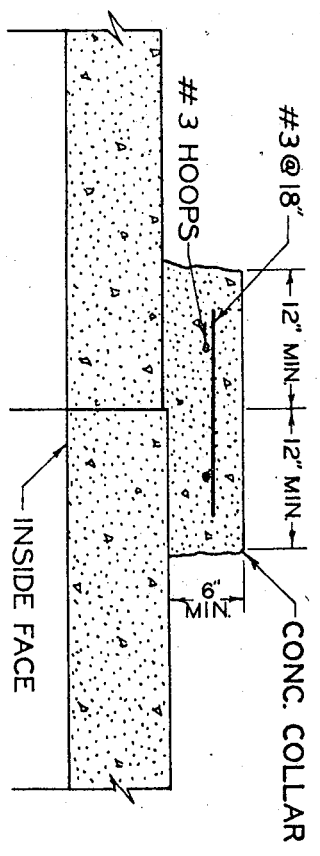

CONC. PIPE TO CONC. PIPE  
WITHOUT STANDARD JOINT

△ PRECAST CONCRETE PIPE

APPROVED: *[Signature]*  
 DIRECTOR OF PUBLIC WORKS

SACRAMENTO COUNTY  
 DEPARTMENT OF PUBLIC WORKS  
 HIGHWAY & BRIDGE DIVISION

SPECIAL COLLAR  
 CONNECTIONS

SCALE: NONE  
 DATE: 3-18-66  
 DRAWN BY: CEB

C-32

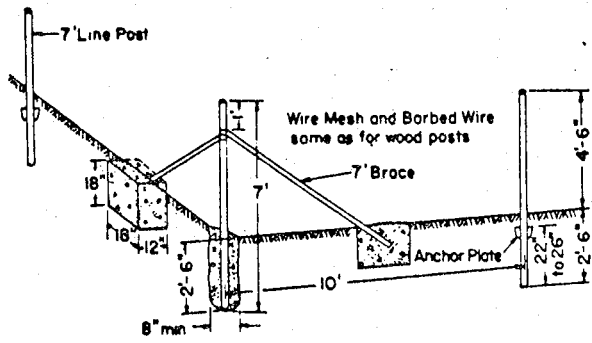

END, CORNER AND GATE POST ASSEMBLY

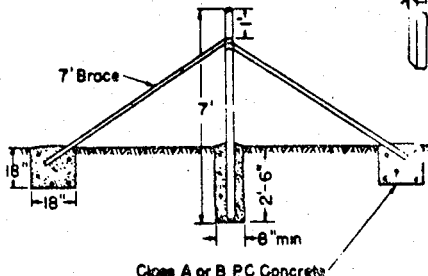

PULL POST ASSEMBLY  
at 500' maximum intervals

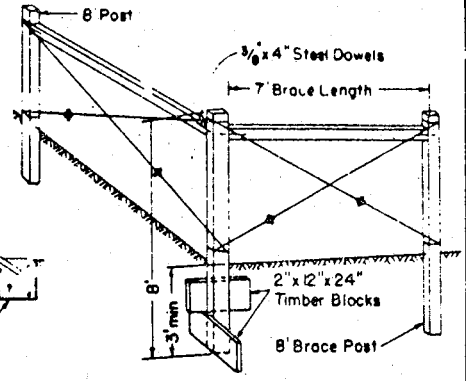

END, CORNER AND GATE POST ASSEMBLY

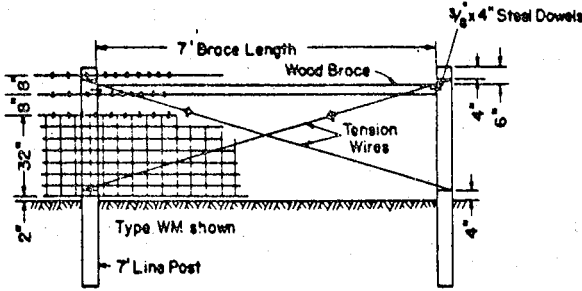

PULL POST ASSEMBLY  
at 1000' maximum intervals  
(for both BW and WM)

METAL POST INSTALLATION

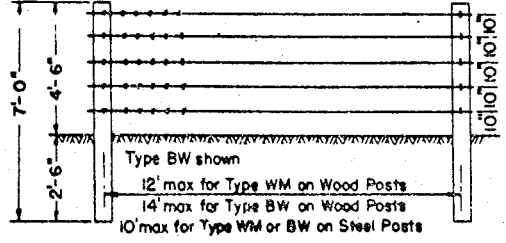

LINE POSTS  
WOOD POST INSTALLATION

Type BW = 5 lines of barbed wire  
Type WM = Wire mesh and 3 lines of barbed wire

PROPERTY FENCE

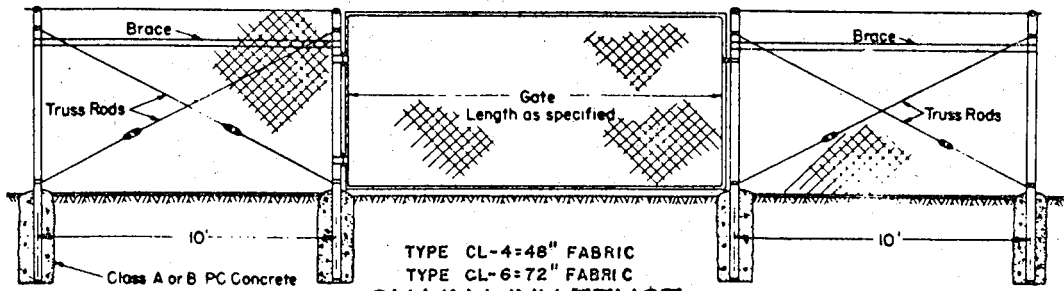
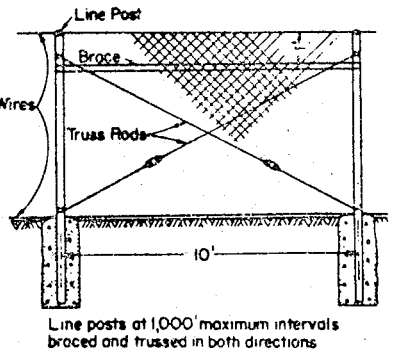
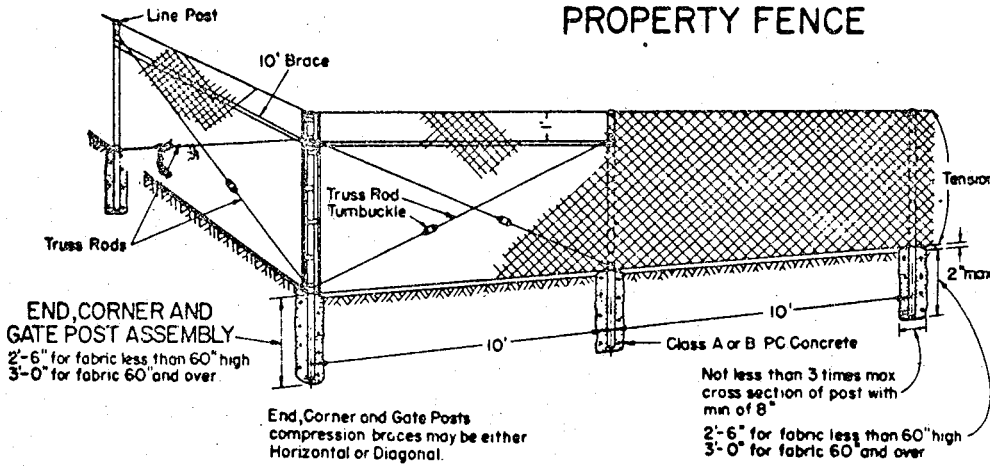

CHAIN LINK FENCE  
FREEWAY OR PROPERTY

REVISED 9-65

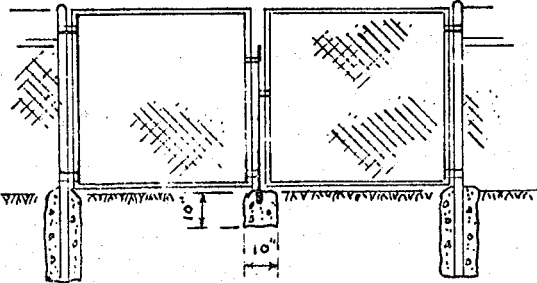

DOUBLE GATE

SACRAMENTO COUNTY  
DEPARTMENT OF PUBLIC WORKS  
HIGHWAY & BRIDGE DIVISION

STANDARD FENCE DETAILS

APPROVED

*a. p. Kiefer*  
DIRECTOR OF PUBLIC WORKS

Scale NONE  
Date: APRIL 1, 1965  
Drawn By

D-1

Std. W-21-R Reflector

Brace

10'-0"

9'-0"

2" x 18" x 10'-0"

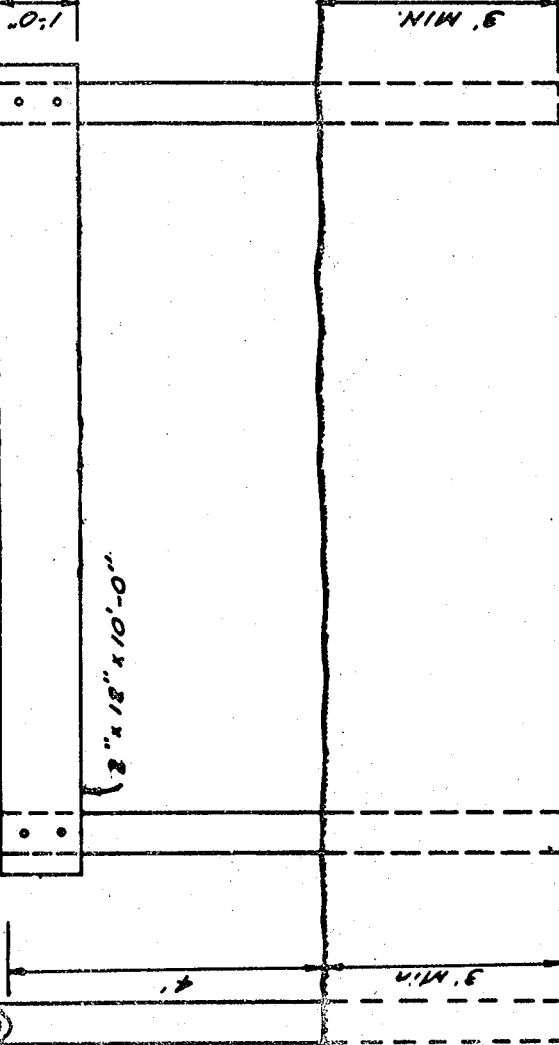

1/2" CARRIAGE BOLTS WITH CUT WASHERS & NUTS

6" x 6" x 7'-0" MIN.

SUBDIVISION LINE

END OF SURFACING 1 1/2"

2" x 6" REDWOOD HEADER

CENTER POST TO BE EXTENDED 4 FEET ABOVE PAVEMENT AND A STANDARD W-21-R REFLECTOR INSTALLED ON POST.

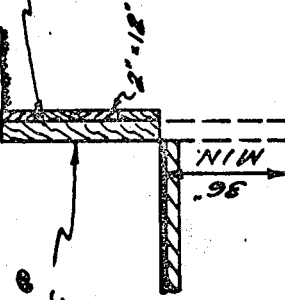

6" x 6" A.C.C.

TWO OR MORE BARRICADES TO BE ERECTED AT EACH STREET TERMINAL IN ACCORDANCE WITH THE SPECIFICATIONS - TO CLOSE STREET COMPLETELY BETWEEN R/W LINES. ONE STD. W-21-R SIGN WITH BRACE SHALL BE INSTALLED ON SEPARATE 4" x 4" REDWOOD S4S POST ADJACENT TO BARRICADES ON CENTERLINE OF STREET, AND AS DIRECTED BY THE ENGINEER.

All exposed surfaces to be painted with 2 coats of white paint conforming to section SI-3.02 of State Specifications.

STREET ENDING IN CUT WHERE SLOPE NOT OBTAINABLE.

SACRAMENTO COUNTY  
DEPARTMENT OF PUBLIC WORKS  
HIGHWAY & BRIDGE DIVISION

TIMBER BARRICADE

Scale: NONE  
Date: 1-1-60  
Drawn By: JFS

APPROVED: *R. L. Kiehl*  
DIRECTOR OF PUBLIC WORKS

D-2

REVISED 12-21-63 CR.

FOR TWO STREETS PLACE SECOND PAIR OF SIGNS ABOVE AND AT 90° TO SIGNS AS SHOWN

APPROVED: *A. E. ...*  
 DIRECTOR OF PUBLIC WORKS

Scale: NO SCALE  
 Date: 1-12-60  
 Drawn By: PS

SIGN DETAILS  
 FOR SINGLE STREET

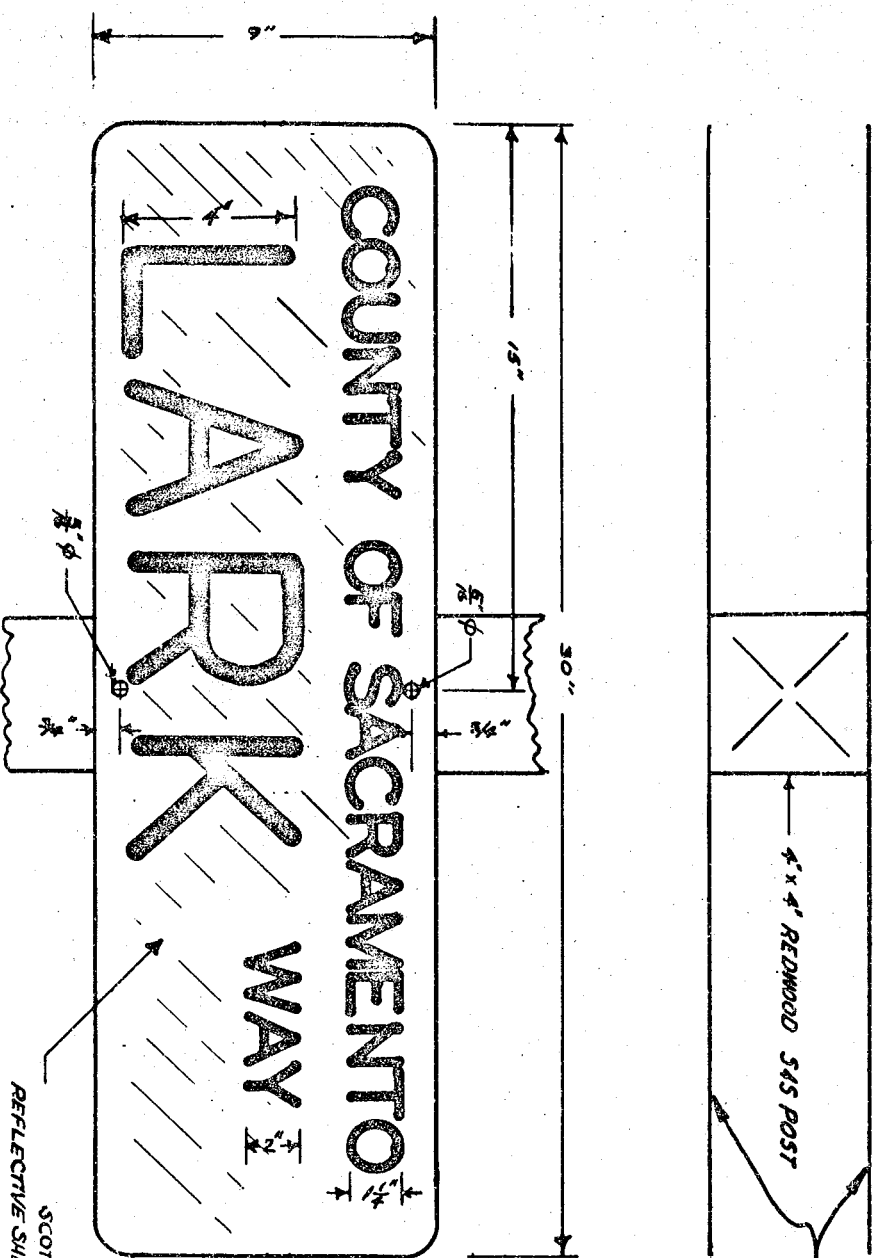

ALUMINUM SHEET ALLOY 6061-T6  
 0.125" GAUGE ROUNDED CORNERS  
 1-1/2" RADIUS

TWO SIGNS FOR EACH STREET

SACRAMENTO COUNTY  
 DEPARTMENT OF PUBLIC WORKS  
 HIGHWAY & BRIDGE DIVISION

STREET SIGN  
 FULLY REFLECTORIZED

D-3

SACRAMENTO COUNTY  
DEPARTMENT OF PUBLIC WORKS  
HIGHWAY & BRIDGE DIVISION

MAIL BOX PLACEMENT

Scale: *AS SHOWN*  
Date: 1-1-60  
Drawn By:

APPROVED: *A. E. Keller*  
DIRECTOR OF PUBLIC WORKS

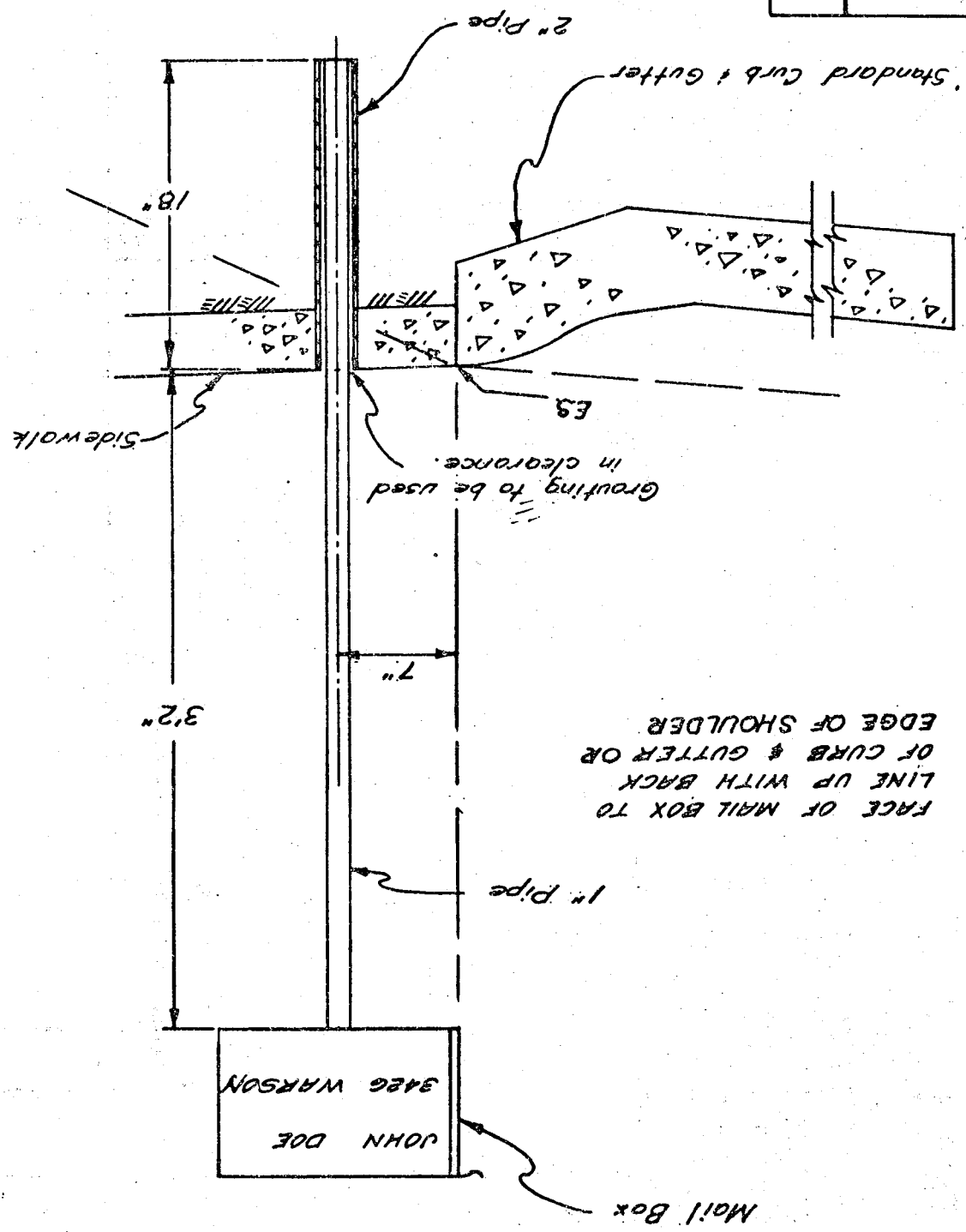

REVISED

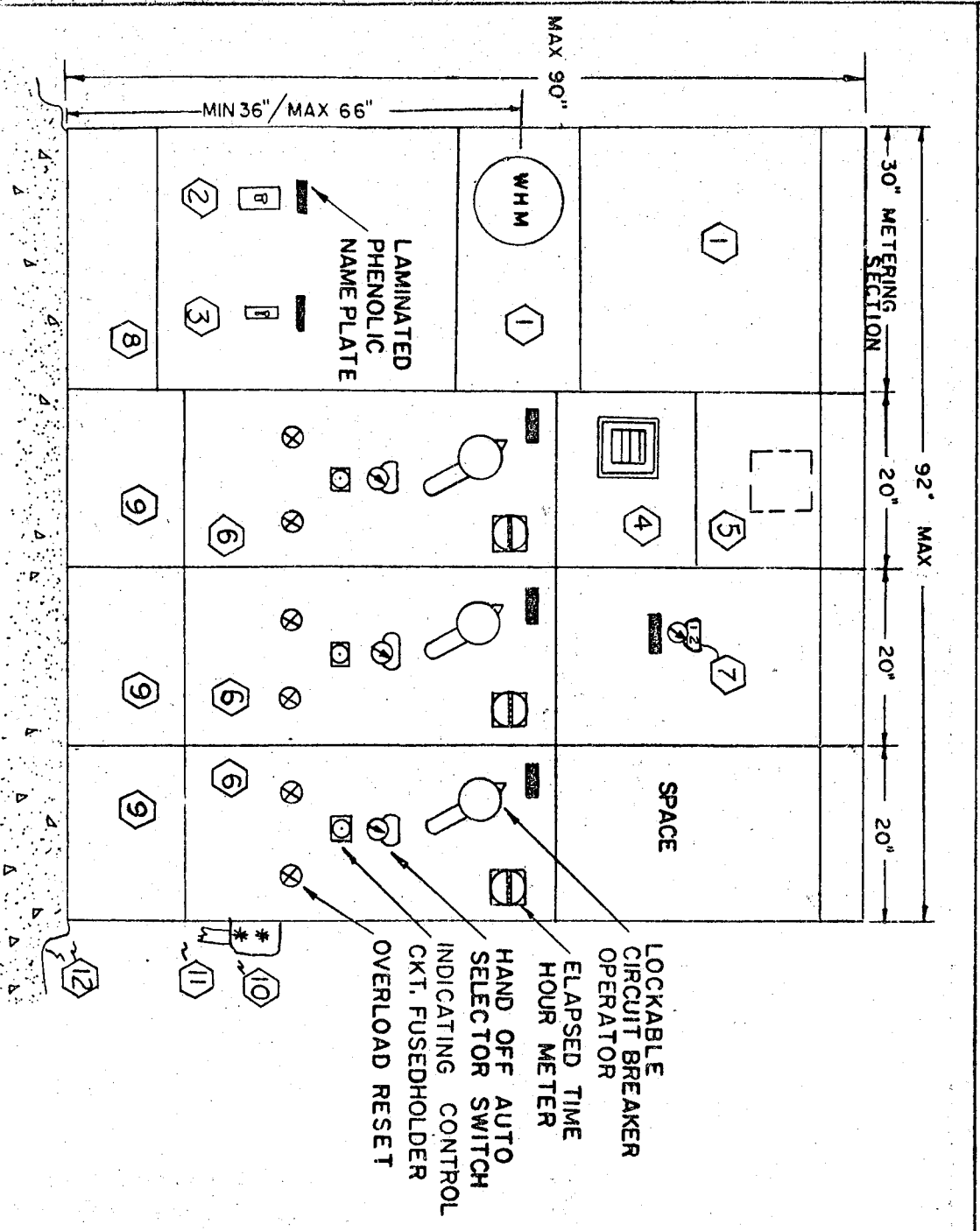

SCALE 3/4"=1'0"  
 MAX. DEPTH 20"

REDUCED

- LOCKABLE CIRCUIT BREAKER OPERATOR
- ELAPSED TIME HOUR METER
- HAND OFF AUTO SELECTOR SWITCH
- INDICATING CONTROL CKT. FUSEDHOLDER
- OVERLOAD RESET

480 Volt, 3 Phase, 3 Wire  
 3 Units - 60 to 100 H.P. each - use all sections except (7)  
 2 Units - 75 to 100 H.P. each - do not require shaded sections  
 ○ - refers to number on identification list

SACRAMENTO COUNTY	
DEPARTMENT OF PUBLICWORKS	
HIGHWAY & BRIDGE DIVISION	
PERMANENT INST'L'N	
INDOOR MOTOR	
CONTROL	CENTER
JANUARY '64	E-1

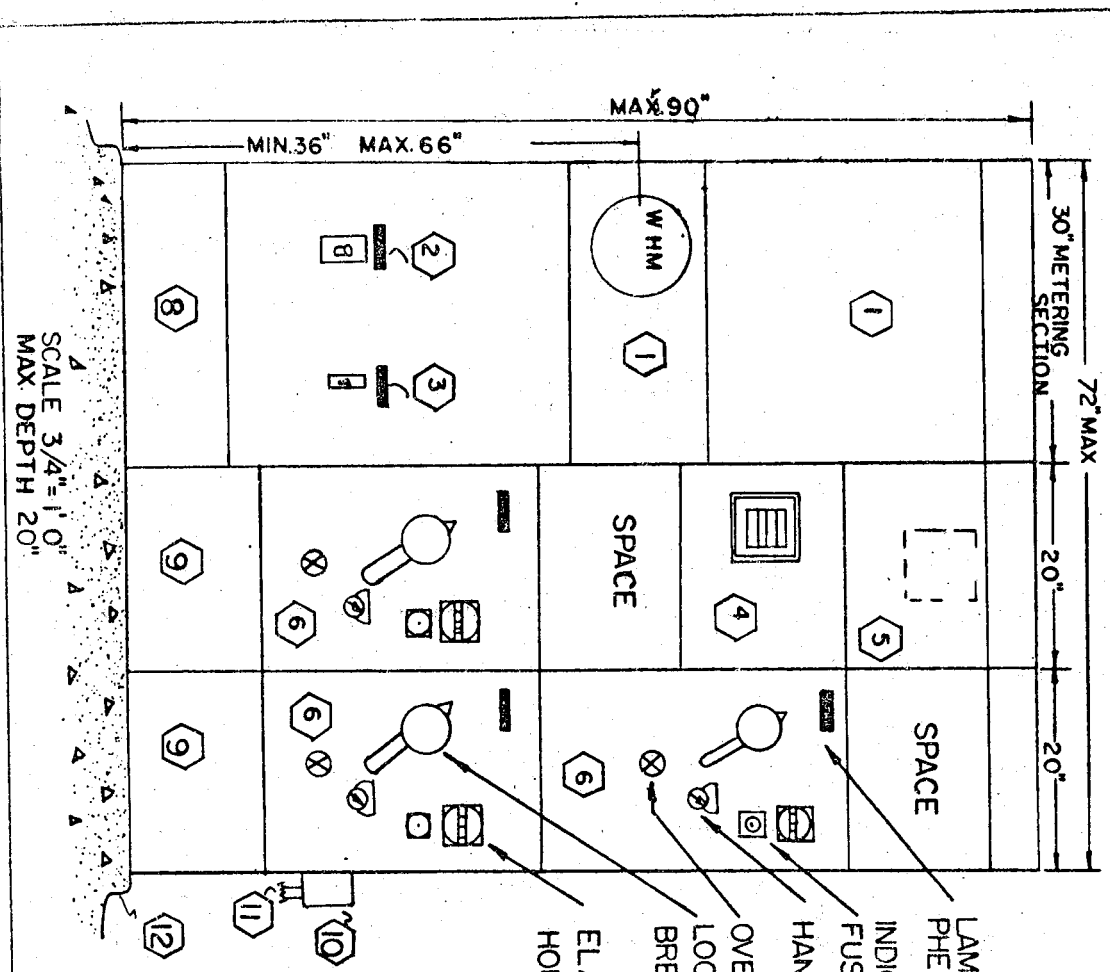

- 1 LAMINATED PHENOLIC NAMEPLATE
- 2 INDICATING CONT. CKT
- 3 FUSE HOLDER
- 4 HAND OFF AUTO SELECTOR SWITCH
- 5 OVERLOAD RESET
- 6 LOCKABLE CIRCUIT BREAKER OPERATOR
- 7 ELAPSED TIME HOUR METER
- 8 SPACE
- 9 SPACE
- 10 SPACE
- 11 SPACE
- 12 SPACE

SCALE 3/4" = 1' 0"  
MAX DEPTH 20"

REDUCED

480 VOLT, 3 PHASE, 3 WIRE

3 UNITS - 50 H. P. each

○ - refers to number on identification list, except that Item 6 is: circuit breaker, combination line starter with control XFMR, H. D. O. T. H-O-A selector switch, time-delay relay, control circuit indicating fuse holder, hour meter - wired per Drawing E-12 with space heater and thermostat.

SACRAMENTO COUNTY DEPARTMENT OF PUBLIC WORKS HIGHWAY & BRIDGE DIVISION	PERMANENT INST'L'N INDOOR MOTOR CONTROL CENTER
JANUARY '64	E-2

REDUCED

SCALE 3/4" = 1' 0"  
MAX DEPTH 20"

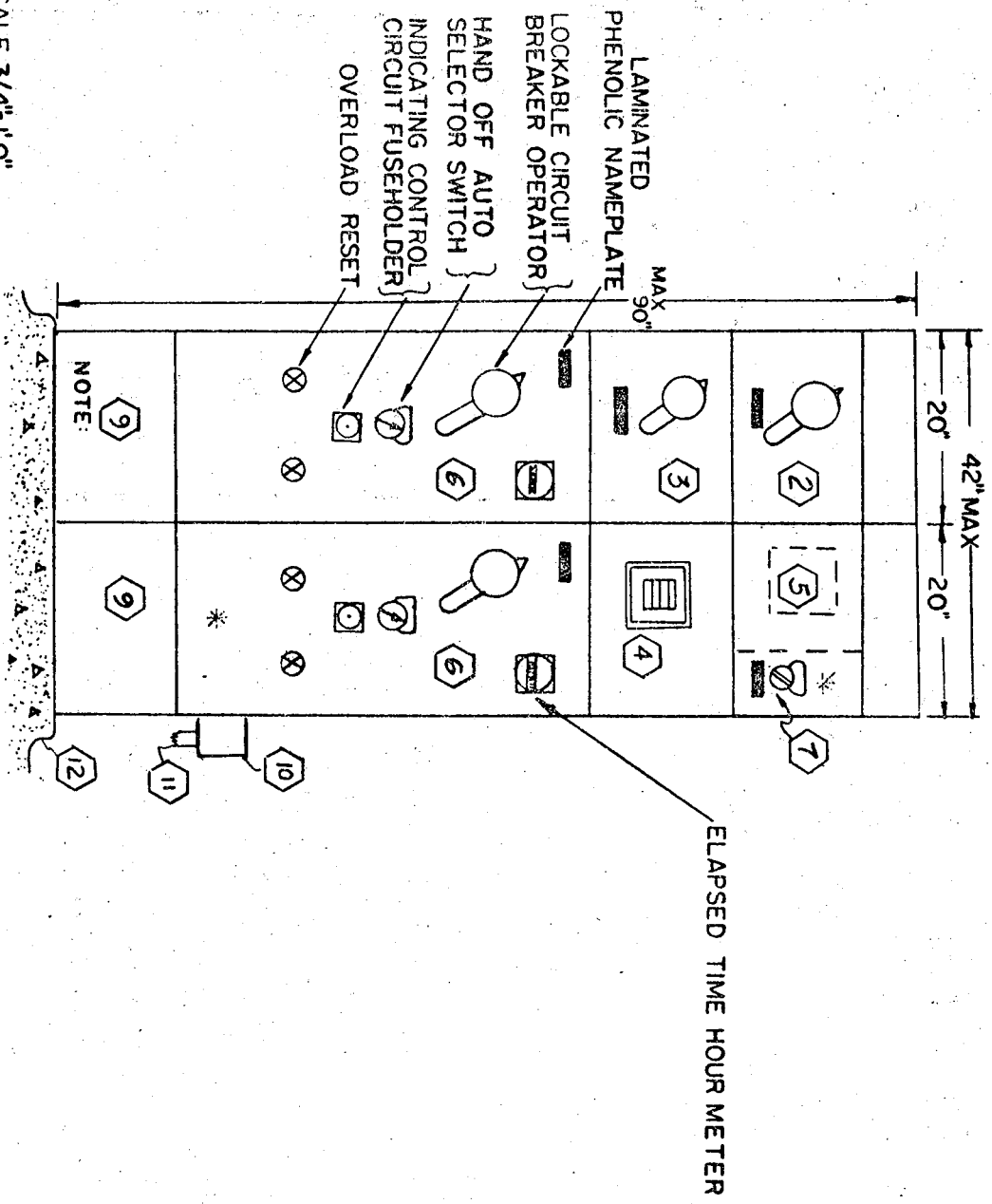

Note: Power metering to be located on service pole. Conduit from meter rises in this space - provide raceway.

480 VOLT, 3 PHASE, 3 WIRE  
2 UNITS - 60 H. P. each, require all sections shown  
1 UNIT - 60 H. P. does not require shaded sections  
○ - refers to number on identification list

SACRAMENTO COUNTY	
DEPARTMENT OF PUBLIC WORKS	
HIGHWAY & BRIDGE DIVISION	
PERMANENT INST'L'N	CONTROL CENTER
JANUARY '64	E-3



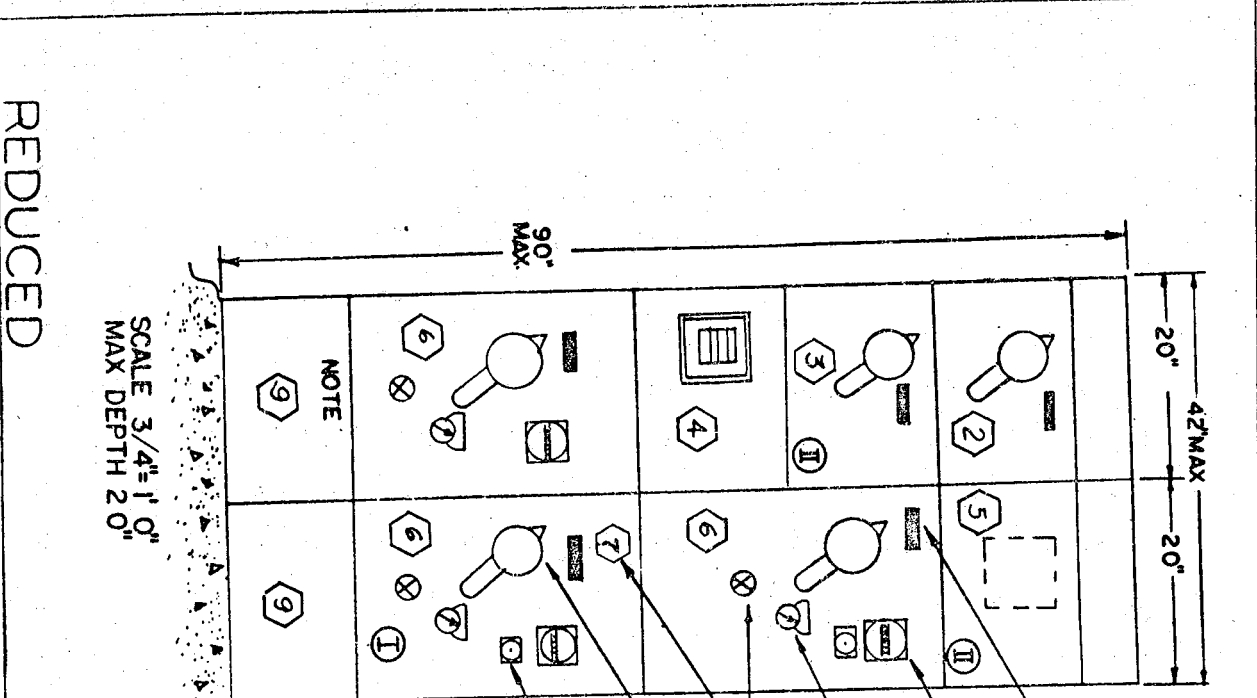

SCALE 3/4" = 1' 0"  
MAX DEPTH 20"

REDUCED

- LAMINATED PHENOLIC NAMEPLATE
- ELAPSED TIME HOUR METER
- HAND OFF AUTO SELECTOR SWITCH
- OVERLOAD RESET (REQUIRED FOR INSTALLATION)
- LOCKABLE CIRCUIT BREAKER OPERATOR
- CONTROL CIRCUIT INDICATING FUSE HOLDER
- NOTE

Note: Power meter to be located on service pole. Conduit from meter rises in this space - provide raceway.

- 480 VOLT, 3 PHASE, 3 WIRE
- 3 UNITS - 30 to 40 H. P. require all sections
- 2 UNITS - 30 to 50 H. P., delete Section 1
- 1 UNIT - 30 to 50 H. P. use 2, 3, 4, 5, 6, 10 arranged for 20 inch width
- 240 VOLT, 3 PHASE, 4 WIRE
- 3 UNITS - 20 to 25 H. P. delete Sections 1 and 10
- 2 UNITS - 20 to 25 H. P. delete Sections 1 and 10
- 6 - refers to number on identification list except that Item 6 is: circuit breaker, combination type starter with control XFMR, H. D. O. T., H-O-A selector switch, time delay relay, control circuit indicating fuseholder, hour meter wired per Drawing E-12 with space heater and thermostat.

SACRAMENTO COUNTY	
DEPARTMENT OF PUBLIC WORKS	
HIGHWAY & BRIDGE DIVISION	
PERMANENT INST'L IN	
INDOOR MOTOR	
CONTROL CENTER	
JANUARY '64	E 4

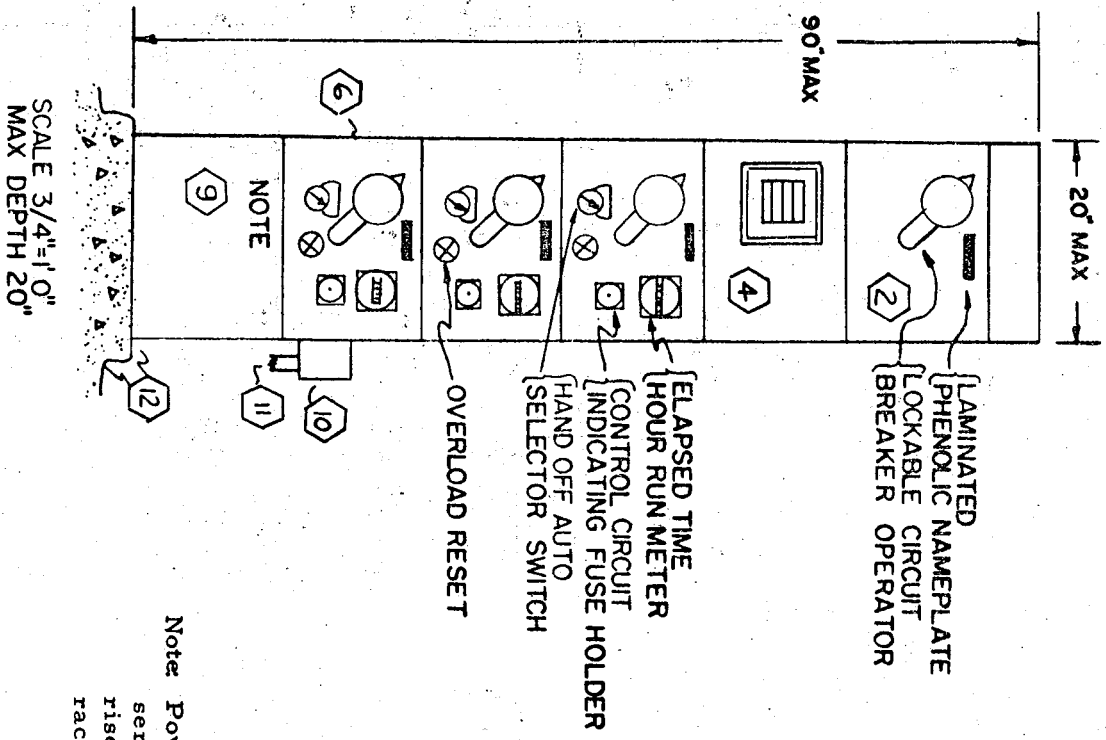

{ LAMINATED NAMEPLATE  
 { PHENOLIC CIRCUIT BREAKER OPERATOR

{ ELAPSED TIME  
 { HOUR RUN METER  
 { CONTROL FUSE HOLDER  
 { HAND OFF AUTO SELECTOR SWITCH

OVERLOAD RESET

NOTE

SCALE 3/4"=1'0"  
 MAX DEPTH 20"

Note: Power meter to be located on service pole. Conduit from meter rises in this space - provide raceway.

240 VOLTS, 3 PHASE, 4 WIRE

3 UNITS - 7-1/2 to 15 H.P. each

○ - refers to number on identification list, except that Item 6 is: circuit breaker, combination linestarter with control XFMR, H. D. O. T. H-O-A selector switch, time delay relay, control circuit with indicating fuseholder, hour meter - wired per Drawing E-12, with space heater and thermostat.

REDUCED

SACRAMENTO COUNTY	
DEPARTMENT OF PUBLIC WORKS	
HIGHWAY & BRIDGE DIVISION	
PERMANENT INST'L'N	
INDOOR MOTOR	
CONTROL CENTER	
JANUARY'64	E-5

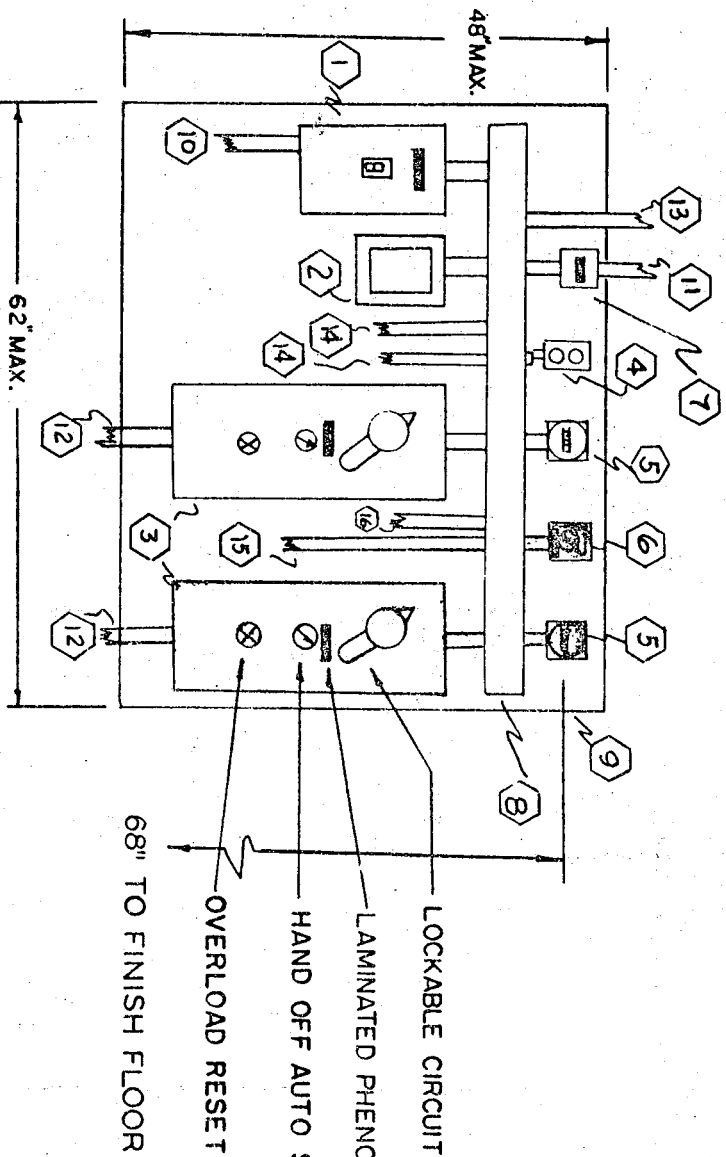

LOCKABLE CIRCUIT BREAKER OPERATOR  
 LAMINATED PHENOLIC NAMEPLATE  
 HAND OFF AUTO SELECTOR SWITCH  
 OVERLOAD RESET  
 68" TO FINISH FLOOR

240 VOLTS, 3 PHASE, 4 WIRE  
 1 UNIT - 7-1/2 to 25 H.P. delete shaded sections  
 2 UNITS - 7-1/2 to 15 H.P. require all sections  
 ○ - refers to number on identification list

SCALE: 3/4"=1'-0"

REDUCED

SACRAMENTO COUNTY DEPARTMENT OF PUBLIC WORKS HIGHWAY & BRIDGE DIVISION	
PERMANENT INST'L'N INDOOR COMPOSITE CONTROL ASSEMBLY	
JANUARY '64	E-6

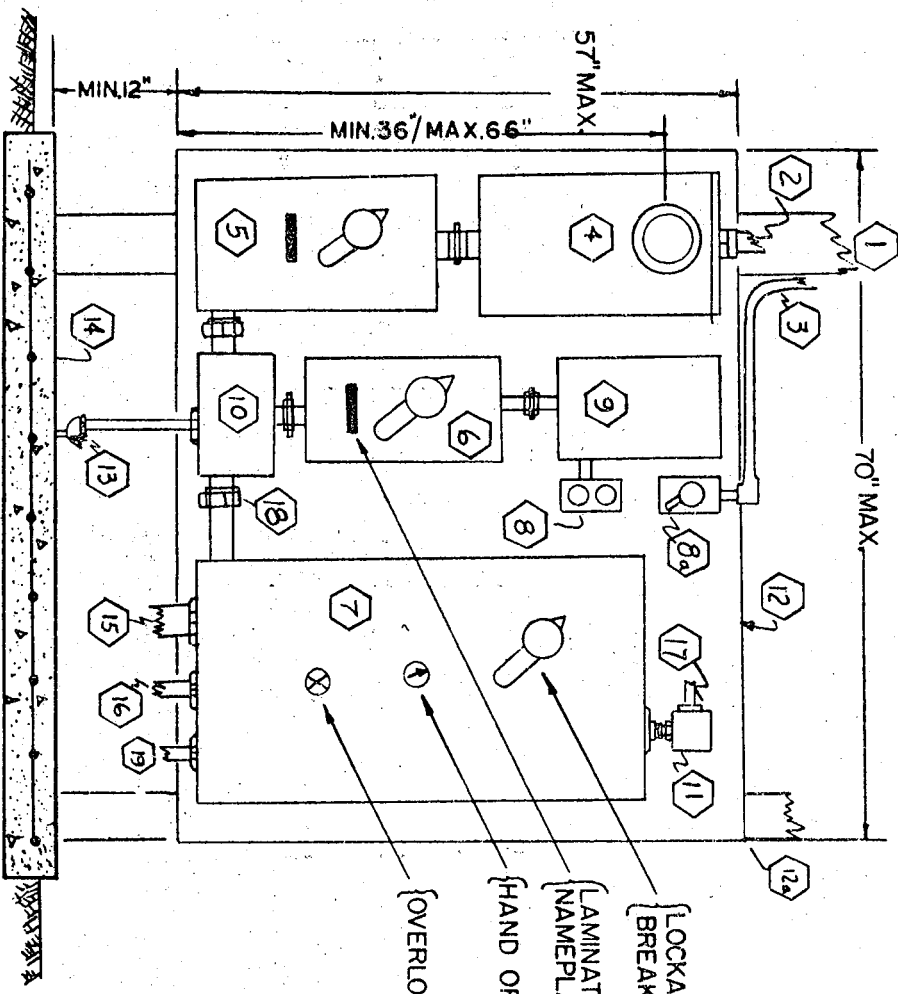

{ LOCKABLE CIRCUIT BREAKER OPERATOR  
 { LAMINATED PHENOLIC NAMEPLATE  
 { HAND OFF AUTO SELECTOR SWITCH  
 { OVERLOAD RESET

480 VOLTS, 3 PHASE, 3 WIRE  
 1 UNIT - 30 to 100 H.P.  
 ○ - refers to number on identification list

SCALE 3/4"=1'0"

100 HP SHOWN

REDUCED

SACRAMENTO COUNTY	
DEPARTMENT OF PUBLIC WORKS	
HIGHWAY 8 BRIDGE DIVISION	
TEMPORARY INST'L'N	
OUTDOOR COMPOSITE	
CONTROL ASSEMBLY	
JANUARY '64	E-7

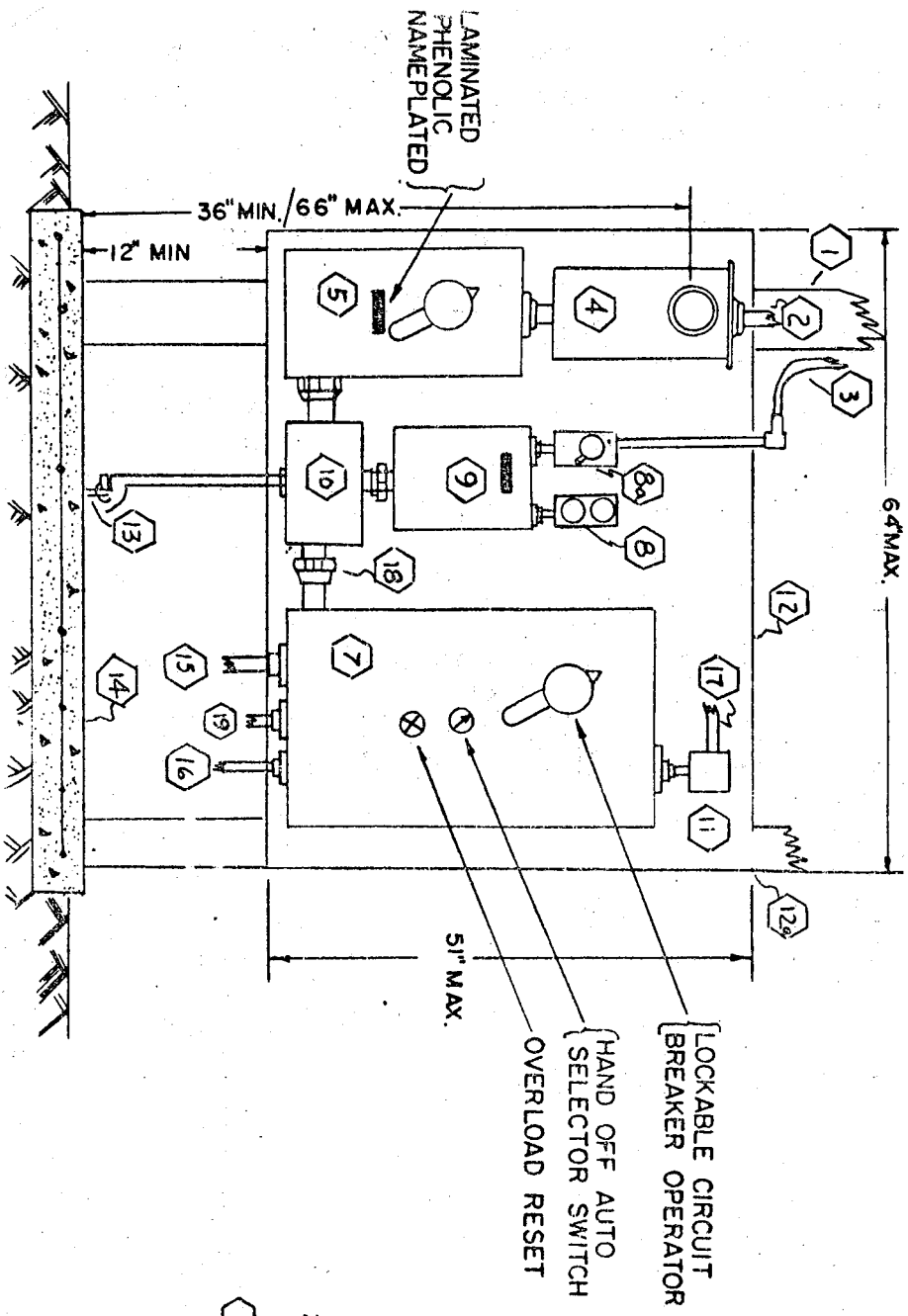

SCALE 3/4"=1' 0"

25 HP SHOWN  
REDUCED

240 VOLT, 3 PHASE, 4 WIRE  
1 UNIT - 7-1/2 to 25 H. P.  
○ - refers to number on identification list

SACRAMENTO COUNTY DEPARTMENT OF PUBLIC WORKS HIGHWAY 8 BRIDGE DIVISION	TEMPORARY INST'L'N OUTDOOR COMPOSITE CONTROL ASSEMBLY
JANUARY '64	E-8

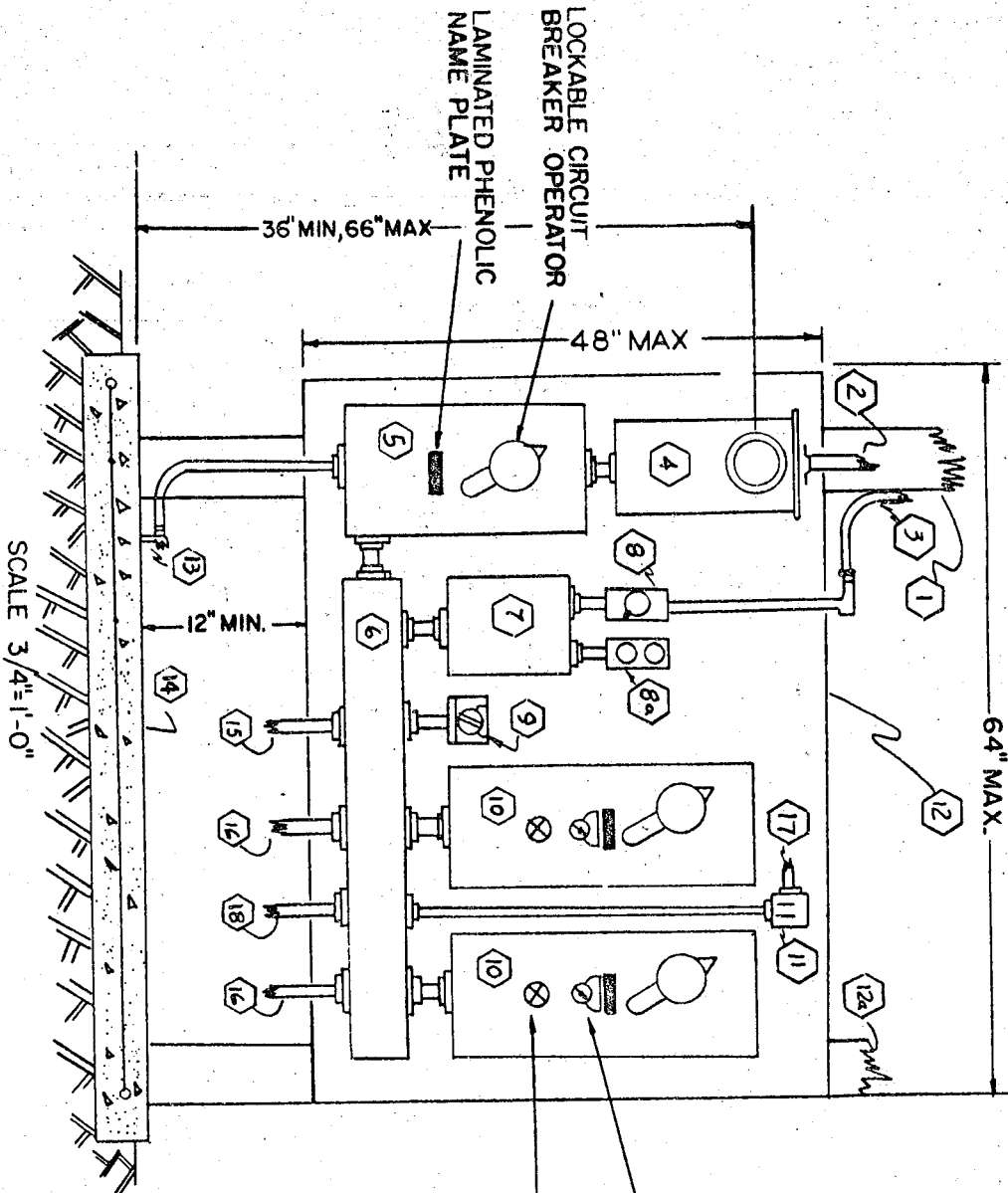

HAND OFF AUTO SELECTOR SWITCH  
OVERLOAD RESET

240 VOLTS, 3 PHASE, 4 WIRE  
2 UNITS - 7-1/2 to 15 H.P. Each  
- refers to number on identification list

REDUCED

SACRAMENTO COUNTY	
DEPARTMENT OF PUBLIC WORKS	
HIGHWAY 8 BRIDGE DIVISION	
TEMPORARY INST'L'N	
OUTDOOR COMPOSITE	
CONTROL ASSEMBLY	
JANUARY '64	E-9

REDUCED

SCALE 3/4" = 1' 0" PANEL MAX DEPTH 24" W/ EXTERIOR DOORS

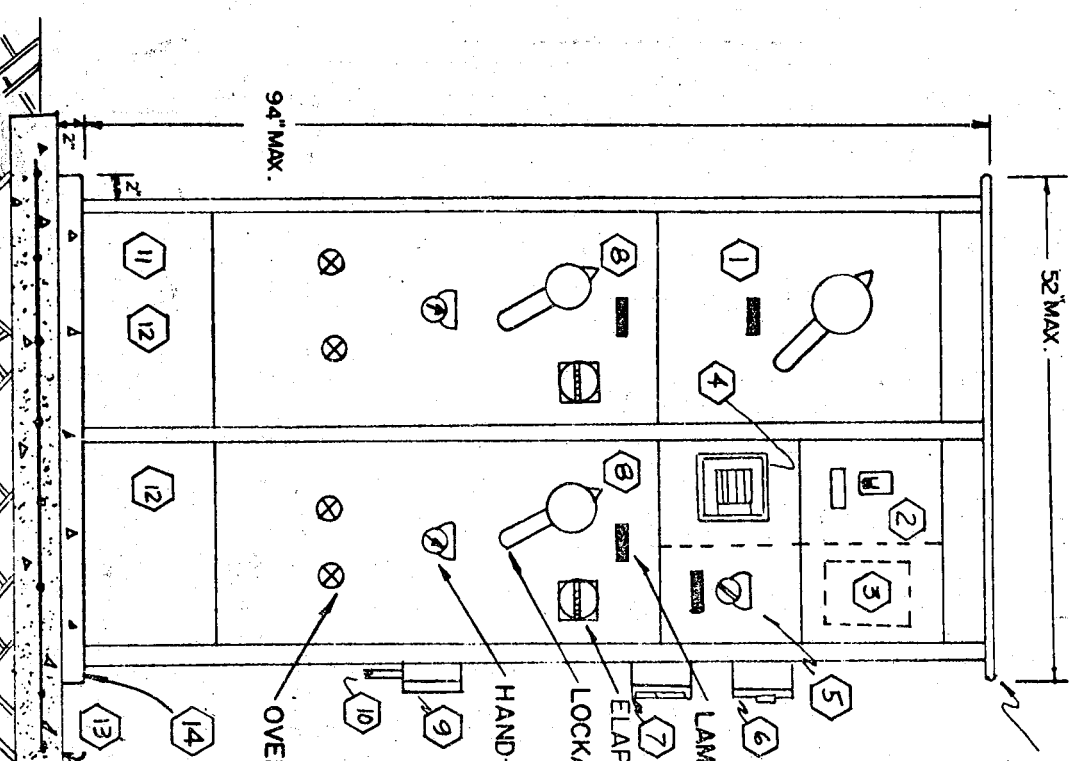

D RIP SHIELD ROOF  
 3" MIN OVERHANG SIDES &  
 BACK, 4" FRONT. SLOPE TO  
 DRAIN TO REAR

52" MAX.

94" MAX.

1

2

3

4

5

6

7

8

9

10

11

12

13

14

LAMINATED PHENOLIC NAMEPLATES

ELAPSED TIME HOURMETER

LOCKABLE CIRCUIT BREAKER OPERATOR

HAND-OFF-AUTO SELECTOR SWITCH

OVERLOAD RESET

Note: NEMA 3R construction shown. Exterior door removed. Non-walkin./step-in.

2 UNITS - 100 H. P. EACH SHOWN  
 Construction typical w/ modification for

- 480 VOLTS, 3 PHASE, 3 WIRE
- 2 UNITS - 30 to 100 H. P. each
- 3 UNITS - 30 to 50 H. P. each
- 240 VOLTS, 3 PHASE, 4 WIRE
- 2 UNITS - 20 to 25 H. P. each
- 3 UNITS - 7-1/2 to 25 H. P. each

○ - refers to number on identification list

SACRAMENTO COUNTY DEPARTMENT OF PUBLIC WORKS HIGHWAY & BRIDGE DIVISION	
TEMPORARY INST'L'N OUTDOOR MOTOR CONTROL CENTER	
JANUARY '64	E-10

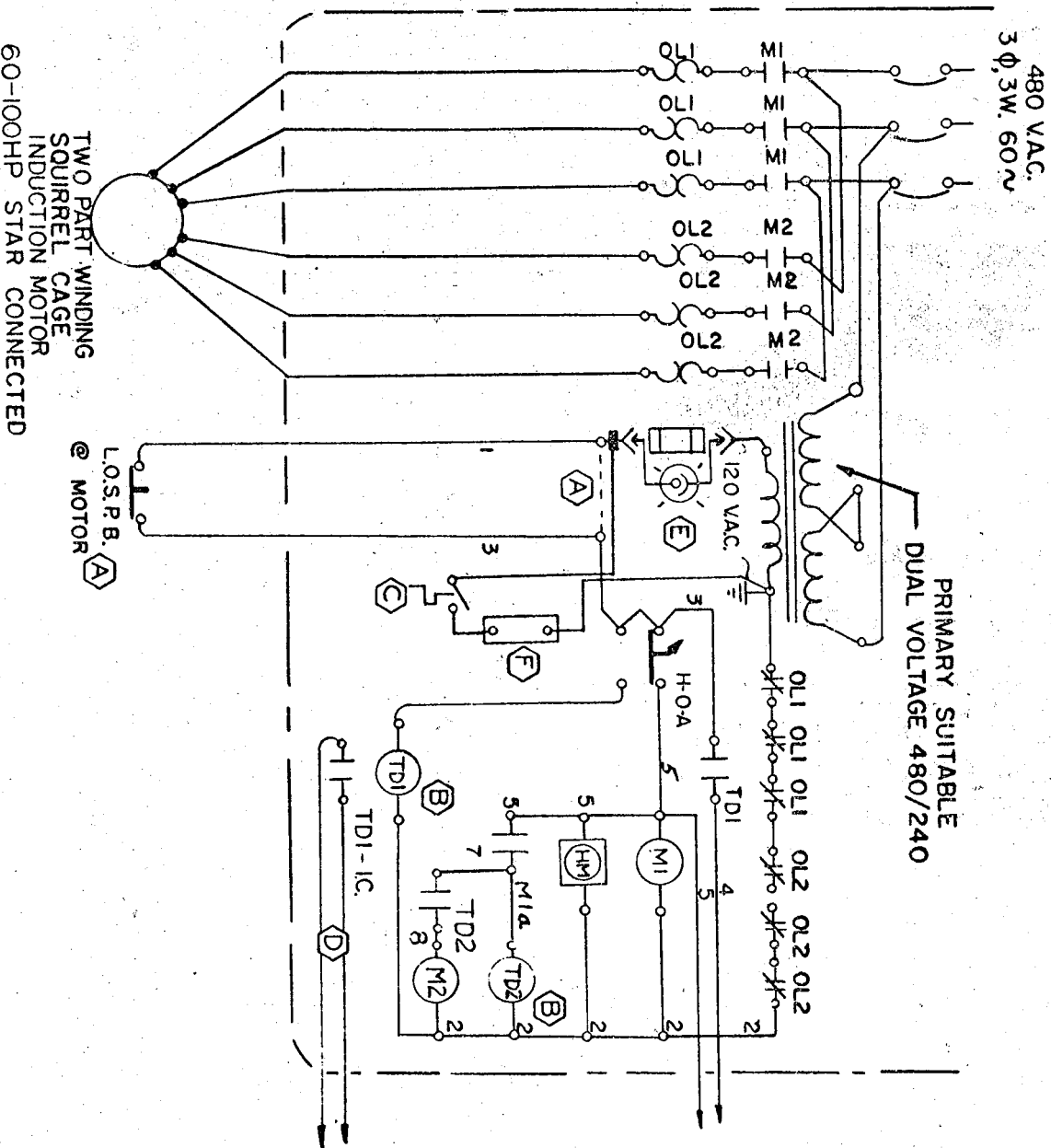

(A) FOR OUTDOOR STARTER INSTALLATIONS ONLY  
DELETE LOS. P.B. @ MOTOR & ADD JUMPER  
SHOWN

(B) TD1, TD2, PNEUMATIC TIME DELAY  
(ON ENERGIZE) RELAYS, ADJUSTABLE  
0-90 SECS. TD2 SET APPROX 4-6  
SECS. TD1 SET 10 SECS. FOR SINGLE UNIT & @  
10 SEC UNIQUE MULTIPLES FOR  
MULTIPUMP INSTALLATIONS

(C) TO FLOAT SWITCH CKT. FOR  
AUTO CONTROL

(D) FENWALL CO. TUBE TYPE CLIP MTD. THERMOSTAT SET  
100°F

(E) BLUE WIRING LOW VOLTAGE D.C.

(F) NON INDICATING FUSE FOR OUTDOOR  
SINGLE UNIT INST'NS, INDICATING  
FUSE FOR ALL OTHERS.

(G) VULCAN CO. STRIP HEATER 150 WATTS @ 120V.

(H) TO TELEMETER REMOTE  
ALARM CKT. see E-16

480 VAC.  
3  $\phi$  3W. 60  $\sim$

PRIMARY SUITABLE  
DUAL VOLTAGE 480/240

120 VAC.

H-O-A

OL1 OL1 OL1 OL2 OL2 OL2

M1 M1 M1

M2 M2 M2

OL2 OL2 OL2

TD1

TD2

M1A

M2

M2

TD1-IC

LOS.P.B. @ MOTOR

TWO PART WINDING  
SQUIRREL  
CAGE  
INDUCTION MOTOR  
60-100HP STAR CONNECTED

REDUCED

SACRAMENTO COUNTY DEPARTMENT OF PUBLIC WORKS HIGHWAY & BRIDGE DIVISION	
TWO PART WINDING CB COMBINATION STARTER 60HP-100HP, 480 VAC, 3 $\phi$ , 3W	
JANUARY '64	E-11



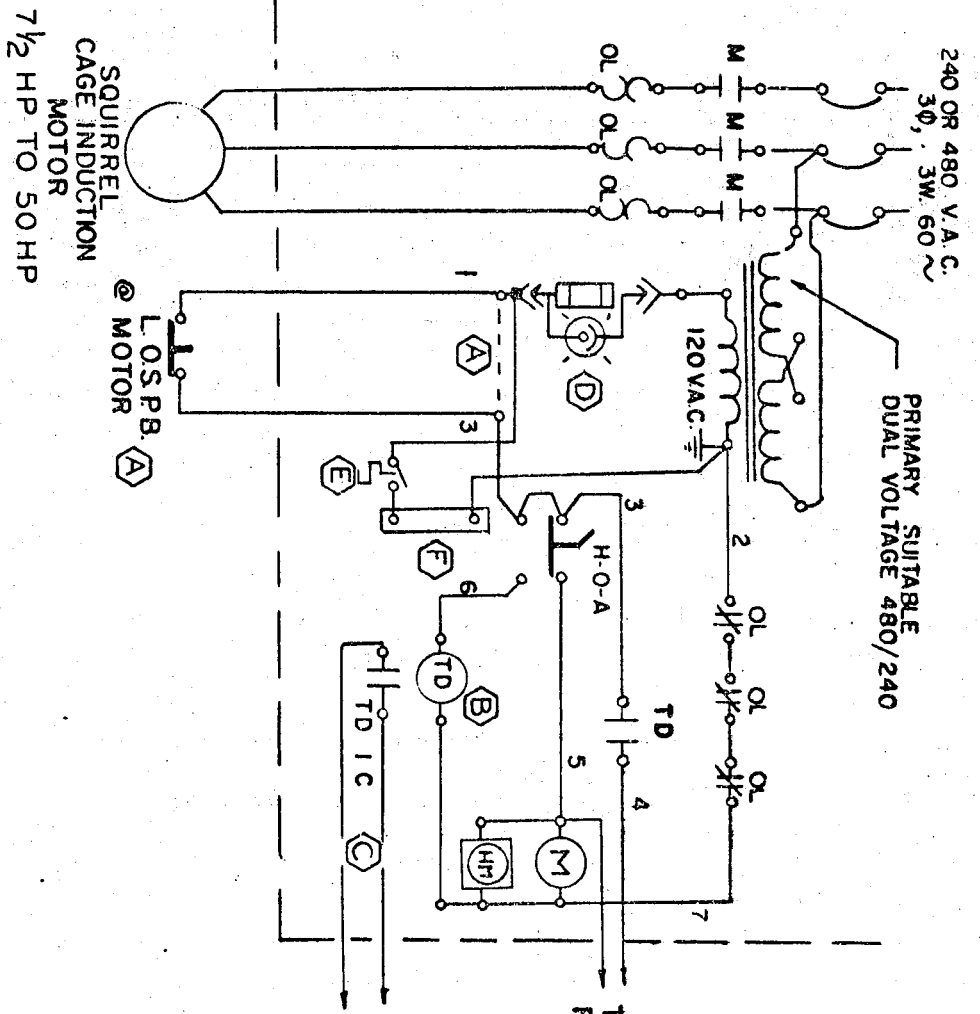

- (A) FOR OUTDOOR INSTALLATIONS ONLY INSTALL DOTTED JUMPER, & DELETE L.O.S. P.B.
- (B) PNEUMATIC TIME DELAY (ON ENERGIZED) RELAY ADJUSTABLE 0-90 SECS. SET 7 SECS FOR SINGLE UNIT, 8.7 SEC UNIQUE MULTIPLES FOR MULTIPUMP INSTALLATIONS
- (C) BLUE WIRING, LOW VOLTAGE D.C.
- (D) USE NONINDICATING FUSE WHEN MODULAR MOTOR CONTROL CENTERS ARE NOT USED. INDICATING FUSE ON ALL OTHERS.
- (E) FENWALL CO. TUBE TYPE CLIP MTD.THERMOSTAT SET 100° F
- (F) VULCAN CO. 120V. STRIP HEATER 75 WATTS. FOR 7 1/2 TO 25 HP. 100WATTS FOR 30 TO 50 HP

REDUCED

SACRAMENTO COUNTY	
DEPARTMENT OF PUBLIC WORKS	
HIGHWAY 8 BRIDGE DIVISION	
TYPICAL C.B. COMBINATION	
LINE	STARTER
7 1/2 HP - 25 HP	240 VOLTS
30 HP - 50 HP	480 VOLTS
JANUARY '64	E-12

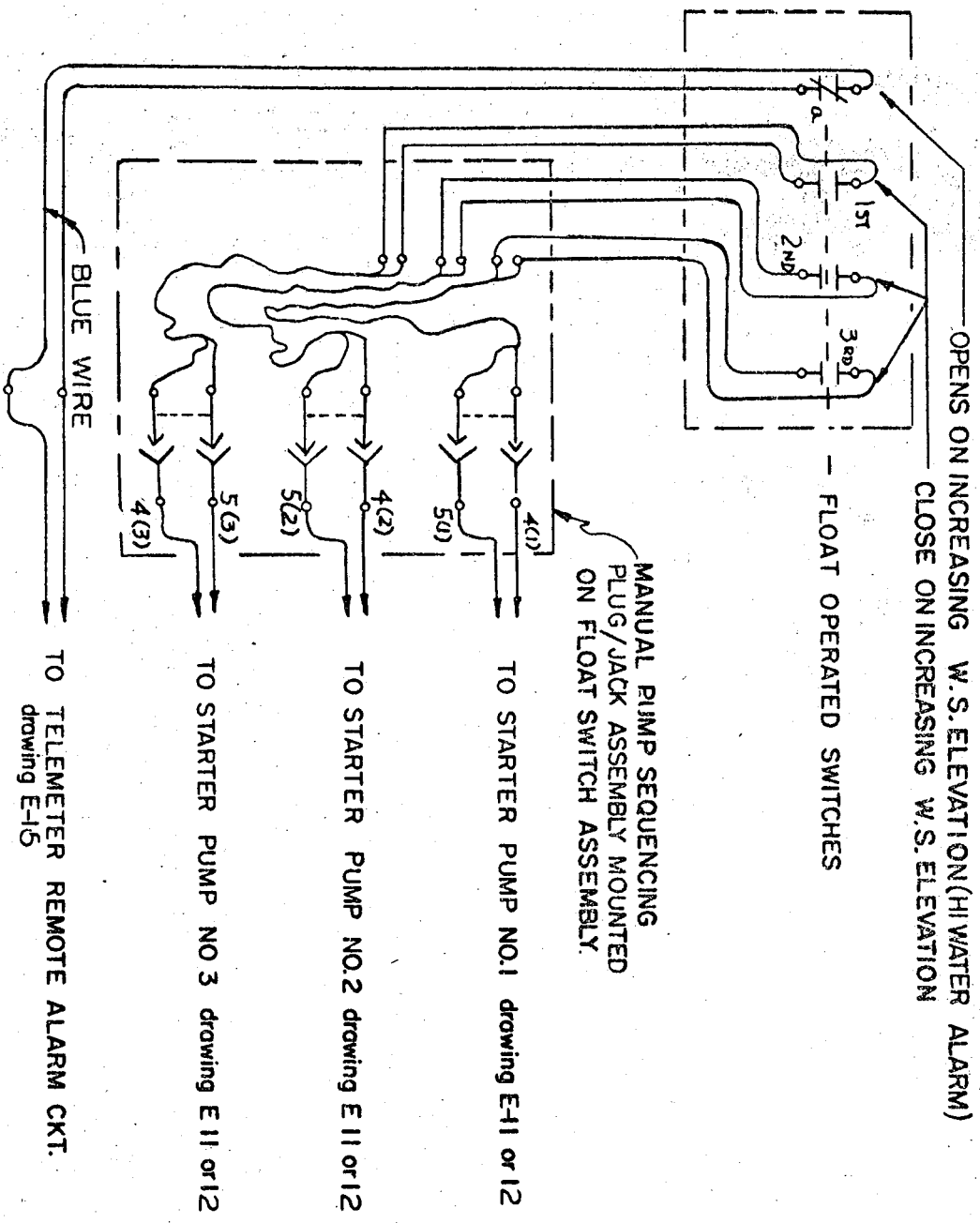

REDUCED

SACRAMENTO COUNTY	
DEPARTMENT OF PUBLIC WORKS	
HIGHWAY & BRIDGE DIVISION	
FLOAT SWITCH CIRCUIT FOR	
AUTOMATIC CONTROL OF	
THREE UNIT INSTALLATION	
(MANUAL ALTERNATION)	
JANUARY '64	E-13

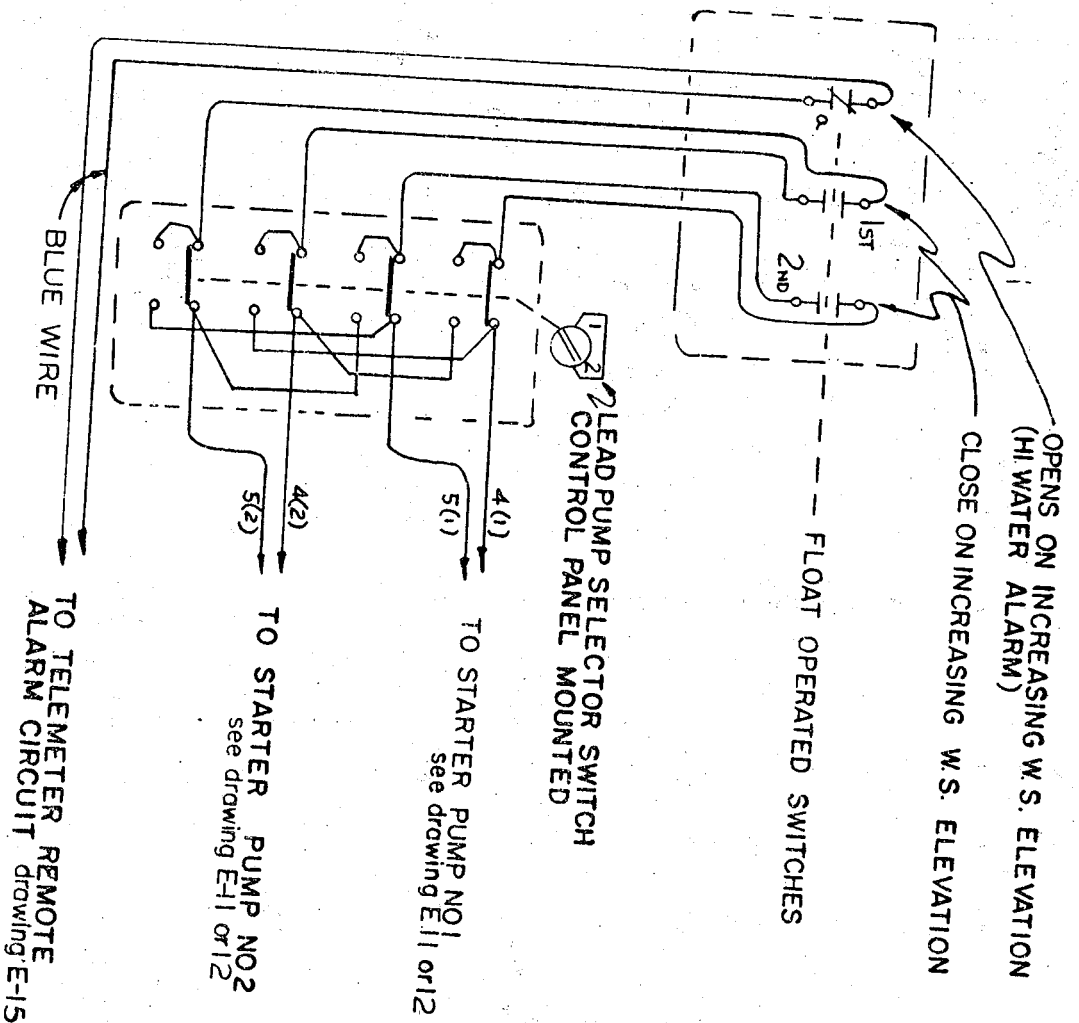

REDUCED

SACRAMENTO COUNTY	
DEPARTMENT OF PUBLIC WORKS	
HIGHWAY & BRIDGE DIVISION	
FLOAT SWITCH CIRCUIT FOR	
AUTOMATIC CONTROL OF	
TWO UNIT INSTALLATION	
(MANUAL SEL. SW. ALTERNATION)	
JANUARY 1964	E-14

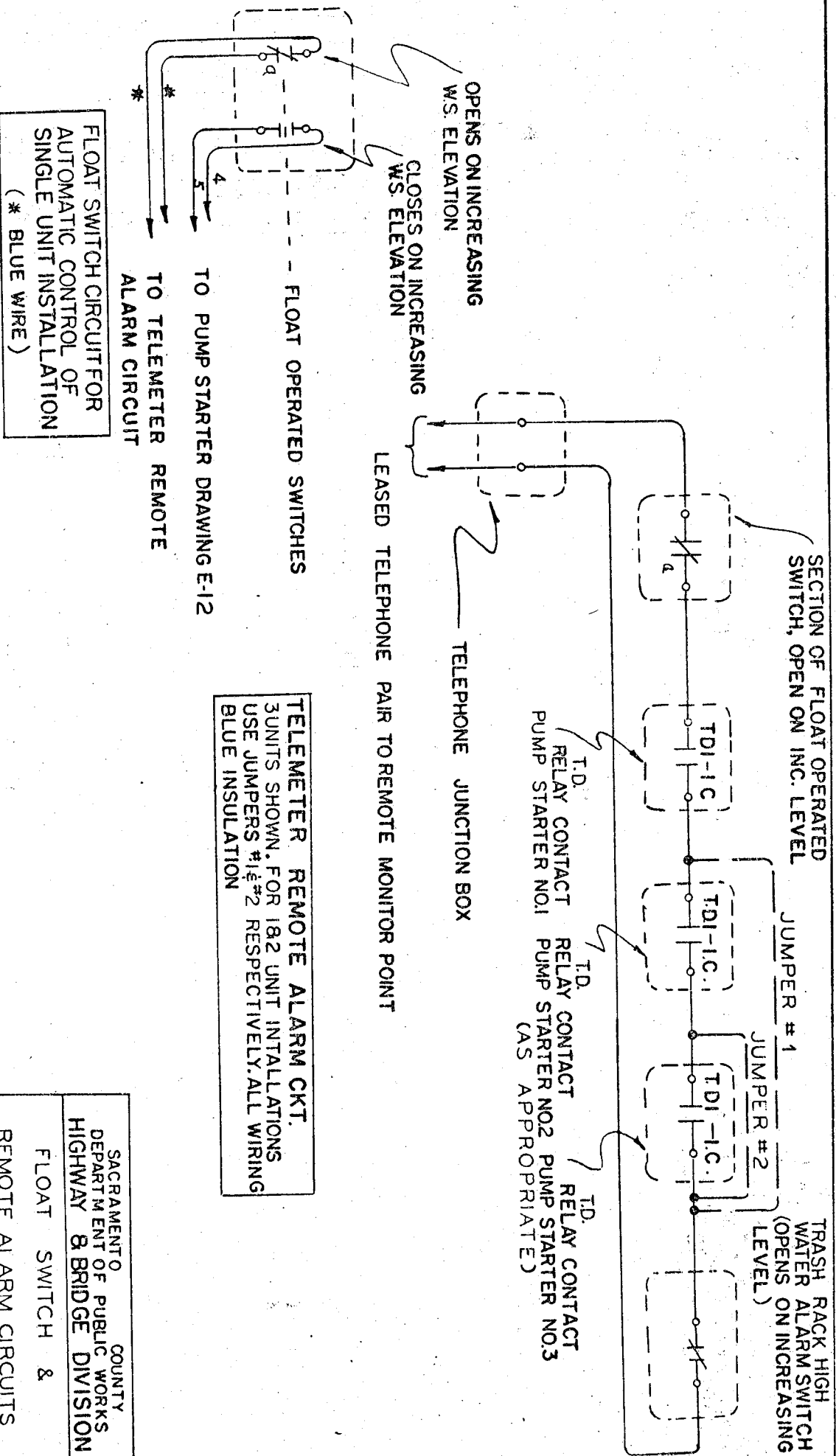

FLOAT SWITCH CIRCUIT FOR AUTOMATIC CONTROL OF SINGLE UNIT INSTALLATION (\* BLUE WIRE)

TELEMETER REMOTE ALARM CKT.  
 3 UNITS SHOWN. FOR 182 UNIT INSTALLATIONS  
 USE JUMPERS #1 & #2 RESPECTIVELY. ALL WIRING  
 BLUE INSULATION

SACRAMENTO COUNTY  
 DEPARTMENT OF PUBLIC WORKS  
 HIGHWAY & BRIDGE DIVISION  
 FLOAT SWITCH &  
 REMOTE ALARM CIRCUITS

REDUCED

JANUARY '64

E - 15

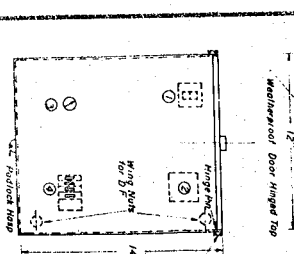
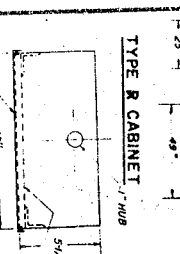
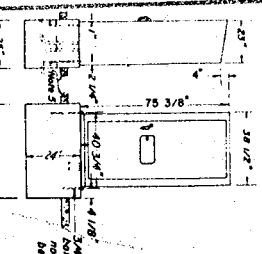
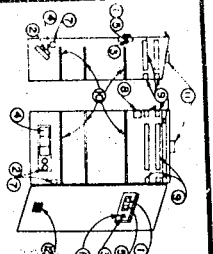

**NOTE:**

- 1. Con. of frame or 1/2" galv steel sheet
- 2. 1/2" x 2" galv steel
- 3. 1/4" x 2" galv steel
- 4. 1/4" x 2" galv steel
- 5. 1/4" x 2" galv steel

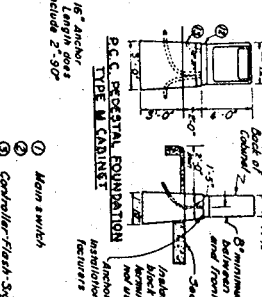
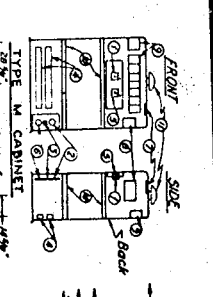

**GENERAL INSTALLATION NOTES - ALL CABINETS**

1. Foundations shall be located to provide 2"-0" minimum clearance between face of curb and back of cabinet.
2. One anchor bolt shall be located to cabinet.
3. If telephone infirmament is specified a minimum of 3 inches clearance shall be provided.
4. For telephone infirmament of 1/2" conduit shall be installed inside the steel or P.C.C. pedestal in a panel 1 inch above the floor of the cabinet to finished surface of the P.C.C. pedestal.
5. In raised or concrete raised concrete pad of 4'-0" x 4'-0" x 4'-0" surfacing shall be placed in front of each Type M, R, and G cabinet.
6. Foundation shall be specified to base of Type R cabinet & concrete foundation.

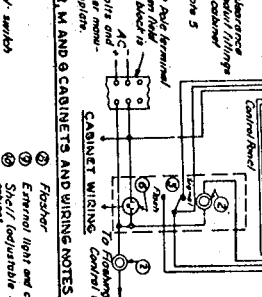
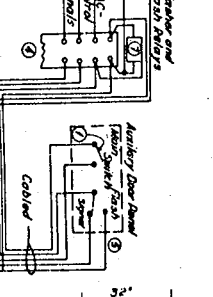

**GENERAL INSTALLATION NOTES - ALL CABINETS**

1. Foundations shall be located to provide 2"-0" minimum clearance between face of curb and back of cabinet.
2. One anchor bolt shall be located to cabinet.
3. If telephone infirmament is specified a minimum of 3 inches clearance shall be provided.
4. For telephone infirmament of 1/2" conduit shall be installed inside the steel or P.C.C. pedestal in a panel 1 inch above the floor of the cabinet to finished surface of the P.C.C. pedestal.
5. In raised or concrete raised concrete pad of 4'-0" x 4'-0" x 4'-0" surfacing shall be placed in front of each Type M, R, and G cabinet.
6. Foundation shall be specified to base of Type R cabinet & concrete foundation.

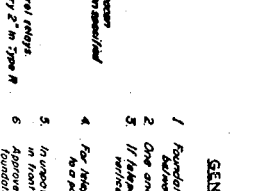
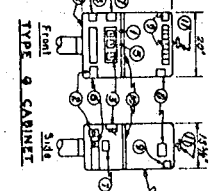

**GENERAL INSTALLATION NOTES - ALL CABINETS**

1. Foundations shall be located to provide 2"-0" minimum clearance between face of curb and back of cabinet.
2. One anchor bolt shall be located to cabinet.
3. If telephone infirmament is specified a minimum of 3 inches clearance shall be provided.
4. For telephone infirmament of 1/2" conduit shall be installed inside the steel or P.C.C. pedestal in a panel 1 inch above the floor of the cabinet to finished surface of the P.C.C. pedestal.
5. In raised or concrete raised concrete pad of 4'-0" x 4'-0" x 4'-0" surfacing shall be placed in front of each Type M, R, and G cabinet.
6. Foundation shall be specified to base of Type R cabinet & concrete foundation.

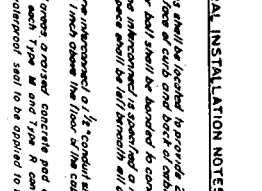
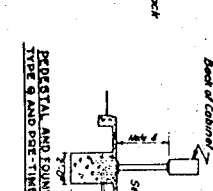

**GENERAL INSTALLATION NOTES - ALL CABINETS**

1. Foundations shall be located to provide 2"-0" minimum clearance between face of curb and back of cabinet.
2. One anchor bolt shall be located to cabinet.
3. If telephone infirmament is specified a minimum of 3 inches clearance shall be provided.
4. For telephone infirmament of 1/2" conduit shall be installed inside the steel or P.C.C. pedestal in a panel 1 inch above the floor of the cabinet to finished surface of the P.C.C. pedestal.
5. In raised or concrete raised concrete pad of 4'-0" x 4'-0" x 4'-0" surfacing shall be placed in front of each Type M, R, and G cabinet.
6. Foundation shall be specified to base of Type R cabinet & concrete foundation.

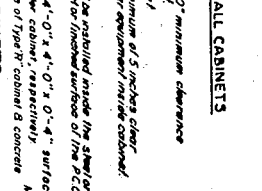
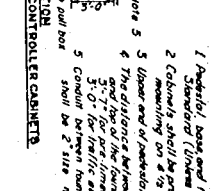

**GENERAL INSTALLATION NOTES - ALL CABINETS**

1. Foundations shall be located to provide 2"-0" minimum clearance between face of curb and back of cabinet.
2. One anchor bolt shall be located to cabinet.
3. If telephone infirmament is specified a minimum of 3 inches clearance shall be provided.
4. For telephone infirmament of 1/2" conduit shall be installed inside the steel or P.C.C. pedestal in a panel 1 inch above the floor of the cabinet to finished surface of the P.C.C. pedestal.
5. In raised or concrete raised concrete pad of 4'-0" x 4'-0" x 4'-0" surfacing shall be placed in front of each Type M, R, and G cabinet.
6. Foundation shall be specified to base of Type R cabinet & concrete foundation.

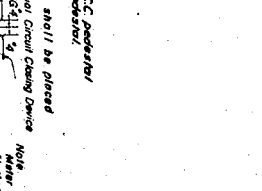
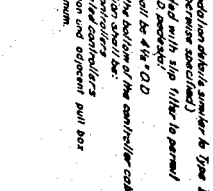

**GENERAL INSTALLATION NOTES - ALL CABINETS**

1. Foundations shall be located to provide 2"-0" minimum clearance between face of curb and back of cabinet.
2. One anchor bolt shall be located to cabinet.
3. If telephone infirmament is specified a minimum of 3 inches clearance shall be provided.
4. For telephone infirmament of 1/2" conduit shall be installed inside the steel or P.C.C. pedestal in a panel 1 inch above the floor of the cabinet to finished surface of the P.C.C. pedestal.
5. In raised or concrete raised concrete pad of 4'-0" x 4'-0" x 4'-0" surfacing shall be placed in front of each Type M, R, and G cabinet.
6. Foundation shall be specified to base of Type R cabinet & concrete foundation.

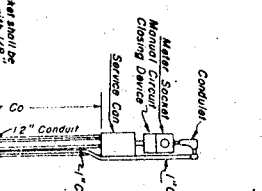

**GENERAL INSTALLATION NOTES - ALL CABINETS**

1. Foundations shall be located to provide 2"-0" minimum clearance between face of curb and back of cabinet.
2. One anchor bolt shall be located to cabinet.
3. If telephone infirmament is specified a minimum of 3 inches clearance shall be provided.
4. For telephone infirmament of 1/2" conduit shall be installed inside the steel or P.C.C. pedestal in a panel 1 inch above the floor of the cabinet to finished surface of the P.C.C. pedestal.
5. In raised or concrete raised concrete pad of 4'-0" x 4'-0" x 4'-0" surfacing shall be placed in front of each Type M, R, and G cabinet.
6. Foundation shall be specified to base of Type R cabinet & concrete foundation.

- NOTES:**
1. Position of service equipment to be determined by service utility.
  2. See Service Grounding detail.
  3. If service pole is utility owned, service shall be furnished by contractor and installed by serving utility. On county owned poles the service riser conduit shall be furnished with a service head or shall be sealed between the entrance of meter, as approved by serving utility.
  4. Service switch.
  5. Flashing beacon control.
  6. Meter socket box.

**ELECTRICAL AND TELEPHONE SERVICE DETAILS**

NO SCALE

**SERVICE GROUNDING**

NO SCALE

**STANDARD DETAILS NO. 1**

TRAFFIC SIGNAL AND HIGHWAY LIGHTING INSTALLATIONS

SCALE NONE

DEPARTMENT OF PUBLIC WORKS

STANDARD DRAWING NO. 1-1

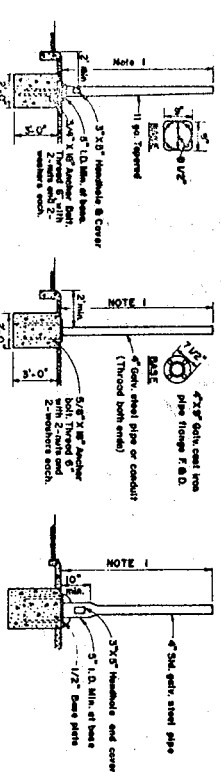

TYPE I-A STANDARD

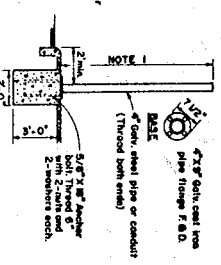

TYPE I-B STANDARD

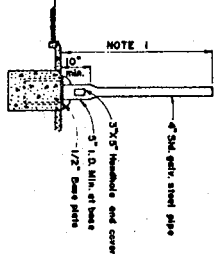

TYPE I-C STANDARD

NOTES: 1. Standards shall be 10'-0" for vehicular signals, 7'-0" for pedestrian signals and 11'-0" for vehicular signals.

SIGNAL STANDARDS

NO SCALE

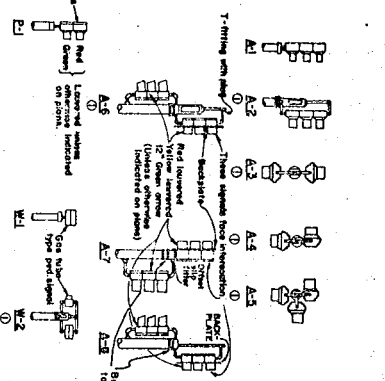

POST-TOP MOUNTINGS

BRACKET MOUNTINGS

Mounting brackets shown in this diagram are for use on standards.

SIGNALS AND MOUNTINGS

NO SCALE

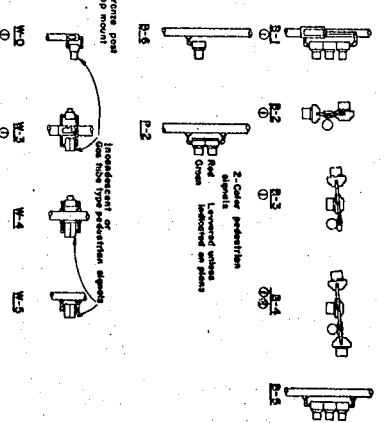

MAST ARM MOUNTING

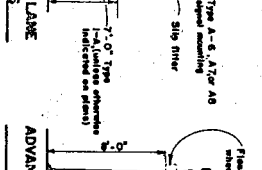
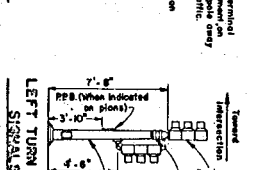
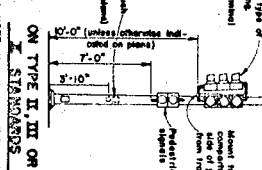
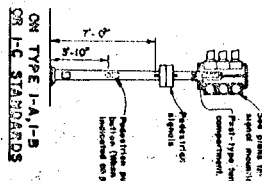
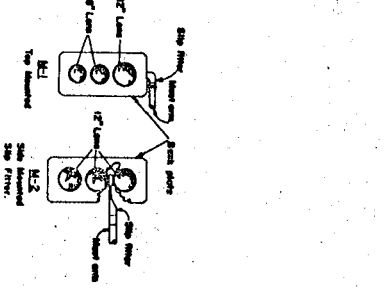

TYPICAL EQUIPMENT MOUNTING

NO SCALE

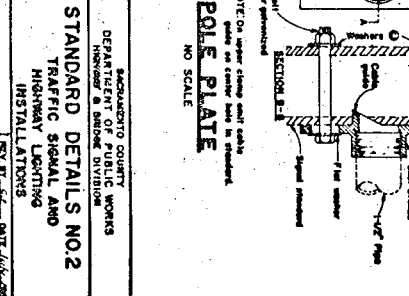
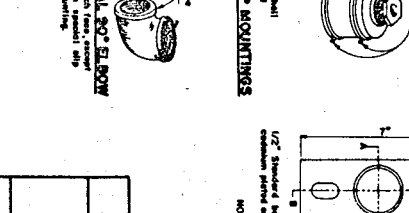
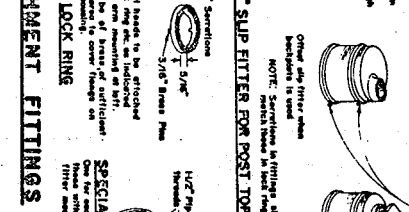
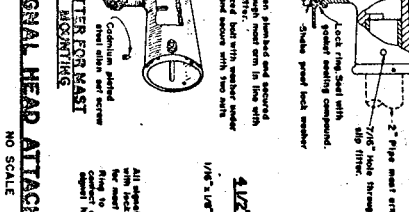
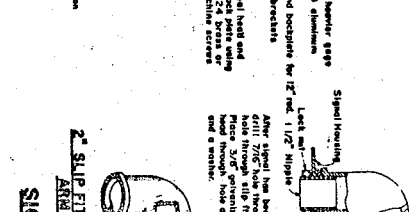
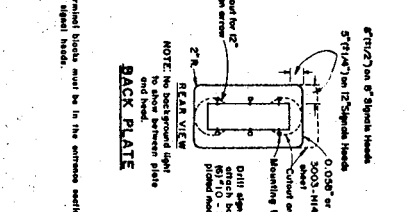
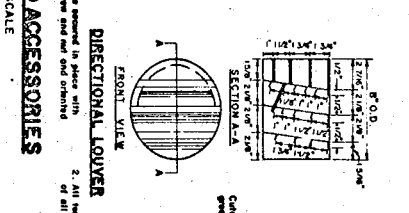
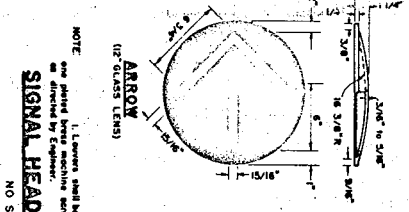

ASSOCIATED COUNTY WORKERS  
 DEPARTMENT OF PUBLIC WORKS  
 TRAFFIC SIGNAL AND  
 HIGHWAY LIGHTING  
 INSTALLATIONS  
 SCALE AS NOTED  
 REV. BY: S. L. GANT / 4/20/55  
 DRAWING NO. T.S.-2  
 DES. NO. 17-51

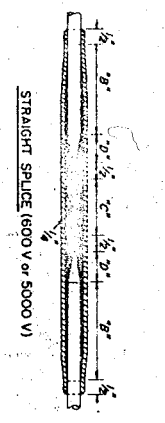

STRAIGHT SPLICE (600 V or 5000 V)

600 VOLT "1" SPRUCE

SPRUCE	ANG	SPRUCE	ANG
600 Volt 14, 12 or 10 Solid	8"	8"	1/2"
600 Volt 12, 10, 8 or 6 Stranded	2 1/2"	2 1/2"	1/2"
5000 Volt 8 Solid	3 1/4"	3 1/4"	1"
ANG	8"	8"	1"

T-SPLICE DIMENSIONS - inches

600 Volt 14, 12 or 10 Solid

6" = connector length

**PROCEDURE**

- Remove insulation from each conductor to distance  $\frac{1}{2}$  C- $\frac{1}{2}$  and pencil to dimension D (Diagram preceding).
- Trim conductors and splice connector, covering over burred cable ends.
- Clamp connector with rubber type crimping tool or crimp connector and solder.
- Insulate. Use method B for high voltage circuits unless otherwise specified.

**INSULATING METHODS**

- Low Voltage Circuits (0-500 volts)**
- Apply one coat of rubber cement and allow to dry.
  - Apply low voltage tape to a thickness equal to original insulation (two layers with electrical insulating coating if PVC tape is used).
  - High Voltage Circuits (501-5000 volts)
- Method A**
- Apply one coat of rubber cement and allow to dry.
  - Apply high voltage tape to a thickness equal to original insulation.
  - Apply two layers of low voltage tape, half lap.
- Method B**
- Apply two layers half lap of symmetrical resistant, self fusing rubber tape.
  - Apply DOT thick PVC tape to a thickness equal to original insulation.
  - Apply two layers of capacitor impregnated open meshed fabric tape and fuse in.
- GENERAL NOTES**
- Rubber tapes shall be rolled after application.
  - If PVC low voltage tape is used as a final layer, joint finished splice with electrical insulating coating.

**SPLICING**

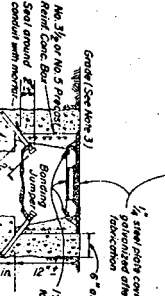
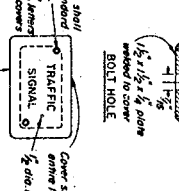
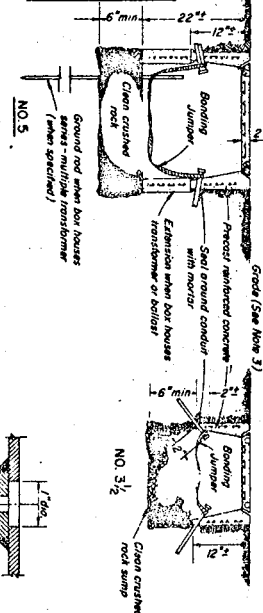
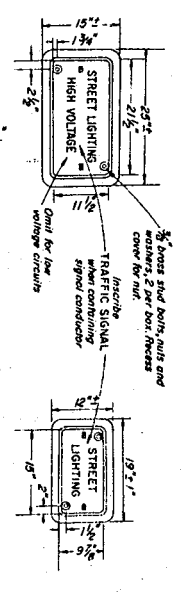

**NOTES**

- Use steel cage and anchor concrete footing as shown, when box is to be installed where subject to traffic loads. Steel cage shall have recessed non-slip pattern when box is placed in paved or sidewalk areas.
- Steel reinforcing shall be as regularly used in the standard products of the respective manufacturer.
- Top of pull boxes shall be 1' above surrounding grade or flush with the top of adjacent curb or sidewalk, or shall project above or finish grade, as directed by the engineer. Where projectable pull boxes are shown in the vicinity of curbs shall be placed adjacent to sidewalks shall be placed along side of sidewalk.
- Concrete all round pullbox when installed in traffic area.

**PULL BOXES**

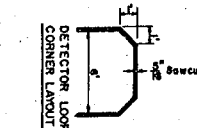
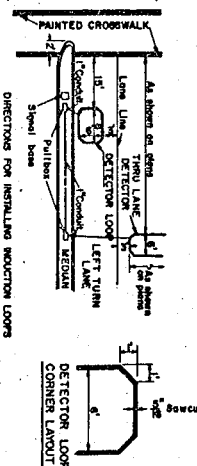

- DIRECTIONS FOR INSTALLING INDUCTION LOOPS**
- Step out the induction loop, spacing to be as shown. The cut shall be 1/2 inch wide and 1/2 inch deep for the configuration shown in the sheet when used differently on the plate.
  - The loop and lead to the receiver pullbox shall be as directed by the engineer.
  - The number of turns shall be as directed by the engineer.
  - See cuts shall be filled with epoxy, "Sealer" No. 770 as sold by National Expansion Joint Co. or equal.
  - The lead from the controller cabinet to the receiver pullbox (adjacent to the loop) shall be 4-wire shielded cable, shielded, twisted, copper, Chem-Vinyl jacket, Belden No. 84473 or equal.
  - The splice between lead and loop in the adjacent pullbox shall be a soldered wire-wrap type and be completed by use of a Scotch Com Splicing Kit as manufactured by Minnesota Mining Company.

**INDUCTION LOOP DETECTOR**

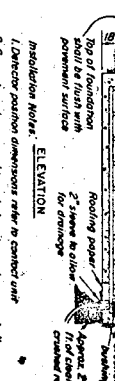
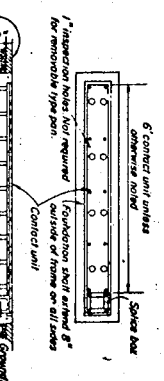
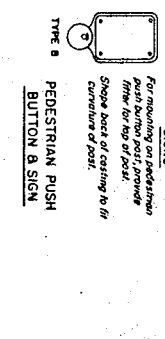
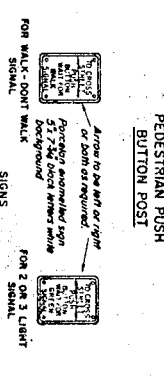
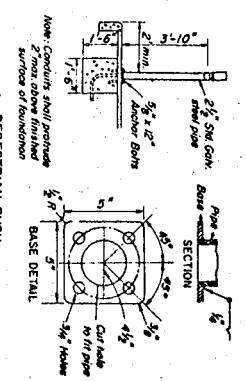

- Insulation Notes:**
- Detector position dimensions refer to contact unit.
  - Concrete under removable contact unit including part shall be finished flush with top of iron supporting pipes.
  - Detector contact unit surface shall be flush with rim of housing or no more than 1/8 inch; if rim shall be finished the same as the bottom surface of the contact unit.
  - All screws shall be tightened securely.

**PRESSURE DETECTOR**

SACRAMENTO COUNTY  
DEPARTMENT OF PUBLIC WORKS  
HIGHWAY & BRIDGE DIVISION

**STANDARD DETAILS NO. 3**  
**TRAFFIC SIGNAL AND HIGHWAY**  
**LIGHTING INSTALLATIONS**

NO SCALE REV. DATE 2-7-74 BY C-1  
DRAWING NO. T-S-3

T-S-3

# SYMBOLS

PROPOSED	EXISTING	DESCRIPTION
		Signal conductor
		Lighting conductor
		Pull box
		Non-directional pressure detector
		Directional magnetic detector
		Directional pressure detector
		Traffic signal, each arrow one-way three color
		Traffic signal one-way three-color with backplate
		Traffic signal one-way three-color with green arrow
		Traffic signal one-way three-color with red arrow
		Multi-way pedestrian signal (Type I or II standard)
		Pedestrian signal, 2 color head on 2' Type I-B (unless otherwise specified)
		Most arm traffic signal with backplate (Type II standard)
		Electrovibrator, most arm type (Type I standard)
		Electrovibrator, upright type
		Pedestrian push button on post
		Power pole
		Telephone pole
		Fire hydrant
		Flashing beacon, one-way
		Traffic signal with all colors, lowered
		R/W line
		Ultrasonic detector (Side fire type)
		Impact detector
		Inductive loop detector
		End of conductor
		Equipment location Number (1 or 2 Bands)
		Typical Markings
		B-1 Phase
		Detector location as shown on plan
		Detector Circuit

## TYPICAL BANDING OF CONDUCTOR ENDS

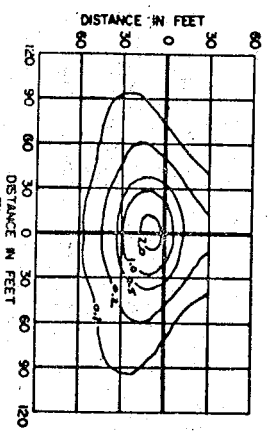

Shielded Highway Lighting Luminaire 30' mounting Height,  
20,000 Lumen Mercury Vapor Lamp  
ISOLUX LINES OF MINIMUM HORIZONTAL  
FOOT CANDLES

## INSTALLATION NOTES

### CONDUIT

1. Unless otherwise indicated, conduit in service and detector runs shall be 1 inch and all other conduit shall be 1-1/2 inch.
2. Conduit shall be installed at minimum below curb grade in sidewalk areas and 24 minimum below grade or finished surface in all other areas except that conduit installed within curbs or existing strips constructed or existing pavement may be laid on and secured to the pavement.
3. Conduit runs parallel to curbs shall be placed adjacent to back of curb, except where in conflict with existing facilities.
4. Existing underground conduit to be incorporated into new systems shall be cleaned with a mandrel and blown out with compressed air.
5. Conduit terminating in standards and pedestals shall extend 2" max above finished top of foundation and shall slope toward the standards.
6. Service risers shall be terminated with a service head or shall be sealed to prevent the entrance of water as approved by the serving utility.

### PULL BOXES

1. Pull boxes shall be No 5 except as indicated.
2. Pull boxes shown in the vicinity of curbs shall be placed adjacent to back of curb, except when in conflict with existing facilities.
3. Top of pull boxes shall be level with curb or sidewalk grade or 1" above surrounding ground when no finished grade is established.
4. Pull boxes shown adjacent to standards shall be installed against but not on roadway side of foundation.

### CONDUCTORS AND WIRING

1. Signal neutral shall be a separate #10 AWG conductor.
2. Conductors between ballasts or transformers and luminaires shall be #8 AWG, 600 volt.
3. Conductors between series-to-multiple transformers and sign fixture ballasts shall be #8 AWG, 600 volt.
4. Number of conductors indicated in signal system conduit includes three #14 AWG spurs.
5. Conductors shall be identified with bands.
6. Underground conductors to signals may be applied in gutters, as directed by engineer.
7. Neutral conductors may be spliced in pull boxes.
8. Two feet of slack shall be provided in each conductor in each pull box.

9. Connection to each terminal of a pedestrian push button shall be by a single conductor. Splices shall be made in metal pull box.
10. Color coding for wiring to pedestrian signals shall be as specified for corresponding vehicular green and red indications.
11. One side of secondary circuit of series-to-multiple transformers shall be grounded. On structures the grounding electrode shall be the conductor bottom. On structures, it shall be a 1/2" x 6" ground rod installed through bottom of pull box.

### SIGNAL EQUIPMENT

1. Pressure detectors shall be 6 feet long, non-directional, unless otherwise indicated.
2. Detector position dimensions refer to contact unit.
3. Top of detector foundation shall be level with pavement surface.
4. Detector contact with surface shall be level with rim of frame or no more than 1/8" above or below. Contact shall be dimensioned as per bottom surface of the contact unit.
5. Vehicular and pedestrian signal mountings shall be oriented so as to provide maximum horizontal clearance to adjacent roadway.

### ELECTROLYERS

1. Mercury vapor lamps shall have internal ballasts.

### FOUNDATIONS

1. Top of foundations for standards (before grading) shall be level with top of curb in curbed areas, or future grade in other areas.

SACRAMENTO COUNTY  
DEPARTMENT OF PUBLIC WORKS  
HIGHWAY & BRIDGE DIVISION  
**STANDARD DETAILS NO. 4**  
TRAFFIC SIGNAL AND  
HIGHWAY LIGHTING  
INSTALLATIONS

SCALE AS NOTED  
REV DATE July 1965  
DRAWING NO. T-3-4



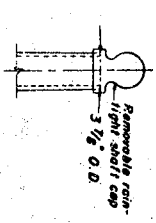

**POLE TOP**

POLE TYPE	HEIGHT & GAUGE	POLE BASE DIAMETER	BASE PLATE DIMENSIONS	BASE PL. SLOT SIZE	ANCHOR BOLTS DIMENSIONS	BASE COUPLER DIAMETER
II	20' x 10' 6"	6 5/8"	9' - 3 1/2" x 11 1/2"	1 1/2"	1" x 3 1/2"	5 1/2"
III	25' x 10' 6"	7 1/8"	11 1/2" x 11 1/2"	1 1/2"	1" x 3 1/2"	5 1/2"
III-a	30' x 10' 6"	8 1/8"	11 1/2" x 11 1/2"	1 1/2"	1" x 3 1/2"	5 1/2"
IV	35' x 10' 6"	8 1/2"	12 1/2" x 11 1/2"	1 1/2"	1 1/4" x 4 1/2"	11 1/2"
V	50' x 10' 6"	9 1/4"	12 1/2" x 11 1/2"	1 1/2"	1 1/4" x 4 1/2"	11 1/2"
V-a	35' x 10' 6"	8 1/4"	12 1/2" x 11 1/2"	1 1/2"	1 1/4" x 4 1/2"	11 1/2"

**BASE AND ANCHOR BOLT SCHEDULE**

\* Make 1/16" acceptable if fabricated from steel sheet of 40,000 psi minimum yield.  
 \*\* Length indicated does not include required 4'-30" bend.

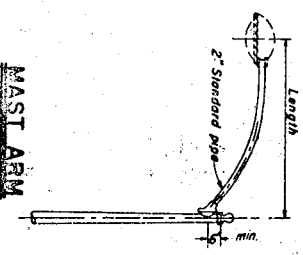

**MAST ARM**

3"x5" Hand hole, reinforced with No. 3 rebar, 1/2" wide with 4"x6" No. 4 bars, cover plate, located in some quadrants as mast arm.

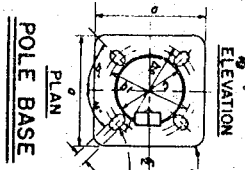

**POLE BASE**

**TIE RODS**

- All traffic signal mast arms and mast arm luminaires shall be equipped with standard pipe tie rods with welded 5/8" round bolt tops on each end, threaded 6".
- Pipe tie rods shall be 3"x4" for most arms up to 15'-0" and 1" for most arms longer than 15'-0", with a min. 4" x 8" of threads.

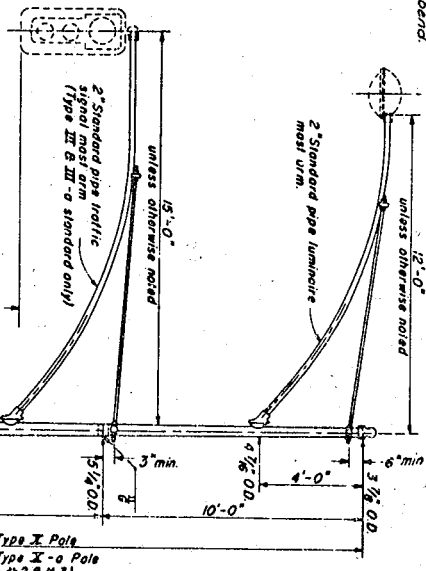

30'-0" Type III & Type X Pole  
 35'-0" Type III-a & Type X-a Pole  
 (See Table B Notes #2 & M.3)

NOTE: Omit lower mast arm from Type X & X-a poles.

**TYPE III & III-a OR TYPE X & X-a**  
 ELEVATION  
 (TYPE III SHOWN)  
 SCALE: 3/8" = 1'-0"



**MAST ARM TIE RODS AND CROSS ARM**

(Use for mast arms in excess of 8' in length)

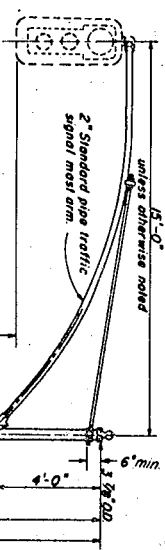

25'-0" Type II-a (See Table B Note #4)

NOTE: Top two inches of foundation to be poured level with sidewalk finish

**TYPE II & II-a**  
 ELEVATION  
 (TYPE II SHOWN)  
 SCALE: 3/8" = 1'-0"

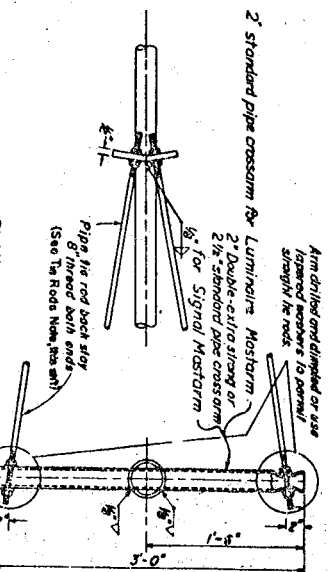

**POLE SPLICE**

No. 10 gauge at each welded joint.

**CALIF - TYPE STANDARDS**

**GENERAL AND INSTALLATION NOTES**

- All shorts and mast arms shall be galvanized. Bolt screws, nuts, washers and tie rods shall be galvanized.
- The lower 5' length of a 33' Type X-a pole shall consist of a 5' - 10 gauge tapered section (8 O.D. to 6 1/8 O.D.) butt welded to the lower end of a 30' Type X pole.
- The lower 5' length of a 33' Type X-a pole shall consist of a 5' - 10 gauge tapered section (8 O.D. to 6 1/8 O.D.) butt welded to the lower end of a 30' Type X pole.
- The lower 5' length of a 33' Type X-a pole shall consist of a 5' - 10 gauge tapered section (8 O.D. to 6 1/8 O.D.) butt welded to the lower end of a 30' Type X pole.

- Luminaire mast arms shall be so curved that when installed are tangent to pole (luminaire and steel not be below top of pole or more than 1/8" - 6" above).
- The top 3" of the mast arm shall be straight and shall be finished with 1/2" diameter or traffic signal attached.
- Connection between mast arm and pole shall be made by means of a ringbolt socket of a design permitting single removal of a mast arm and providing a chased outlet for electrical conductors.

**ANCHOR BOLTS**  
 1. Each standard shall be supplied with 4 anchor bolts.  
 2. Each anchor bolt shall be provided with 6" of thread and a 4'-30" bent end.  
 3. Threads may be cut or rolled. Bolts shall be galvanized or plated after threads are formed.  
 4. One anchor bolt shall be bonded to conduit.

SACRAMENTO COUNTY  
 DEPARTMENT OF PUBLIC WORKS  
 HIGHWAY & BRIDGE DIVISION

**STANDARDS**  
 CALIFORNIA TYPE  
 20ft., 25ft., 30ft., 35ft., Pole Heights  
 SCALE AS NOTED

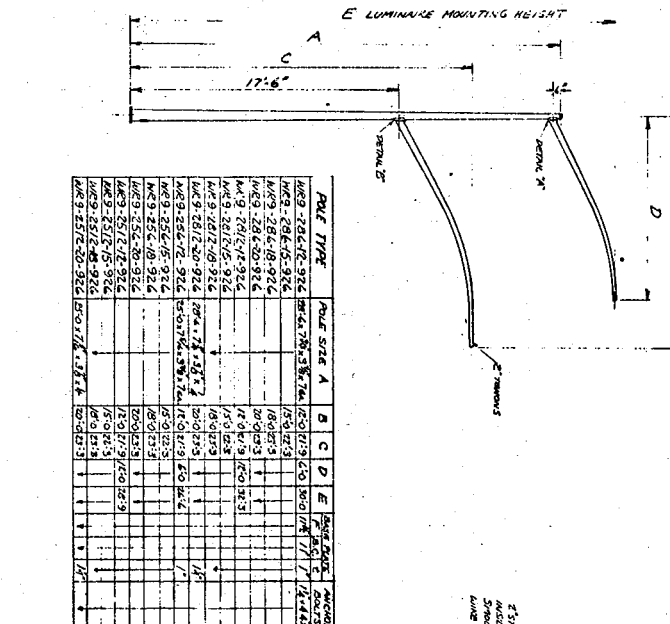
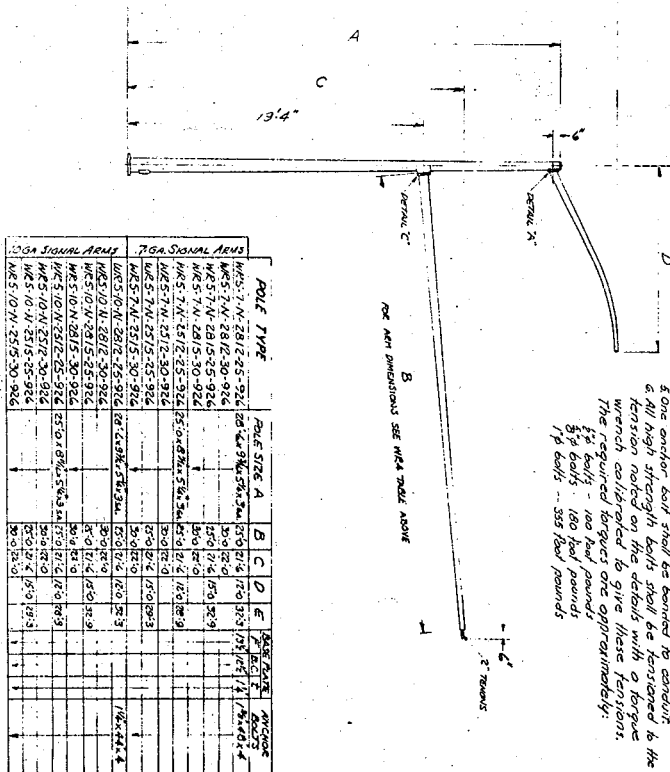
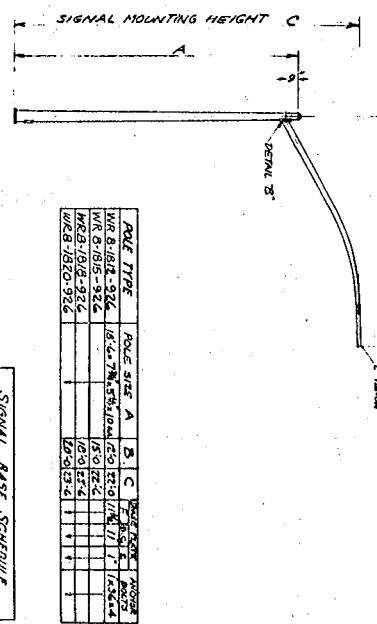
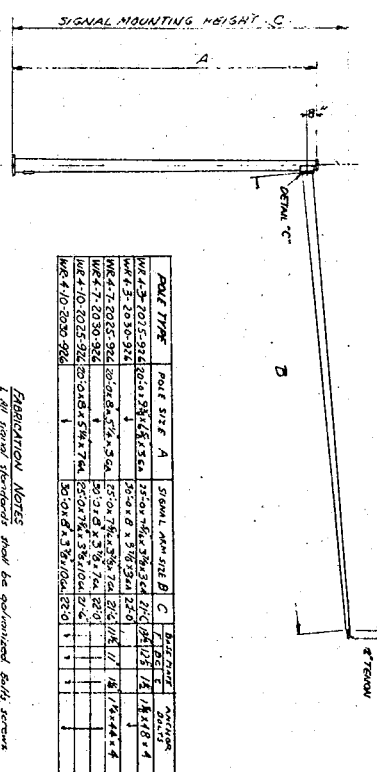

**ERECTOR NOTES**  
 1. All signal standards shall be galvanized both screws  
 nuts and washers shall be galvanized or cadmium plated  
 2. Each standard shall be supplied with 4 anchor bolts  
 3. Each anchor bolt shall be provided with 6" threaded  
 end and 4" galv end and shall be furnished with two  
 nuts and two washers.  
 4. Washers may be cut or rolled. Bolts shall be galvanized  
 or plated after threads are formed.  
 5. One anchor bolt shall be secured by conduit  
 6. All high strength bolts shall be identified to the  
 tension marked on the details with a torque  
 wrench calibrated to give these torques.  
 The 1/2" square nut type one option only.  
 5/8" bolts - 180 foot pounds  
 3/4" bolts - 335 foot pounds  
 1" bolts - 555 foot pounds

SIGNAL TYPE	BASE TYPE	SCHEDULE
WR 2	FORCED CONCRETE	30 X 30 X 150 DEEP
WR 3	FORCED CONCRETE	30 X 30 X 150 DEEP
WR 4	FORCED CONCRETE	30 X 30 X 150 DEEP
WR 5	FORCED CONCRETE	30 X 30 X 150 DEEP

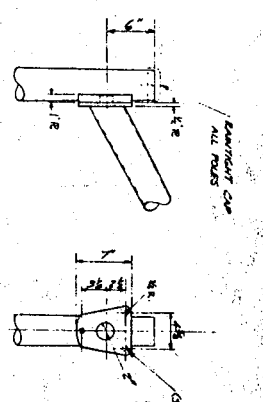
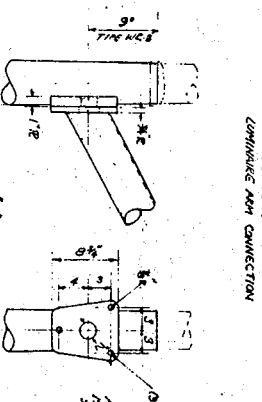
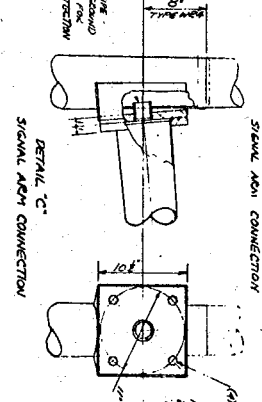
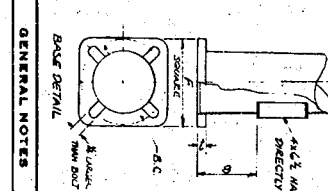

**SPECIAL STANDARDS**  
**W.R. TYPE**

SACRAMENTO COUNTY  
 DEPARTMENT OF PUBLIC WORKS  
 STANDARD & SPECIFICATIONS DIVISION

DATE	REVISIONS
7/15/53	ANCHOR BOLT REVISION

SCALE: NONE  
 DRAWING  
 T.S. 6  
 Rev. Date: July, 1953



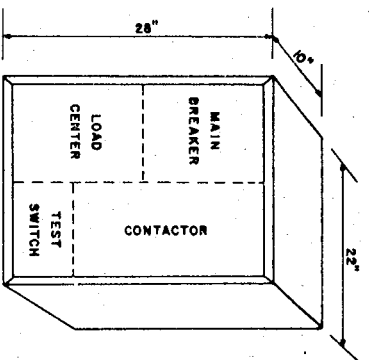

**SERVICE CAN**

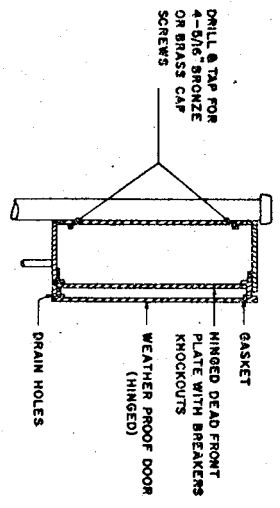

NOTE: CAN SHALL BE MADE OF 12 GA. GALV. STEEL.

**SECTION A-A**

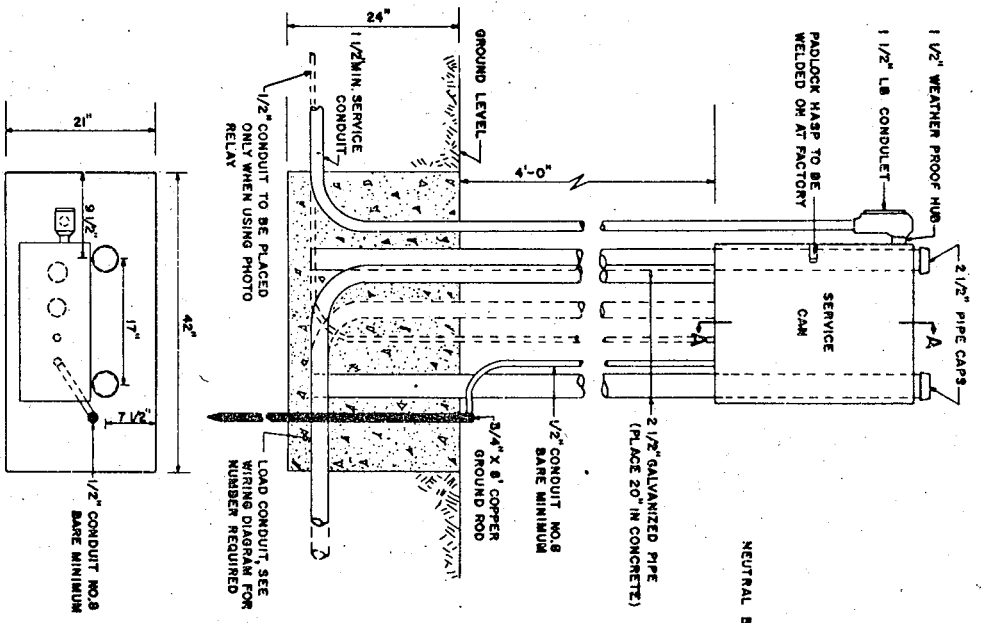

**PEDESTAL-SERVICE CAN**

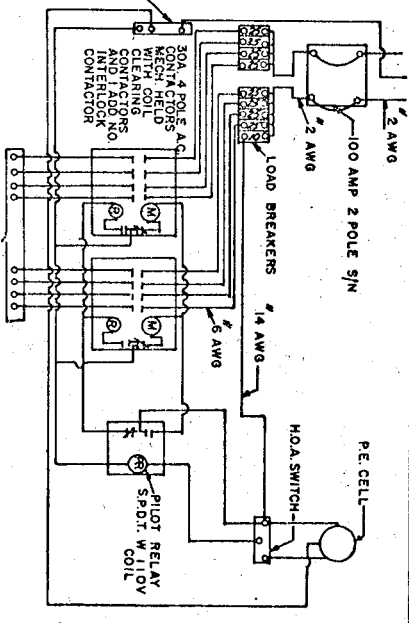

**TYPICAL 100 AMP SERVICE**  
 FOR SMALLER SERVICE THAN SHOWN, THE UNUSED COMPONENTS SHALL BE REMOVED. SERVICE SIZE MAY BE REDUCED ACCORDINGLY.

- (M) PICK UP COIL
- (R) RELEASE COIL
- ⊘ NORMALLY CLOSED CONTACTS
- ⊚ NORMALLY OPEN CONTACTS

**WIRING DIAGRAM**

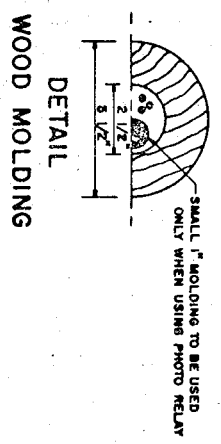

**WOOD MOLDING**

SACRAMENTO COUNTY  
 DEPARTMENT OF PUBLIC WORKS  
 HIGHWAY & BRIDGE DIVISION  
**STREET LIGHTING**  
 STANDARD  
 CONSTRUCTION DETAILS

REDUCED

RECOMMENDED: *[Signature]*  
 TRAFFIC ENGINEER

APPROVED: *[Signature]*  
 DIRECTOR OF PUBLIC WORKS

NO SCALE  
 DATE: 1-18-60, 8-5-64  
 DRAWN BY: L.F.O.E. REV. C7

L-1

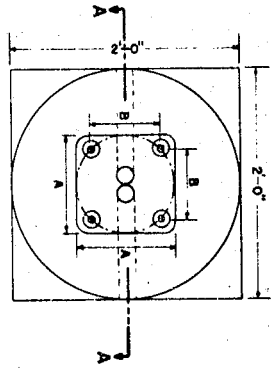

NOTE: DIMENSIONS "A" & "B" TO BE SPECIFIED BY MANUFACTURER OF APPROVED POLE.

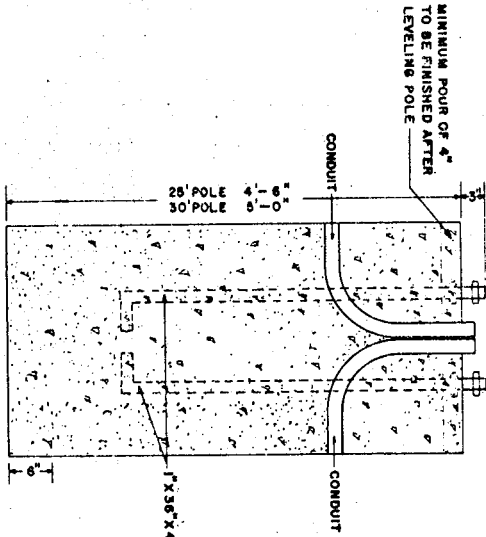

SECTION A-A

CONCRETE FOUNDATION FOR POLE

REVISED

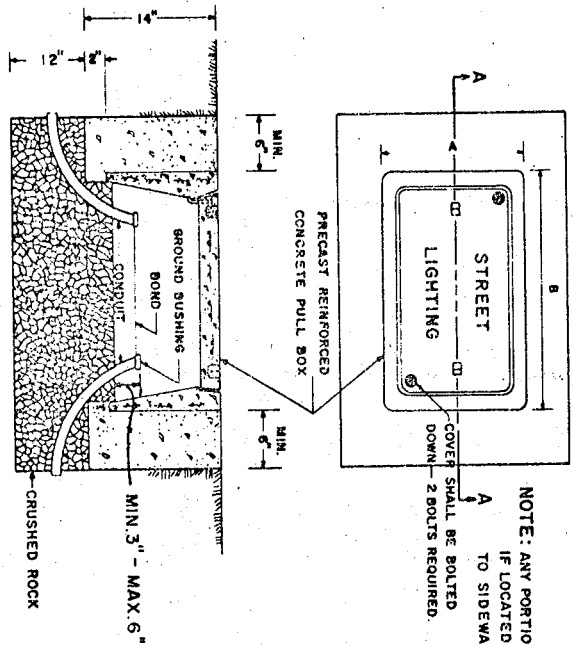

SECTION A-A  
CONCRETE PULL BOX

PULL BOX DIMENSIONS		
STATE HWY. PULL BOX	A	B
TYPE	3 1/2	18"
TYPE	5	15"
		25"

RECOMMENDED: *James C. Day*  
TRAFFIC ENGINEER

APPROVED: *A. R. Stuebler*  
DIRECTOR OF PUBLIC WORKS

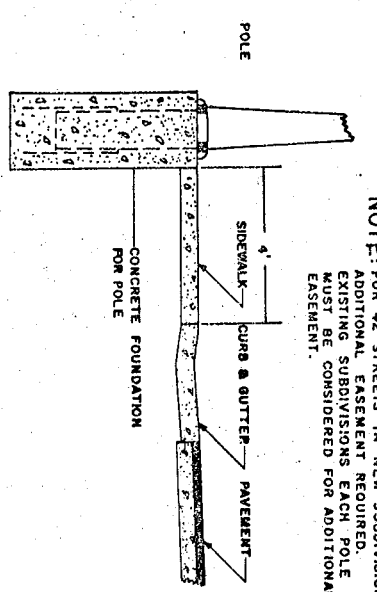

CROSS SECTION OF STREET,  
POLE & POLE FOUNDATION

SACRAMENTO COUNTY  
DEPARTMENT OF PUBLIC WORKS  
HIGHWAY & BRIDGE DIVISION  
STREET LIGHTING  
STANDARD  
CONSTRUCTION DETAILS

NO SCALE:  
DATE: 1-19-60, 8-5-64  
DRAWN BY: J.F.O.B. REV. C

Carefully placed  
backfill, No special  
Compaction required.

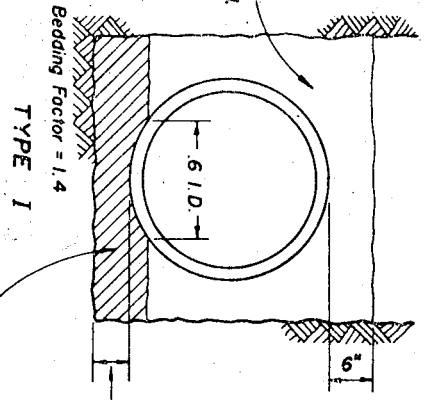

TYPE I

Imported material:  
100% passing 3/4" sieve  
min. sand equivalent of 50

Imported material:  
100% passing 3/4" sieve  
min. sand equivalent of 50

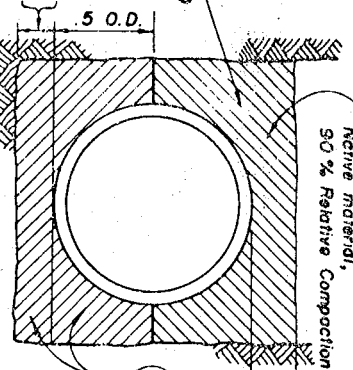

TYPE II

Imported material:  
100% passing 3/4" sieve,  
Less than 10% Passing  
No. 8 sieve.

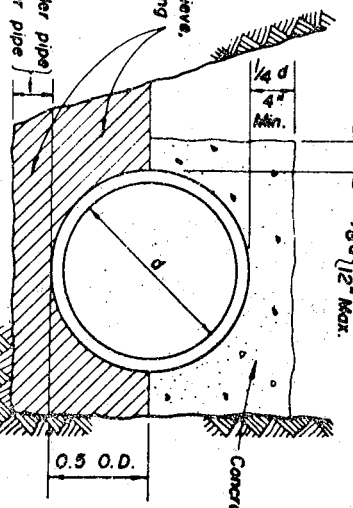

TYPE IV

(To be used only with written approval  
of Chief, Utilities Division)

Imported material:  
100% passing 3/4" sieve,  
Less than 10%  
Passing No. 8 sieve.

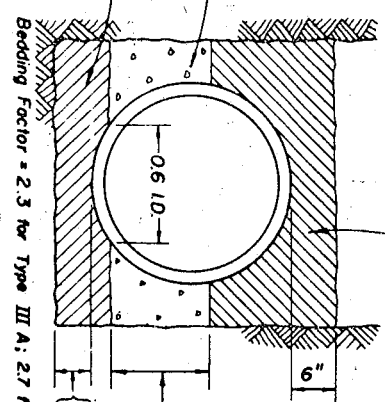

TYPE III

Type III A = 0.9 O.D.  
Type III B = 0.75 O.D.

3" For 10" or smaller pipe  
4" For 12" or larger pipe

COMPLETE ENCASUREMENT DETAIL

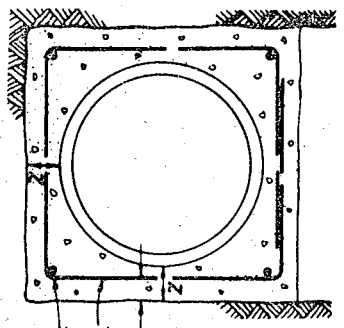

Z = 4" Min. for Service Sewer  
6" Min. for all Sewer Pipes

RECOMMENDED

*W. J. ...*  
CHIEF, UTILITIES DIVISION

APPROVED

*A. R. ...*  
DIRECTOR OF PUBLIC WORKS

SACRAMENTO COUNTY  
DEPARTMENT OF PUBLIC WORKS  
UTILITIES DIVISION

PIPE BEDDING

8

INITIAL BACKFILL

NO SCALE  
DATE: MARCH, 1965  
DRAWN BY: K. L. G

910 - S - 1

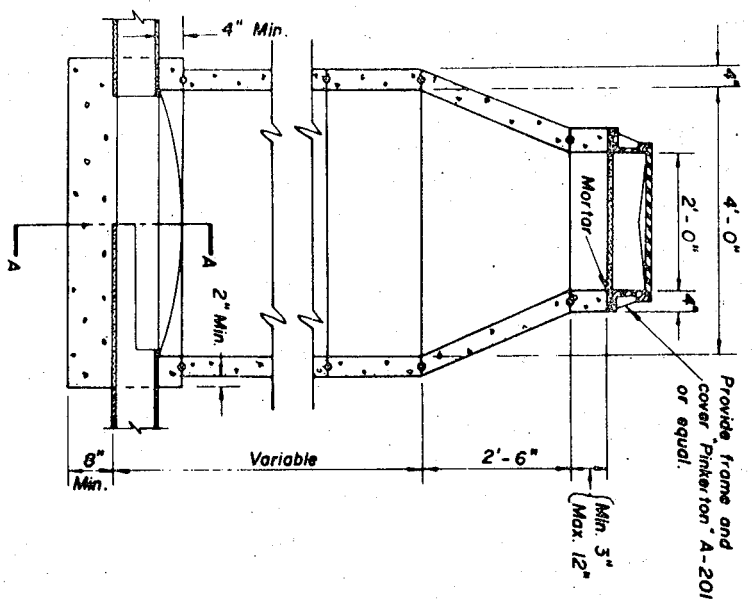

# STANDARD MANHOLE 48"

For Sanitary Sewers 24" diameter or less.

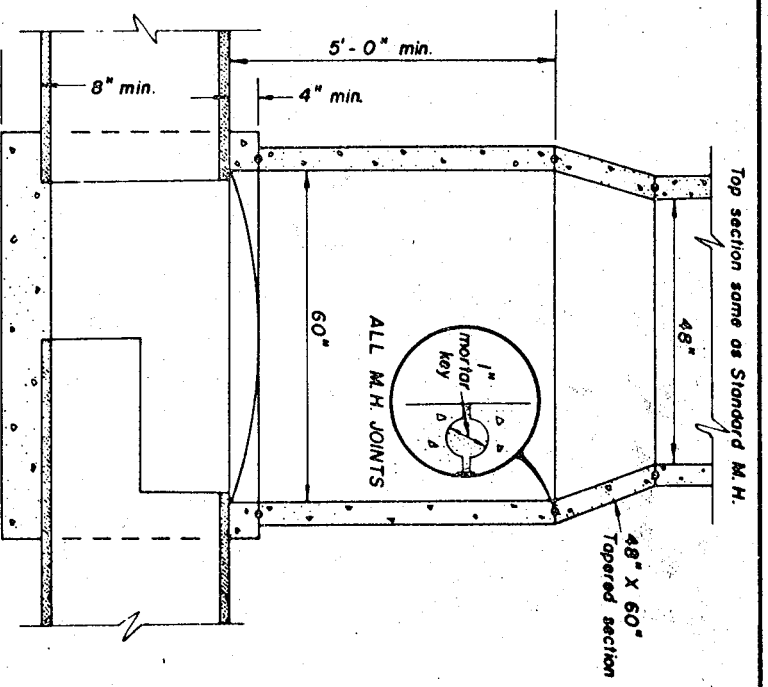
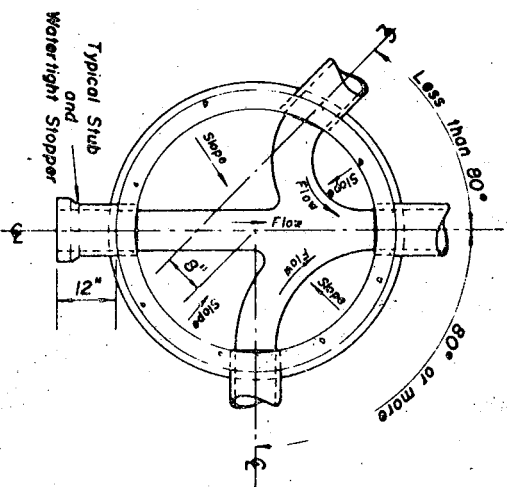
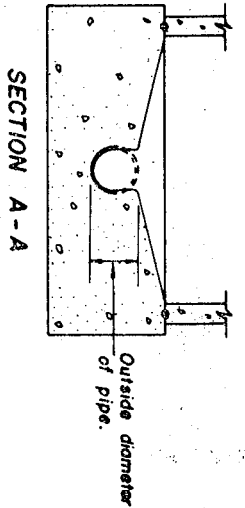

# 60" MANHOLE

## PLAN VIEW OF MANHOLE SHOWING INTERSECTING SEWERS

SACRAMENTO COUNTY  
DEPARTMENT OF PUBLIC WORKS  
UTILITIES DIVISION

# MANHOLES

NO SCALE  
DATE: MARCH, 1965  
DRAWN BY: K. L. G.

- General Notes:
1. Class A concrete shall be used for Manholes which are greater than 10' in depth.
  2. Pipe may stop at inside face of Manhole or may be continuous thru Manhole. If pipe laid continuous, top half shall be broken away after base is poured.
  3. Provide 4 holes 1 1/2" - 2 inches in diameter at 50° in lower lip of cover frame.

RECOMMENDED

CHIEF, UTILITIES DIVISION

APPROVED

*[Signature]*  
DIRECTOR OF PUBLIC WORKS

910-S-2

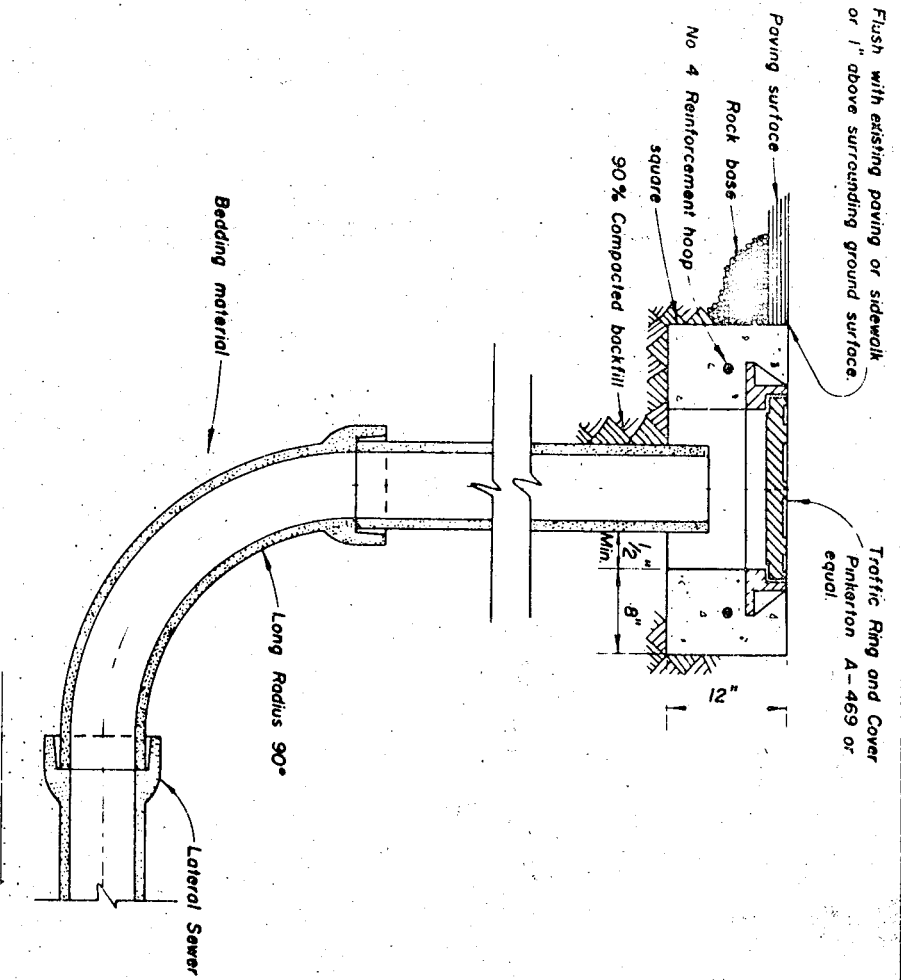

### FLUSHING BRANCH

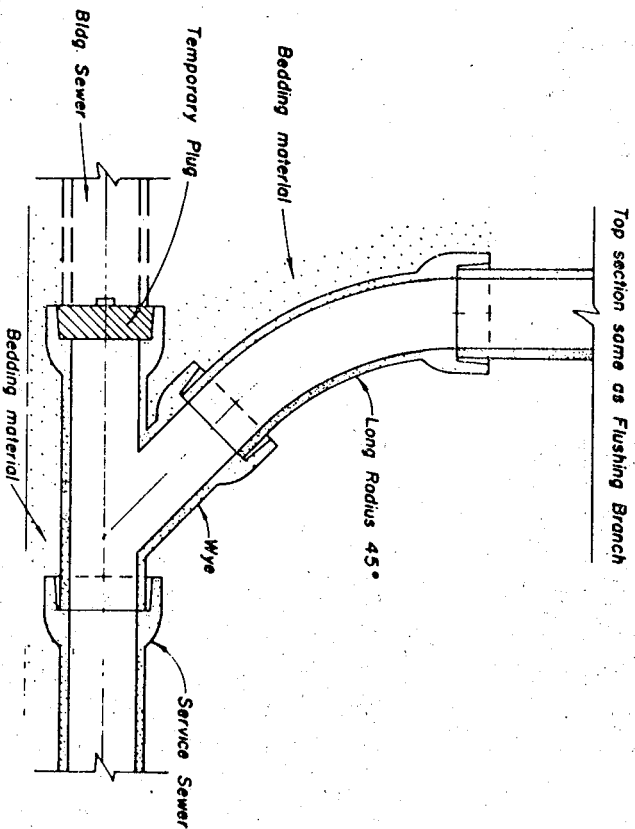

### CLEANOUT TO GRADE

NOTE  
 All pipe and fittings shall be the same size and material as the horizontal pipe to which they connect. Joint shall be as specified for the type of pipe used.

RECOMMENDED

*K. L. G.*  
 CHIEF, UTILITIES DIVISION

APPROVED

*A. P. Kieper*  
 DIRECTOR OF PUBLIC WORKS

SACRAMENTO COUNTY  
 DEPARTMENT OF PUBLIC WORKS  
 UTILITIES DIVISION

CLEANOUT TO GRADE

8

FLUSHING BRANCH

NO SCALE  
 DATE MARCH, 1965  
 DRAWN BY K. L. G.

910 - S - 3



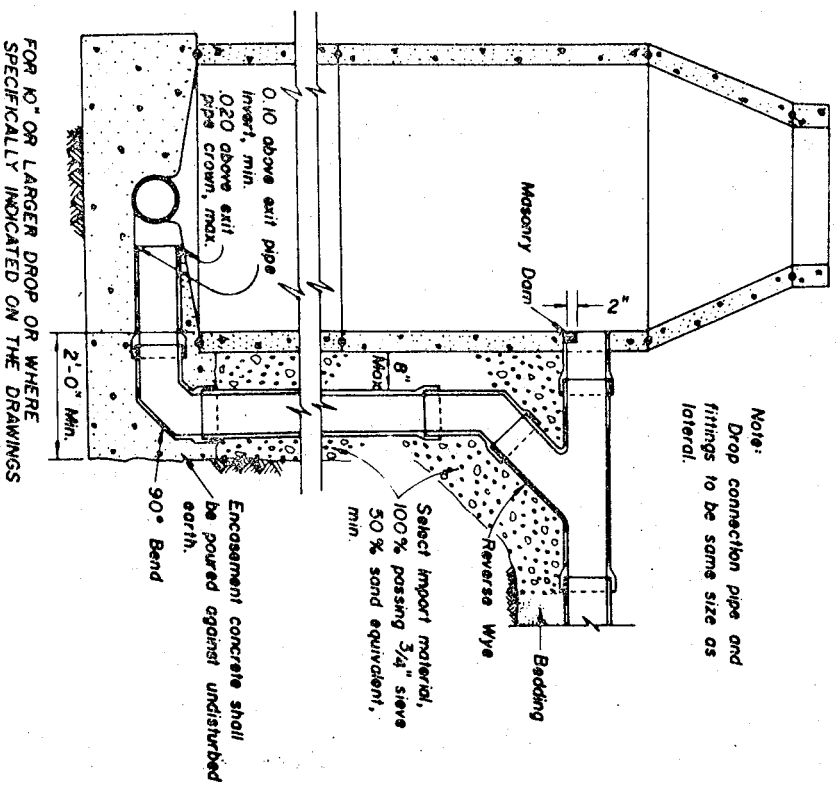

Note:  
Drop connection pipe and fittings to be same size as lateral.

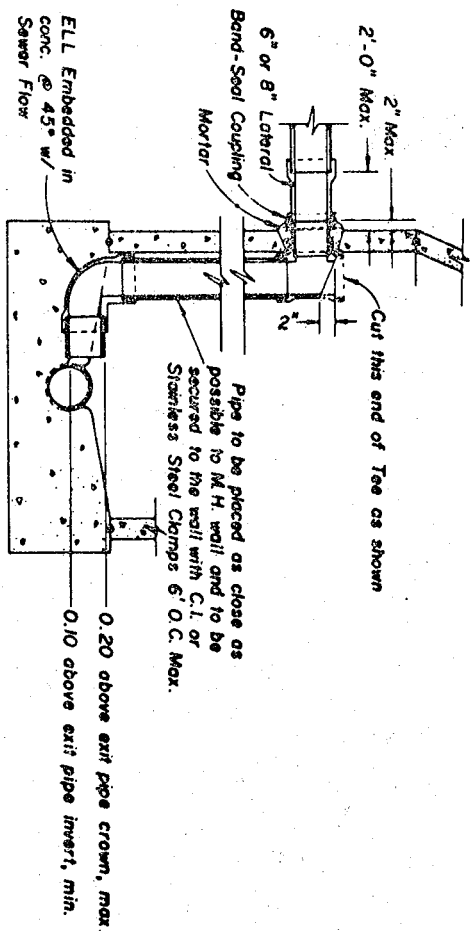

**OUTSIDE DROP CONNECTION**

FOR 10" OR LARGER DROP OR WHERE SPECIFICALLY INDICATED ON THE DRAWINGS

**INSIDE DROP CONNECTION**

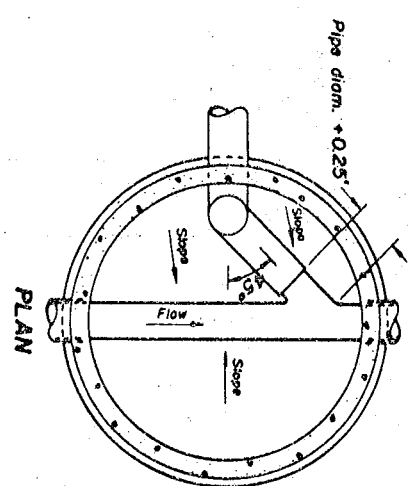

Note:  
1. All inside Drop piping to be PVC or Mod. Styrene of quality equal to "Corlon D Sewer Pipe."  
2. Cement oil joints.  
3. Drop Connection pipe and fittings to be same size as Lateral.

SACRAMENTO COUNTY  
DEPARTMENT OF PUBLIC WORKS  
UTILITIES DIVISION

**DROP CONNECTIONS**

RECOMMENDED

*W. L. ...*  
CHIEF, UTILITIES DIVISION

APPROVED *A. E. ...*  
DIRECTOR OF PUBLIC WORKS

NO SCALE  
DATE: MARCH, 1965  
DRAWN BY: K. L. G.

910-S-4

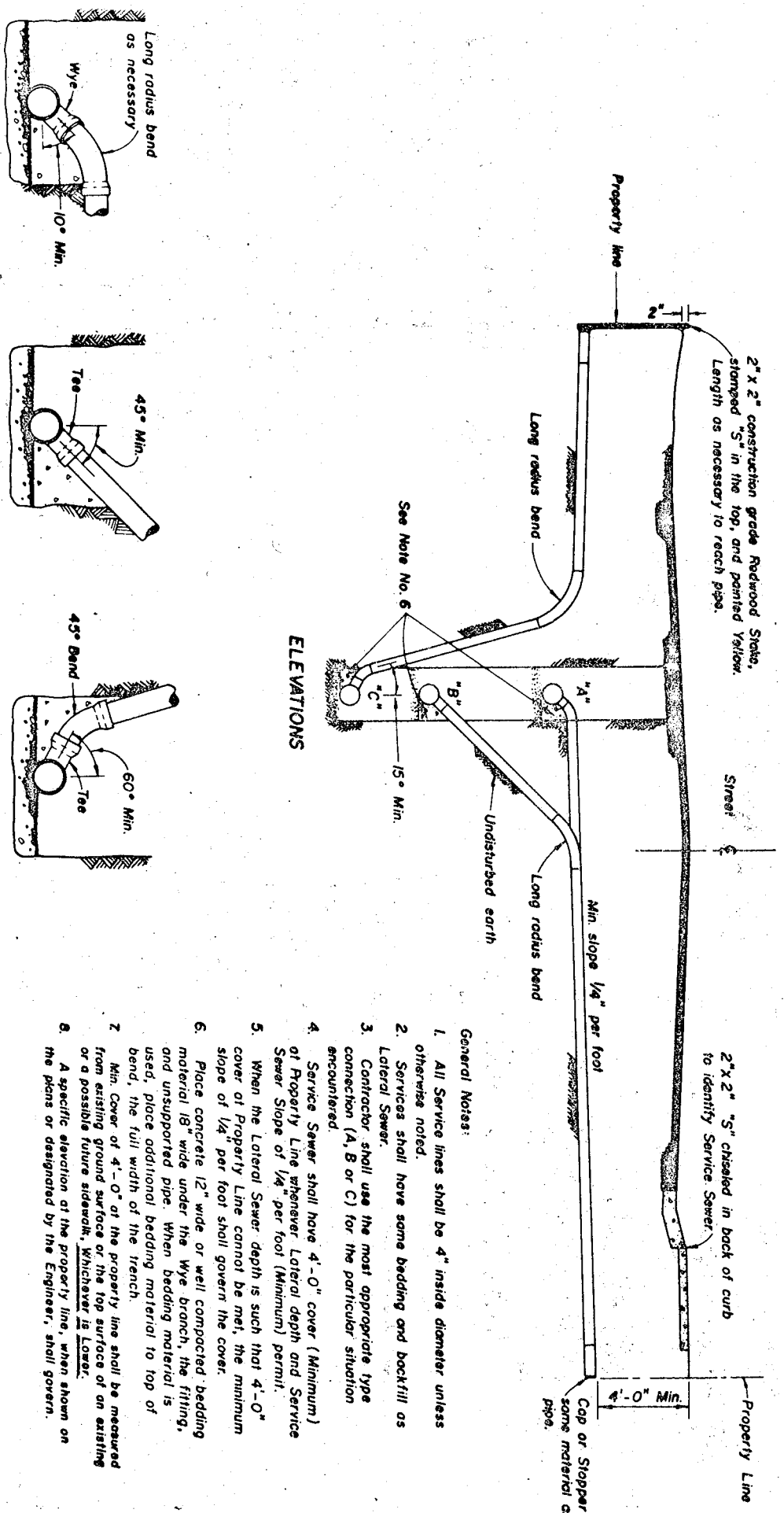

CONNECTION DETAILS

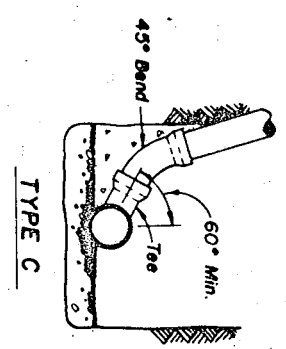
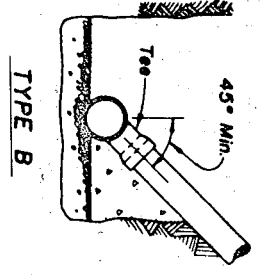
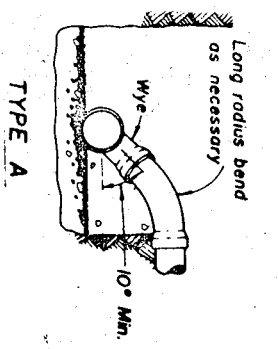

ELEVATIONS

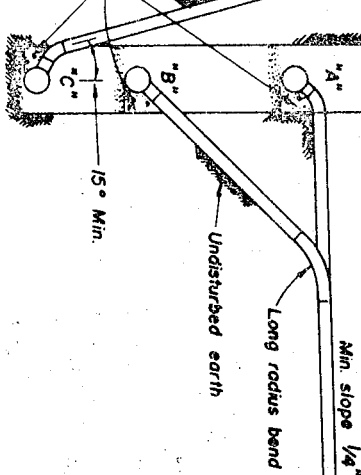

General Notes:

1. All Service lines shall be 4" inside diameter unless otherwise noted.
2. Services shall have some bedding and backfill as Lateral Sewer.
3. Contractor shall use the most appropriate type connection (A, B or C) for the particular situation encountered.
4. Service Sewer shall have 4'-0" cover (Minimum) of Property Line whenever Lateral depth and Service Sewer Slope of 1/4" per foot (Minimum) permit.
5. When the Lateral Sewer depth is such that 4'-0" cover of Property Line cannot be met, the minimum slope of 1/4" per foot shall govern the cover.
6. Place concrete 12" wide or well compacted bedding material 18" wide under the Wye branch, the fitting, and unsupported pipe. When bedding material is used, place additional bedding material to top of bend, the full width of the trench.
7. Min. Cover of 4'-0" at the property line shall be measured from existing ground surface or the top surface of an existing or a possible future sidewalk, whichever is lower.
8. A specific elevation at the property line, when shown on the plans or designated by the Engineer, shall govern.

SACRAMENTO COUNTY  
DEPARTMENT OF PUBLIC WORKS  
UTILITIES DIVISION

SERVICE SEWERS

RECOMMENDED  
CHIEF, UTILITIES DIVISION  
*W. H. ...*  
APPROVED  
DIRECTOR OF PUBLIC WORKS  
*A. L. ...*

NO SCALE  
DATE MARCH, 1955  
DRAWN BY K L G  
9/10-S-5

FIXTURE UNITS * G.P.M.	A	B	D	L <sub>1</sub>	L <sub>2</sub>
0-9 (0-67 G.P.M.)	6"	24	30	36	24
10-15 (67-112 G.P.M.)	9"	30	30	48	30
16-22 (112-165 G.P.M.)	12"	36	36	60	36
OVER 22	See Note 2				

\* Total rated discharge capacity of all fixtures, equipment or appliances discharging into interceptor in accordance with Chapter 4, Uniform Plumbing Code or actual known flow rate.

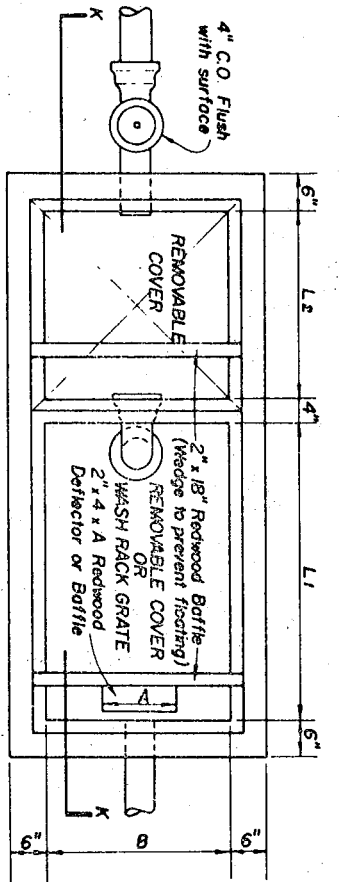

PLAN

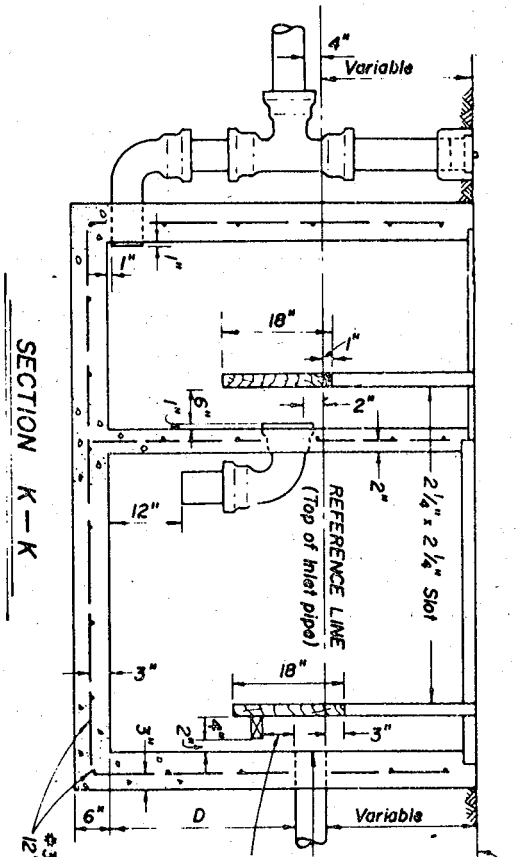

Ground or Floor Level

Note:  
All pipe and fittings within Waste Interceptor to be Cast Iron, B.A.B or B.A.S, short body and same size as inlet pipe.

3 R-Bars @ 12" O.C. both ways ALL WALLS

SECTION K-K

- General Notes:
1. Removable cover design shall be dictated by strength and location requirements as determined by the installer, but shall be of such a design to provide convenient access to each entire compartment for cleaning. The cover may be sectional, but the entire cover or any section thereof shall weigh no more than 100 lbs. The cover shall be of solid design, essentially waterproof, installed at ground or floor level and kept clear of all obstructions so as to be readily accessible for cleaning and inspection.
  2. The size of interceptor required for waste flows exceeding 22 fixture units (165 gpm.) shall be individually determined.
  3. Interceptors installed as oil separators shall have flow introduced through the inlet pipe as shown, not through the wash rack grate, etc.

RECOMMENDED

*William J. ...*  
CHIEF, UTILITIES DIVISION

APPROVED *A. R. ...*  
DIRECTOR OF PUBLIC WORKS

SACRAMENTO COUNTY  
DEPARTMENT OF PUBLIC WORKS  
UTILITIES DIVISION

**WASTE INTERCEPTOR**

NO SCALE  
DATE: MARCH, 1965  
DRAWN BY: K. L. G.

910-S-6

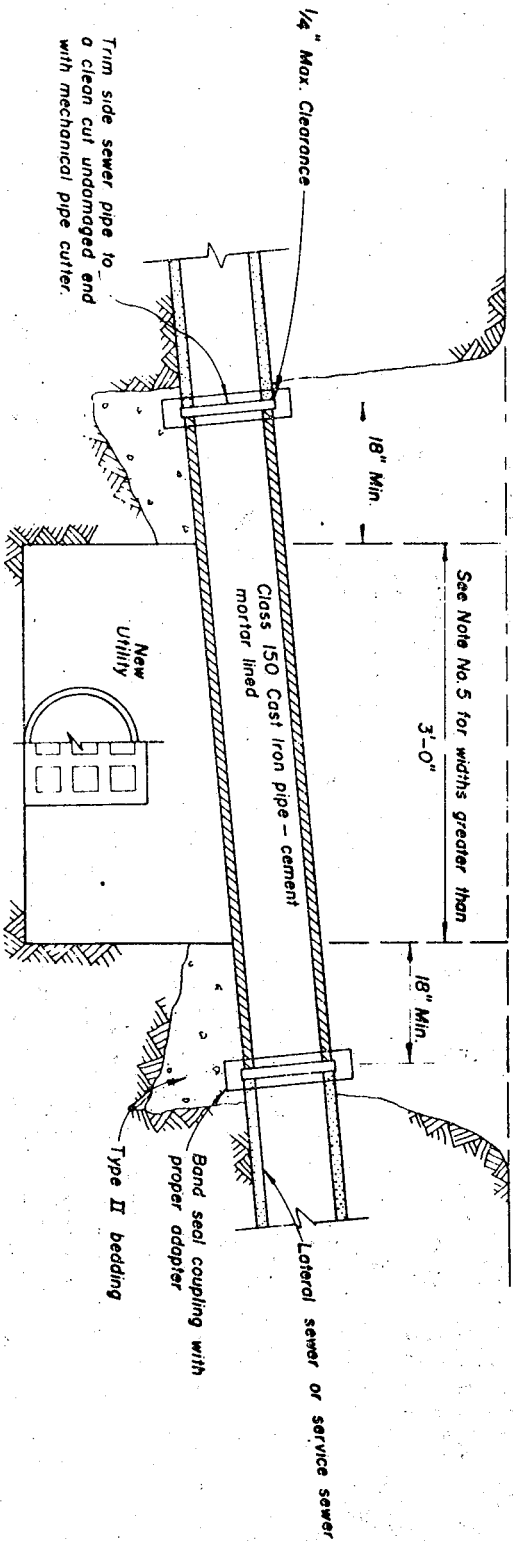

- Notes
1. Inside diameter of Cast Iron pipe to be the same as the pipe to which it connects.
  2. Cast Iron pipe is to be used as per this detail whenever the lateral or service sewer is cut or damaged.
  3. Cast Iron pipe is to be used as per this detail whenever construction passes beneath the lateral or service sewer.
  4. Alteration of sewer grades will be permitted only after written permission has been received from Sacramento County Utilities Division.
  5. Whenever the span, whether caused by trench width, or crossing angle, of the Cast Iron pipe exceeds 3'-0" replacement procedure and material shall be as directed by Sacramento County Utilities Division.

RECOMMENDED

CHIEF, UTILITIES DIVISION

*W. M. ...*

APPROVED

DIRECTOR OF PUBLIC WORKS

*A. E. ...*

SACRAMENTO COUNTY  
DEPARTMENT OF PUBLIC WORKS  
UTILITIES DIVISION

UTILITY CROSSING

NO SCALE  
DATE: MARCH, 1965  
DRAWN BY: K. L. G.

910-S-7

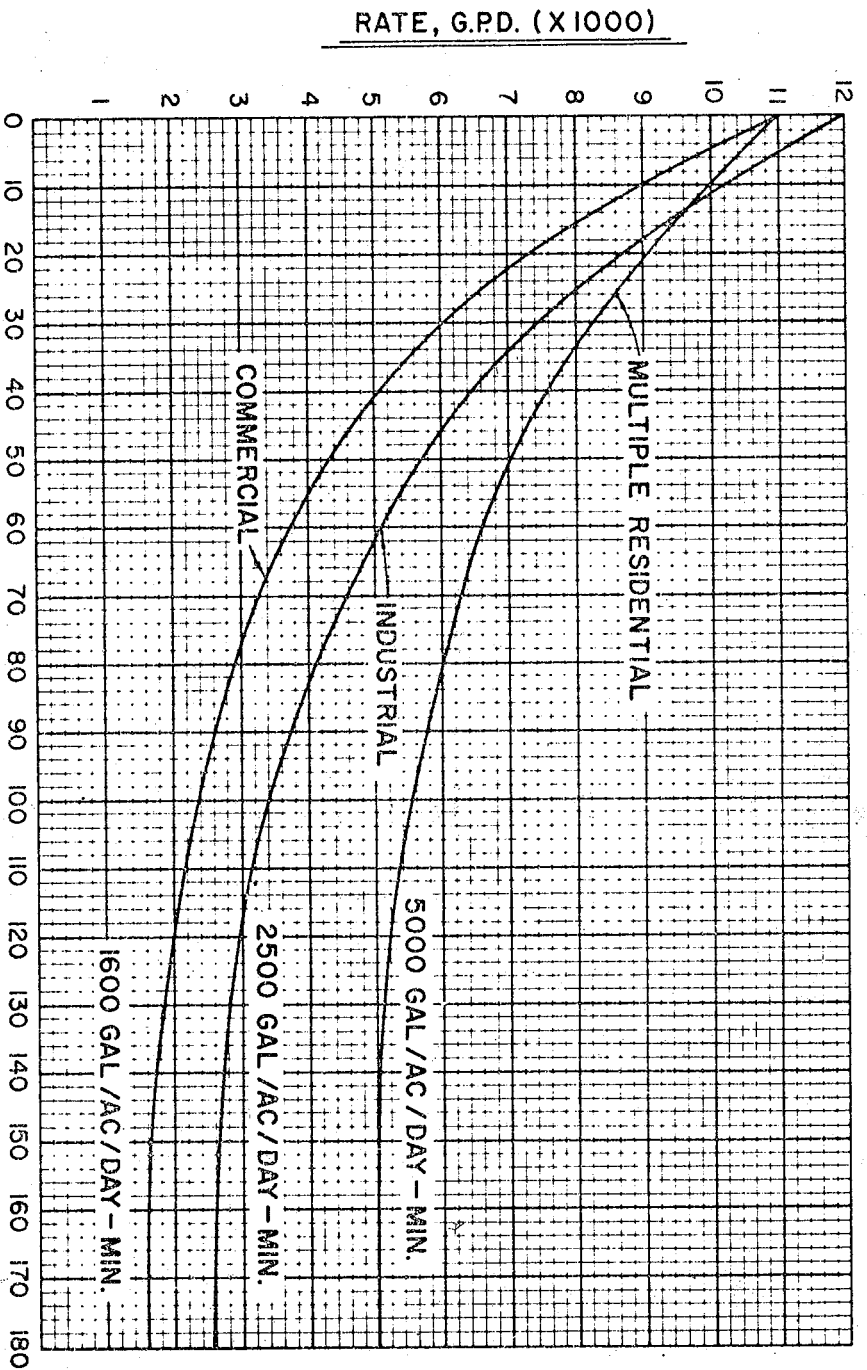

CONTRIBUTING AREA, ACRES

RECOMMENDED: *[Signature]*  
 CHIEF, UTILITIES DIVISION

APPROVED: *[Signature]*  
 DIRECTOR OF PUBLIC WORKS

SACRAMENTO COUNTY DEPARTMENT OF PUBLIC WORKS UTILITIES DIVISION	
ESTIMATED AVERAGE FLOW, COMMERCIAL, INDUSTRIAL, AND MULTIPLE RESIDENTIAL ZONED AREAS	
NO SCALE DATE: MARCH, 1966 DRAWN BY: K. L. G.	910 - S - 8

**PEAKING FACTOR**

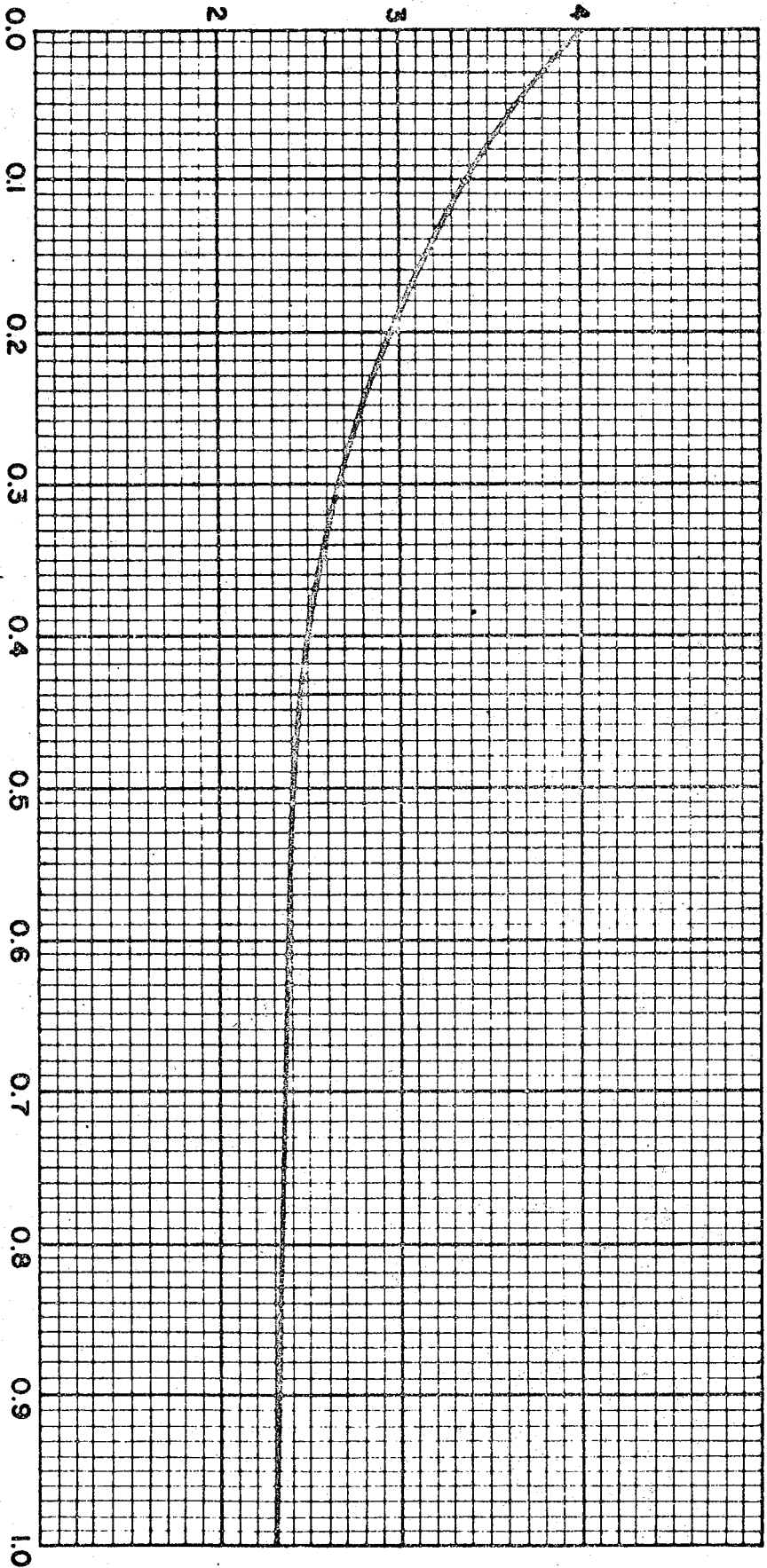

**AVERAGE FLOW, M.G.D.**

SACRAMENTO COUNTY  
DEPARTMENT OF PUBLIC WORKS  
UTILITIES DIVISION

**PEAKING FACTORS**

RECOMMENDED: *[Signature]*  
CHIEF, UTILITIES DIVISION

APPROVED: *[Signature]*  
DIRECTOR OF PUBLIC WORKS

NO SCALE  
DATE: MARCH, 1966  
DRAWN BY: K.L.G.

910 - S - 9

PIPE SIZE, INCHES	COVER, FEET	BEDDING - BACKFILL TYPE	MAX. TRENCH WIDTH, INCHES
6	14.0 OR LESS	NO DESIGNATION NEEDED	NO MAX. 28
	14.1 - 18.5	TYPE II	
	18.6 - 35	TYPE II	
8	11.5 OR LESS	NO DESIGNATION NEEDED	27 NO MAX. 29
	11.6 - 14.0	TYPE I	
	14.1 - 15.5	TYPE II	
	15.6 - 25	TYPE II	
10	10.5 OR LESS	NO DESIGNATION NEEDED	29 NO MAX. 27 32 31 29
	10.6 - 14.0	TYPE I	
		TYPE II	
	14.1 - 19	TYPE I	
		TYPE II	
	19.1 - 24	TYPE II	
12	10.5 OR LESS	NO DESIGNATION NEEDED	32 NO MAX. 28 34 27 32
	10.6 - 14.0	TYPE I	
		TYPE II	
	14.1 - 23	TYPE I	
		TYPE II	
	23.1 - 35	TYPE I	
		TYPE II	

SACRAMENTO COUNTY  
DEPARTMENT OF PUBLIC WORKS  
UTILITIES DIVISION

BEDDING vs MAXIMUM TRENCH WIDTH

(V.C.P. ONLY)

RECOMMENDED: *W. W. Wampler Jr.*  
CHIEF, UTILITIES DIVISION

APPROVED: *A. R. Kiebler*  
DIRECTOR OF PUBLIC WORKS

NO SCALE  
DATE: MARCH, 1966  
DRAWN BY: K. L. G

910 - S - 10

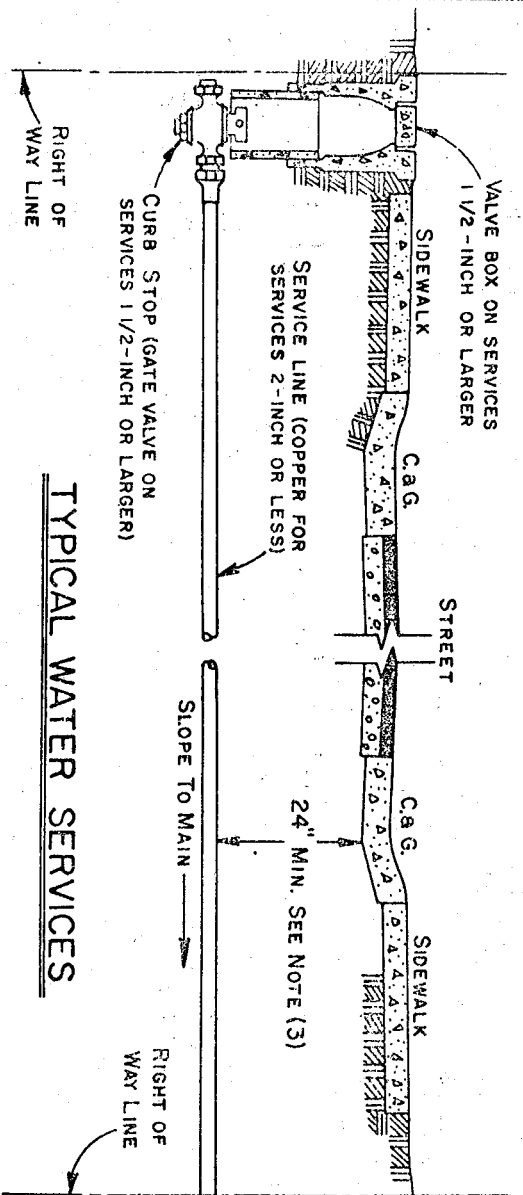

**TYPICAL WATER SERVICES**

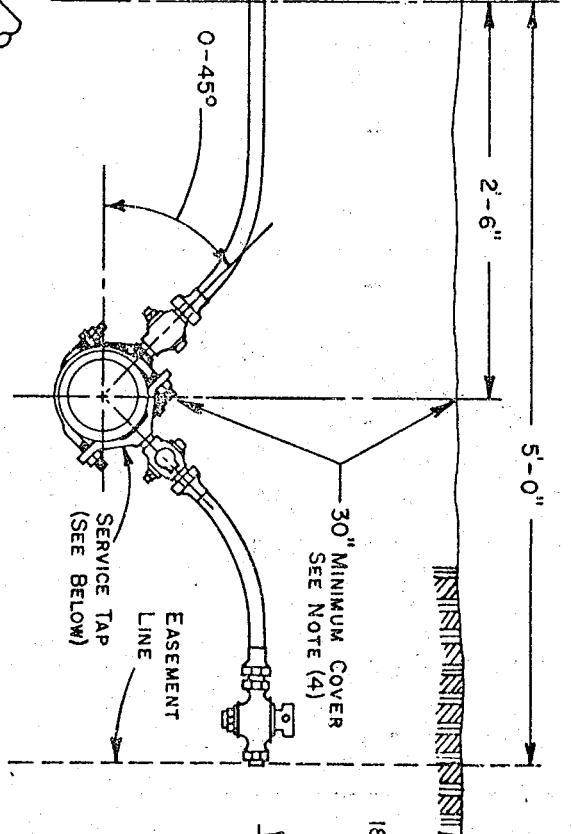

NOTES: (1) CORPORATION STOP, CURB STOP (OR GATE VALVE), AND SERVICE LINE TO BE SAME SIZE.

- (2) SERVICE CLAMPS SHALL BE SINGLE STRAP FOR UP TO 1" SERVICES, DOUBLE STRAP FOR LARGER SIZES, EXCEPT WHERE SIZE OF TAP EXCEEDS MANUFACTURERS' RECOMMENDED LIMIT FOR SIZE OF MAIN. FOR THIS SITUATION, A SPECIAL FITTING WILL BE SPECIFIED.
- (3) INCREASE MIN. CLEARANCE OF WATER SERVICE UNDER C&G TO 30" WHERE SERVICE LINE CROSSES SELECT SYSTEM ROADWAY, WHICH WILL BE SO SPECIFIED.
- (4) INCREASE MIN. COVER OF MAIN TO 36" WHERE INSTALLED IN SELECT SYSTEM ROADWAY, WHICH WILL BE SO SPECIFIED.

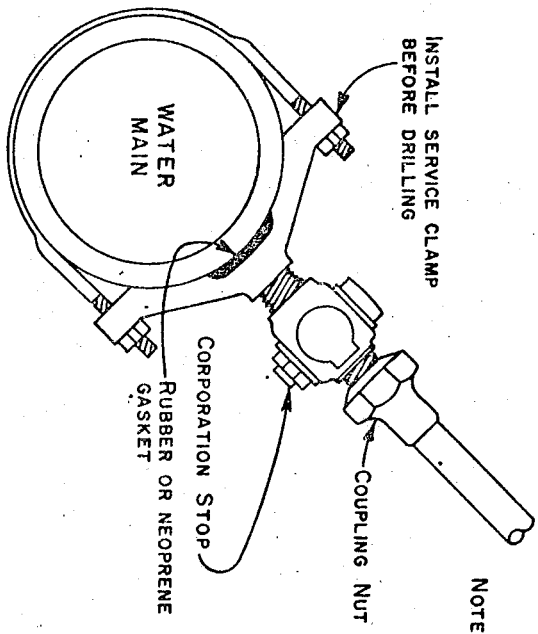
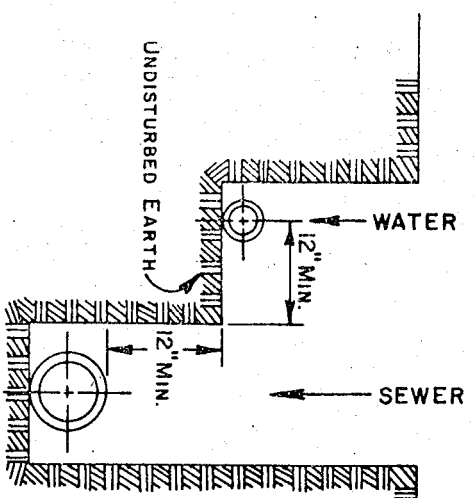

**(OPTIONAL)  
COMMON TRENCH FOR  
SEWER & WATER SERVICES**

**SERVICE TAP**

SACRAMENTO COUNTY  
DEPARTMENT OF PUBLIC WORKS  
UTILITIES DIVISION  
  
WATER SUPPLY STANDARDS  
WATER SERVICE INSTALLATION

RECOMMENDED: *William J. ...*  
CHIEF, UTILITIES DIVISION  
  
APPROVED: *A. R. ...*  
DIRECTOR OF PUBLIC WORKS

NO SCALE  
DATE: MARCH, 1965  
DRAWN BY: R.D.T.



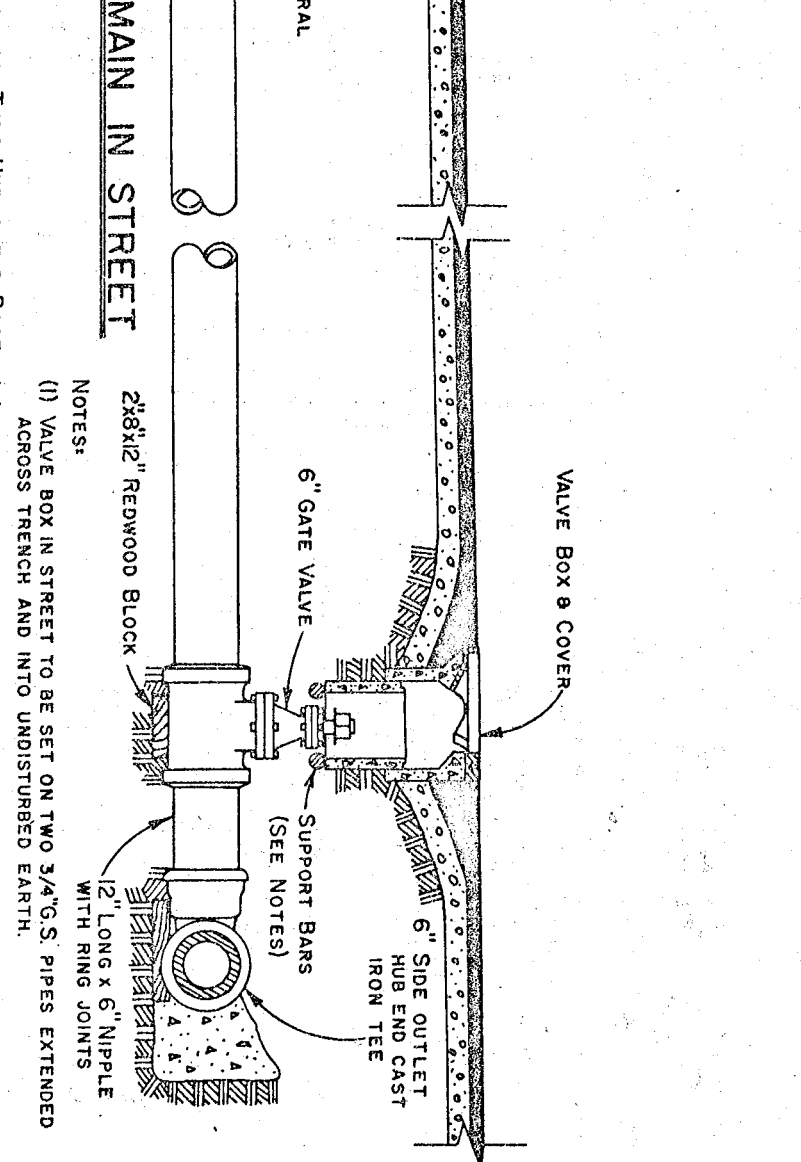
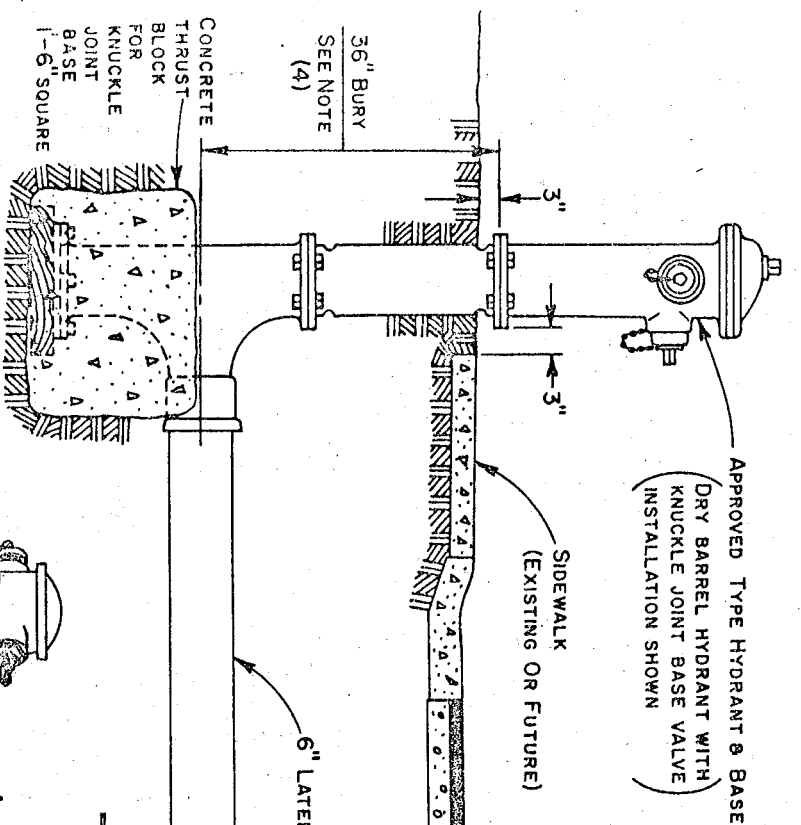

**MAIN IN STREET**

2x8x12" REDWOOD BLOCK

12" LONG x 6" NIPPLE WITH RING JOINTS

APPROVED TYPE HYDRANT & BASE  
(WET BARREL HYDRANT WITH ELBOW BASE INSTALLATION SHOWN FOR REFERENCE)

- NOTES:
- (1) VALVE BOX IN STREET TO BE SET ON TWO 3/4" G.S. PIPES EXTENDED ACROSS TRENCH AND INTO UNDISTURBED EARTH.
  - (2) DETAILS SHOWN FOR VALVES ON HYDRANT LATERALS SHALL APPLY TO VALVES ON MAINS.
  - (3) LIST OF APPROVED MATERIALS MAY BE OBTAINED FROM UTILITIES DIVISION (TYPES SHOWN ARE FOR ILLUSTRATION ONLY).
  - (4) BURY LENGTH TO BE 42" WHERE LATERAL TO HYDRANT IS INSTALLED IN SELECT SYSTEM ROADWAY, WHICH WILL BE SO SPECIFIED.

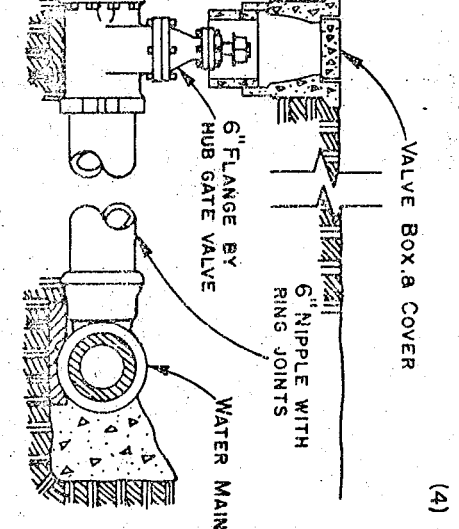
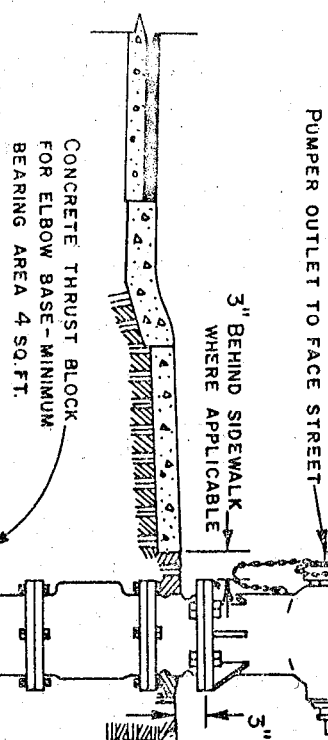

**MAIN IN EASEMENT**

RECOMMENDED  
CHIEF, UTILITIES DIVISION

APPROVED: *A. S. [Signature]*  
DIRECTOR OF PUBLIC WORKS

SACRAMENTO COUNTY  
DEPARTMENT OF PUBLIC WORKS  
UTILITIES DIVISION

WATER SUPPLY STANDARDS  
TYPICAL VALVE INSTALLATION  
AND  
FIRE HYDRANT INSTALLATION

NO SCALE  
DATE: MARCH, 1965  
DRAWN BY: R.D.T.

# REQUIRED BEARING AREA — TOTAL SQUARE FEET

TYPE OF FITTINGS	TYPICAL INSTALLATION						
	90° BEND	45° BEND	11 1/4° OR 22 1/2° BEND	TEE OR DEAD END	TEE w/PLUG	CROSS w/PLUG	CROSS w/PLUGS
4"	2	1	1	2	2	2	2
6"	4	2	1	3	4	4	4
8"	7	4	2	5	7	7	7
10"	12	6	3	8	12	12	12
12"	16	10	5	12	16	16	16

**NOTES:** (1) THRUST BLOCKS TO BE CONSTRUCTED OF CLASS "B" CONCRETE.

(2) AREAS GIVEN ARE FOR CLASS 150 PIPE AT TEST PRESSURE OF 150 P.S.I. IN SOIL WITH 2,000 P.S.F. BEARING CAPACITY.

INSTALLATIONS USING DIFFERENT PIPE, TEST PRESSURES, AND/OR SOIL TYPES SHOULD ADJUST AREAS ACCORDINGLY, SUBJECT TO APPROVAL OF ENGINEER.

(3) BLOCKS TO BE POURED AGAINST UNDISTURBED SOIL.

(4) JOINTS AND FACE OF PLUGS TO BE KEPT CLEAR OF CONCRETE.

SACRAMENTO COUNTY  
DEPARTMENT OF PUBLIC WORKS  
UTILITIES DIVISION

WATER SUPPLY STANDARDS  
THRUST BLOCK BEARING AREA

RECOMMENDED: *[Signature]* APPROVED: *[Signature]*  
CHIEF, UTILITIES DIVISION      DIRECTOR OF PUBLIC WORKS

NO SCALE  
DATE: FEBRUARY, 1965  
DRAWN BY: R.D.T.      913 - W - 3

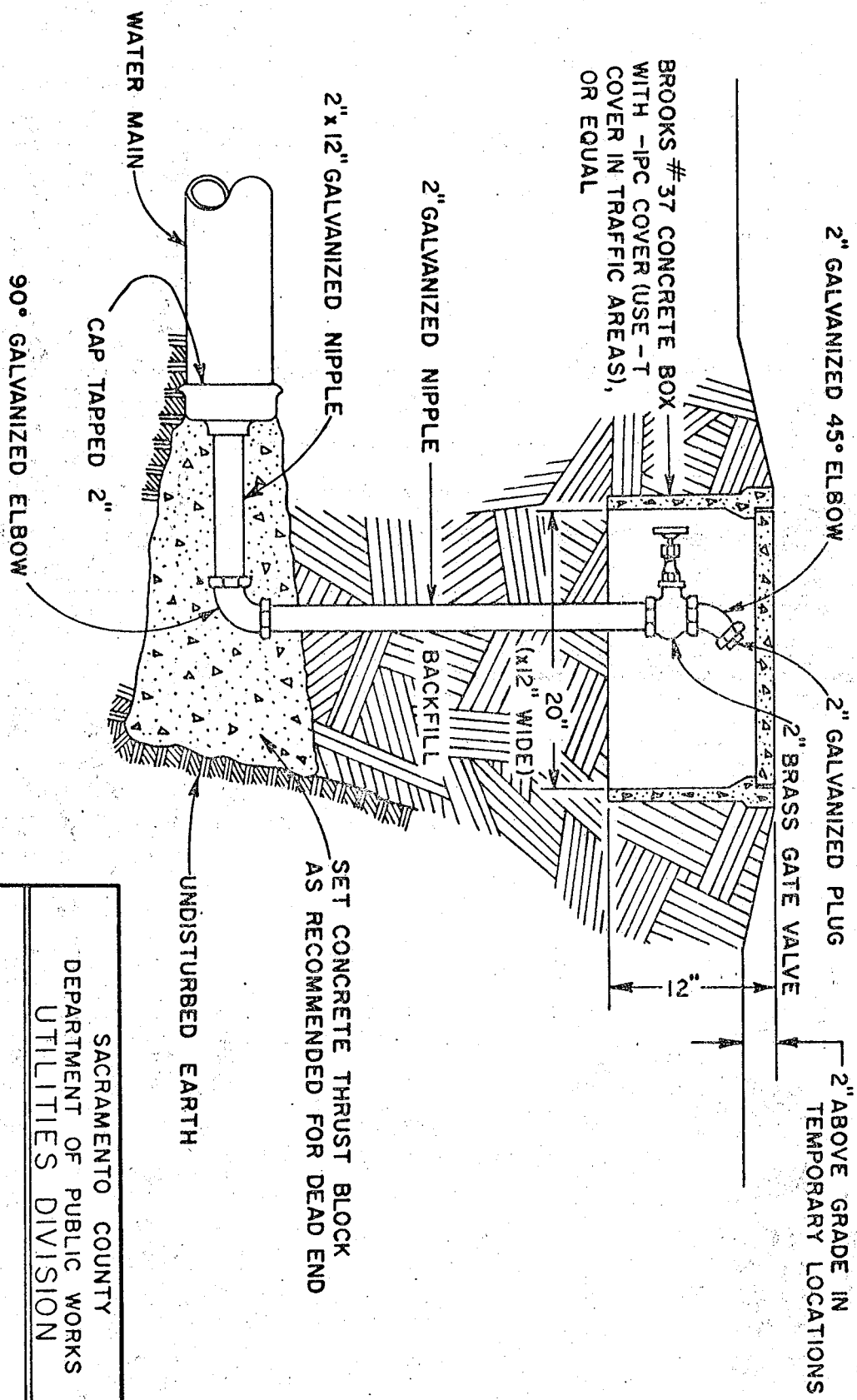

**ELEVATION**

RECOMMENDED: *W. L. ...*  
 CHIEF, UTILITIES DIVISION

APPROVED: *R. S. ...*  
 DIRECTOR OF PUBLIC WORKS

SACRAMENTO COUNTY DEPARTMENT OF PUBLIC WORKS UTILITIES DIVISION	
WATER SUPPLY STANDARDS 2" BLOWOFF VALVE	
NO SCALE DATE: FEBRUARY, 1965 DRAWN BY: R.D.T.	913 - W - 4

# REQUIRED BEARING AREA — TOTAL SQUARE FEET

TYPE OF FITTINGS	90° BEND		45° BEND		11 1/4° OR 22 1/2° BEND		TEE OR DEAD END		TEE w/PLUG		CROSS w/PLUG		CROSS w/PLUGS									
	TYPICAL INSTALLATION																					
SIZE OF PIPE	4"	6"	8"	10"	12"	4"	6"	8"	10"	12"	4"	6"	8"	10"	12"							
	2	4	7	10	16	1	2	4	6	10	1	1	2	3	5	2	2	2	4	4	4	

**NOTES:** (1) THRUST BLOCKS TO BE CONSTRUCTED OF CLASS "B" CONCRETE.

(2) AREAS GIVEN ARE FOR CLASS 150 PIPE AT TEST PRESSURE OF 150 P.S.I. IN SOIL WITH 2,000 P.S.F. BEARING CAPACITY.

INSTALLATIONS USING DIFFERENT PIPE, TEST PRESSURES, AND/OR SOIL TYPES SHOULD ADJUST AREAS ACCORDINGLY, SUBJECT TO APPROVAL OF ENGINEER.

(3) BLOCKS TO BE POURED AGAINST UNDISTURBED SOIL.

(4) JOINTS AND FACE OF PLUGS TO BE KEPT CLEAR OF CONCRETE.

SACRAMENTO COUNTY  
DEPARTMENT OF PUBLIC WORKS  
UTILITIES DIVISION

WATER SUPPLY STANDARDS  
THRUST BLOCK BEARING AREA

RECOMMENDED: *[Signature]* CHIEF, UTILITIES DIVISION \* APPROVED: *[Signature]* DIRECTOR OF PUBLIC WORKS

NO SCALE  
DATE: FEBRUARY, 1965  
DRAWN BY: R.D.T. 913 - W - 3

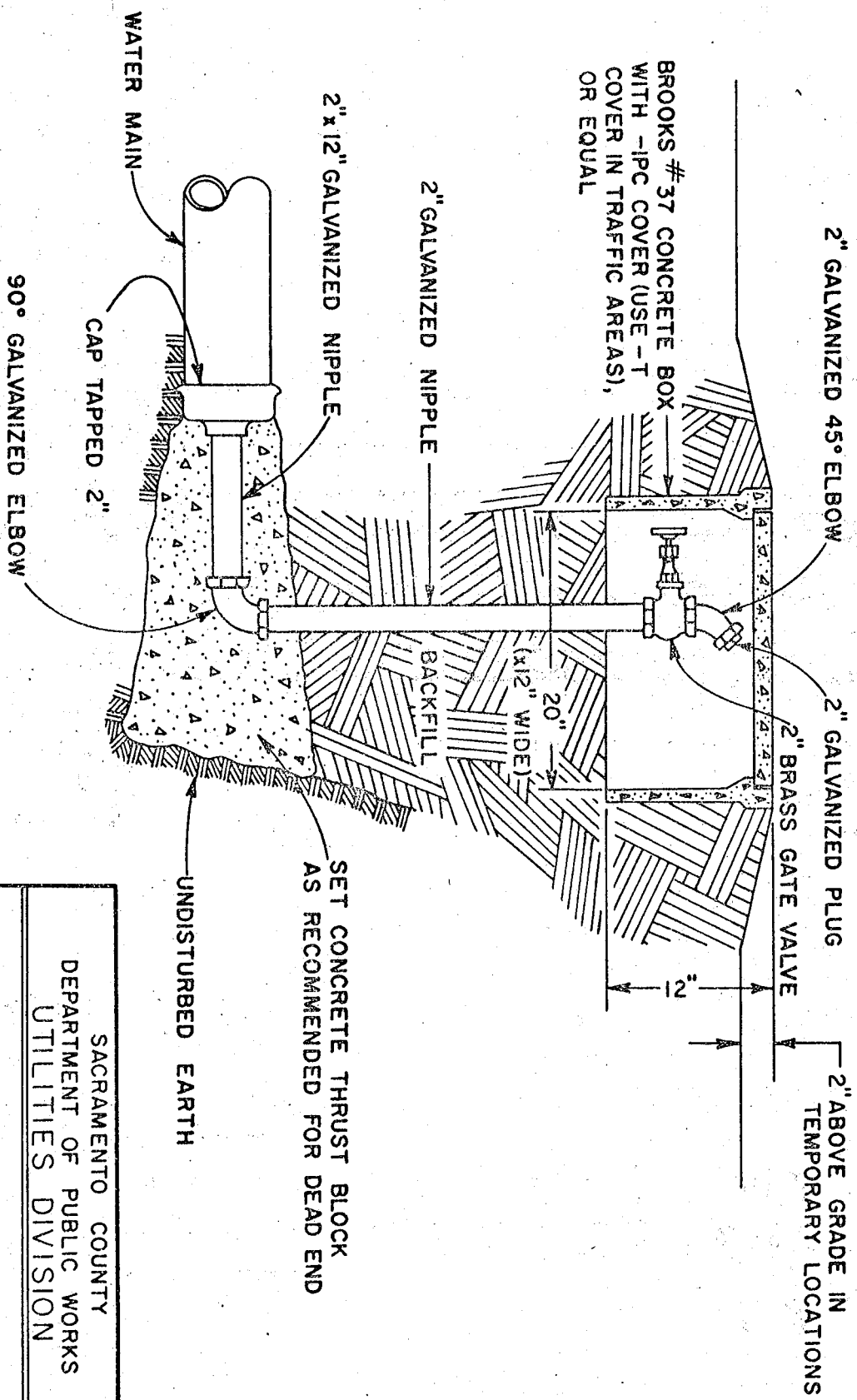

BROOKS #37 CONCRETE BOX WITH -IPC COVER (USE -T COVER IN TRAFFIC AREAS), OR EQUAL

2" GALVANIZED 45° ELBOW

2" GALVANIZED PLUG

2" BRASS GATE VALVE

2" ABOVE GRADE IN TEMPORARY LOCATIONS

2" GALVANIZED NIPPLE

2" x 12" GALVANIZED NIPPLE

90° GALVANIZED ELBOW

WATER MAIN

CAP TAPPED 2"

BACKFILL

(x12" WIDE)

20"

SET CONCRETE THRUST BLOCK AS RECOMMENDED FOR DEAD END

UNDISTURBED EARTH

**ELEVATION**

RECOMMENDED: *W. H. ...*  
CHIEF, UTILITIES DIVISION

APPROVED: *R. S. ...*  
DIRECTOR OF PUBLIC WORKS

SACRAMENTO COUNTY DEPARTMENT OF PUBLIC WORKS UTILITIES DIVISION	
WATER SUPPLY STANDARDS	
2" BLOWOFF VALVE	
NO SCALE DATE: FEBRUARY, 1965 DRAWN BY: R.D.T.	913 - W - 4

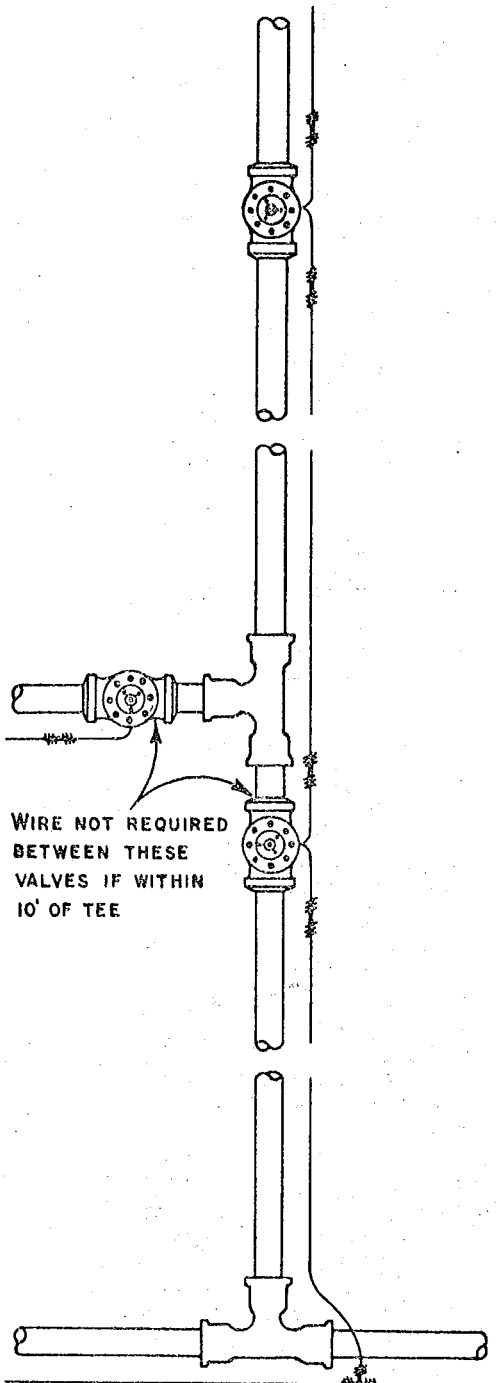

WIRE NOT REQUIRED BETWEEN THESE VALVES IF WITHIN 10' OF TEE

SPLICE RUNS TOGETHER KEEP CLEAR OF FITTING

TYPICAL LAYOUT

NOTES:

- (1) WIRE TO BE CONTINUOUS BETWEEN VALVE BOXES, EXCEPT AS NOTED.
- (2) BARE WIRE NOT TO TOUCH VALVES OR FITTINGS.
- (3) LOCATING WIRE TO BE LAID AT BOTTOM OF TRENCH, NEXT TO PIPE.

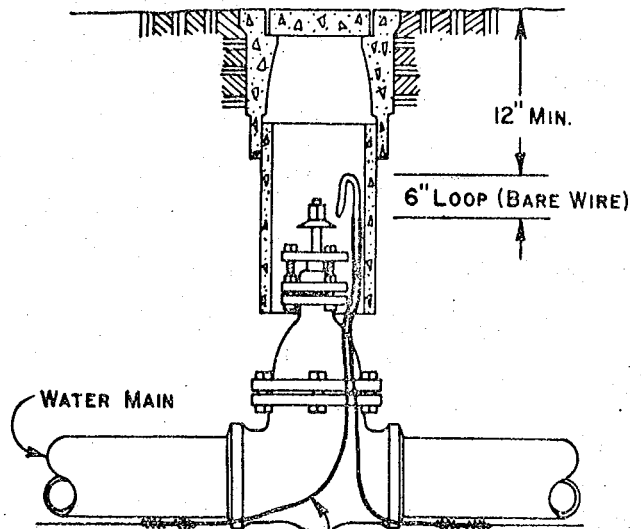

#10 AWG, SINGLE STRAND, SOFT DRAWN COPPER WIRE; BARE ALONG PIPE, TYPE TW 3/64" INSULATION INTO VALVE BOX.

SEE DETAIL BELOW

VALVE DETAIL



INSULATION INTO VALVE BOX (REMOVE AT SPLICE)

BARE WIRE ALONG PIPE

SPLICE DETAIL

RECOMMENDED:

*W. H. ...*  
CHIEF, UTILITIES DIVISION

APPROVED:

*A. E. ...*  
DIRECTOR OF PUBLIC WORKS

SACRAMENTO COUNTY  
DEPARTMENT OF PUBLIC WORKS  
UTILITIES DIVISION

WATER SUPPLY STANDARDS  
LOCATING WIRE FOR  
NON-METALLIC WATER PIPES

NO SCALE  
DATE: FEBRUARY, 1965  
DRAWN BY: R.D.T.

SP - W - 5